

TECHNICAL MANUAL

FIELD AND SUSTAINMENT MAINTENANCE MANUAL
(INCLUDES REPAIR PARTS AND SPECIAL TOOLS LIST)

FOR

**SEMITRAILER, TACTICAL, BREAKBULK/CONTAINER
TRANSPORTER, 22-1/2 TON, RESET
M871R (NSN 2330-01-528-6690) (EIC: CAN)
M871A1R (NSN 2330-01-528-6673) (EIC: CAM)
M871A2R (NSN 2330-01-528-6698) (EIC: CAK)**



DISTRIBUTION STATEMENT A - Approved for public release; distribution is unlimited.

HEADQUARTERS, DEPARTMENT OF THE ARMY

SEPTEMBER 2008

WARNING SUMMARY

This warning summary contains general safety warnings and hazardous materials warnings that must be understood and applied during operation and maintenance of the semitrailer. Failure to follow these warnings may result in serious injury or death to personnel.

WARNING

AIR BRAKE CHAMBERS

- To prevent injury, keep hands away from brake chamber push rods and slack adjusters. They will move as service brakes are operated, and will automatically apply if system pressure drops. Fingers/hands could be pinched or cut by moving parts. Failure to comply may result in injury to personnel.
- Disassembly of air brake chambers is NOT authorized. When inspecting or caging air brake chambers, do not position yourself in front of, or in line with, the chamber. Failure to follow this warning may result in injury or death to personnel.
- Discarded air brake chambers must be safely and properly disposed of. They should be disarmed prior to disposal. Failure to disarm assembly prior to disposal may, in time, result in spontaneous release of the spring chamber and its contents, causing death, personal injury, and/or property damage.

WARNING

BRAKE SYSTEM

- Before performing any work on the spring brake system, chock the wheels front and rear to prevent semitrailer movement. Failure to follow this warning may result in injury or death to personnel.
- All brake chambers must be caged before working on the brake system to prevent serious injury to personnel and damage to equipment.
- The axle must be firmly supported to prevent shifting of the semitrailer. Shifting may cause serious injury to personnel and damage to equipment.
- A hot brake can cause serious burns. Exercise extreme caution before attempting to touch brake drum after use. Radiated heat will be felt before drum is touched. Failure to comply may result in injury to personnel.
- Do not use air pressure or a steel bristle brush to clean cones and rollers. Use kerosene or diesel fuel to clean bearings. Do not use gasoline. Do not rotate bearings using compressed air, as this will damage the polished surfaces. Bearing failure can cause injury to personnel.
- At triennial brake inspection/service all brake wheel end components must be cleaned and inspected for wear/damage. Inspect all linings, springs, pins, rollers, clips, and bushings on each axle end. Make sure seals show no signs of leakage on axle, spider, or wheels. Use all components of replacement kits and balance repairs on both axle ends. Failure to comply can cause injury to personnel and damage to equipment.
- Do not allow brake lining to wear to the point that the rivets touch the drum. This condition can cause brake failure, injury to personnel, and damage to equipment.
- The triennial check/service is based on normal operation. Conditions identified such as hot/cold brake drums, leakage/seepage of spindle/hub grease, brake lock-up, wheel end noise/damage, and impact damage will require inspection and repair to be performed when the incident occurs, not at service interval. Failure to comply can cause injury to personnel and damage to equipment.
- Clean and check all S-camshaft brake components for wear and damage. Replace worn or damaged parts. At triennial service replace all O-rings, bushings, retainers, snap rings, lockwashers, and brackets on each axle end. Failure to comply could cause injury to personnel and damage to equipment.

WARNING

BRAKE SYSTEM - CONTINUED

- Clean and check service brakes and all brake components for wear and damage. Replace worn or damaged parts. At triennial service replace all springs, pins, rollers, clips, and bushings on each axle end. Failure to comply may cause injury to personnel and damage to the equipment.
- Jack must be positioned directly under axle to prevent slippage. Direct all personnel to stay clear of semitrailer when semitrailer is supported in the air. Failure to comply may result in injury or death to personnel or damage to equipment.
- To prevent shifting of semitrailer, floor jack should be used only on a hard, level surface. Use ground boards, if necessary. Chock tires. Failure to comply may result in injury or death to personnel.
- Wipe excess lubricant from area of brake shoe linings to prevent any contamination of linings. Replace linings that have been contaminated with lubricant. Failure to follow this warning may cause brakes to malfunction, resulting in serious injury or death to personnel.
- Do not use any grease with Teflon, over 3% molysulfide content, or “white” grease in the automatic slack adjusters. These lubricants will adversely affect the friction clutch and cause it not to hold the adjustment, resulting in premature failure, injury to personnel, and damage to equipment.

WARNING

BULKHEAD REPLACEMENT

Bulkhead weighs 557 lb (253 kg). Use suitable lifting device and two personnel to replace bulkhead. Failure to comply may result in injury or death to personnel.

WARNING

COMPRESSED AIR

Particles blown by compressed air are hazardous. DO NOT exceed 15 psi (103 kPa) nozzle pressure when drying parts with compressed air. Use a maximum of 30 psi (207 kPa) when cleaning components. DO NOT direct compressed air against human skin. To prevent injury, user must wear protective goggles or face shield. Make sure air stream is directed away from user and other personnel in the area. Failure to follow this warning may result in injury to personnel.

WARNING

CORNER AND SIDE STAKES REPLACEMENT

Ensure retaining hardware is present and serviceable. Failure to comply may result in injury to personnel.

WARNING

ELECTRICAL POWER

- Disconnect electrical power source before performing any troubleshooting on wiring harness, connectors, or lights. Failure to comply could result in injury to personnel.
- Disconnect electrical power source before performing any cleaning on the electrical system. Failure to comply may result in injury to personnel.
- Disconnect electrical power source before performing any maintenance on the electrical system. Failure to comply may result in injury to personnel.

WARNING

GLADHANDS

Service air is identified by blue markings on gladhand; emergency air is identified by red markings on gladhand. Do not cross service/emergency air lines at gladhands. Make sure they are hooked up correctly to meet brake air pressure requirements. Failure to follow this warning may result in injury to personnel or damage to equipment.

WARNING

HUBS AND DRUMS REPLACEMENT

- Jack must be positioned directly under axle to prevent slippage. Direct all personnel to stay clear of semitrailer when semitrailer is supported in the air. Failure to comply may result in injury or death to personnel or damage to equipment.
- To prevent shifting of semitrailer, floor jack should be used only on a hard, level surface. Use ground boards, if necessary. Chock tires. Failure to comply may result in injury or death to personnel.
- Do not get oil on mounting face of drum or wheel. Failure to comply may result in injury or death to personnel.

WARNING

LANDING GEAR REPLACEMENT

Landing gear weighs 200 lb (91 kg). Use four personnel to replace landing gear. Failure to comply may result in injury or death to personnel.

WARNING

LANDING LEG SCISSORS

Ensure landing leg scissor assemblies retaining (hitch) pins are installed extending inward. If installed extending outward, they will be a contact hazard and may result in injury to personnel.

WARNING

LOADING/UNLOADING OPERATIONS

Do not place any part of your body under a container during the loading or unloading operation. Container may crush, pinch, or pin any body part that is under a container. Failure to comply may result in injury to personnel.

WARNING

SLINGING OPERATIONS

- Do not get under semitrailer while slinging operations are underway. Do not lift a loaded semitrailer. Failure to observe this warning could result in serious injury or death to personnel and damage to equipment.
- Do not lift the semitrailer without a ground guide, using a 30 ft (9 m) guideline attached to one rear lift point. Lack of ground guide steering assistance could result in serious injury or death to personnel and damage to equipment.

WARNING

SOLVENT CLEANING COMPOUND

Solvent cleaning compound MIL-PRF-680 Type III is an environmentally compliant and low toxic material. However, it may be irritating to the eyes and skin. Use protective gloves and goggles. Use in well-ventilated areas. Keep away from open flames and other sources of ignition. Failure to comply may result in injury or death to personnel.

WARNING

SPARE TIRE AND WHEEL ASSEMBLY

- Make sure spare tire and wheel assembly is secured in carrier and securing hardware is present. Failure to secure the spare tire may result in the spare tire falling off of trailer, causing injury or death to personnel.
- Spare tire and wheel assembly weighs 179 lb (81.2 kg). This requires two people to remove the spare from the carrier or install it on the carrier. Slide the spare from the carrier or onto the carrier. Refrain from lifting the spare into position. Failure to comply could result in injury to personnel.

WARNING

STOWAGE BOX REPLACEMENT

Stowage box weighs 195 lb (88 kg). Use suitable lifting device and two personnel to replace stowage box. Failure to comply may result in injury or death to personnel.

WARNING

SUSPENSION OPERATOR PMCS

Notify Organizational Maintenance at first month of new semitrailer operation or first 1,000 miles (1,609 km) (from HUBODOMETER®) that suspension nuts must be torqued. Reference Item No. 1 of Organizational PMCS. Failure to comply could cause loss of suspension/parts which could result in injury to personnel and damage to equipment.

WARNING

SUSPENSION REPLACEMENT

- Jack must be positioned directly under axle to prevent slippage. Direct all personnel to stay clear of semitrailer when supported in the air. Failure to comply could result in injury or death to personnel or damage to equipment.
- To prevent shifting of semitrailer, floor jack should be used only on a hard, level surface. Use ground boards, if necessary. Chock tires. Failure to comply could result in injury or death to personnel.
- The trunnion must be firmly supported with jack stands or floor jacks prior to performing steps 3 and 4. Failure to comply could result in injury to personnel and damage to equipment.
- The trunnion tube weighs 100 lb (45.4 kg) and requires two persons to lift. Failure to comply could result in injury to personnel.
- The axles must be firmly supported with jack stands or floor jacks prior to performing steps 6 thru 10. Failure to comply may result in injury to personnel.
- Axles weigh 200 lb (90.7 kg) and require four persons to lift. Failure to comply could result in injury to personnel.

WARNING

TIRE AND WHEEL ASSEMBLY

- Floor jack, if used, must be positioned directly under axle to prevent slippage. Floor jack must be used only on a hard, level surface to prevent shifting of semitrailer. Direct all personnel to stay clear of semitrailer when supported in the air. Failure to comply may result in injury or death to personnel or damage to equipment.
- Tire and wheel assembly weighs 179 lb (81 kg). Use two personnel to handle tire and wheel assembly. Failure to comply may result in injury to personnel.
- For service and repair tasks on the semitrailer, the ground boards and tire chocks should be used to ensure safe coupling and prevent semitrailer movement. Failure to comply may result in injury or death to personnel.
- If nuts cannot be torqued, at first opportunity have Organizational Maintenance torque nuts to proper specifications. If mission allows, stop and check nuts for tightness. Failure to comply may result in injury to personnel or damage to equipment.

WARNING

TOWING

- Do not tow the semitrailer with the M52, M52A1, or M52A2 truck tractor. The M52 series inherent design capabilities are not compatible with the semitrailer, and use would result in a serious compromise to the safety of personnel and equipment.
- Be sure all personnel stand clear of the towing vehicle and semitrailer during coupling operations. Failure to comply may result in injury or death to personnel.
- Do not tow the semitrailer with an unsecured cargo container. Accident may occur resulting in injury or death to personnel.
- When transporting the 8-1/2 ft commercial container, the towing vehicle fifth wheel height must not exceed 50.4 in. (1.28 m) to comply with the 157.48 in. (4 m) overall height limit for USAREUR. The M915 fifth wheel height meets this requirement. Failure to follow this warning may result in injury to personnel or damage to equipment.
- When towing the semitrailer with M818, M931 series, or M932 series tractors, the fifth wheel wedges must be in the locked-in (pushed-in) mode for highway and secondary road use, and in the locked-out (pulled-out) mode for cross-country operation.
- Extreme caution must be exercised in all turns, curves, and highway cloverleaves when towing a high center of gravity containerized load as containerized load may fall off of trailer.
- Under no circumstances shall speeds exceed the following:

Highway	55 mph (89 kph)
Secondary	35 mph (56 kph)
Trails	15 mph (24 kph)
Rough	10 mph (16 kph)

- Failure to observe these warnings may result in injury to personnel or damage to equipment.

WARNING

WORK SAFETY

- Lifting cables, chains, hooks, and slings used for lifting components must be in good condition and of suitable capacity. Failure to follow this warning may cause injury or death to personnel and damage to equipment.
- Improper use of lifting equipment and improper attachment of cables to components may cause injury to personnel and damage to equipment.
- Use extreme caution when handling heavy parts. Provide adequate support and use assistance during procedure. Ensure that any lifting device used is in good condition and of suitable load capacity. Keep clear of heavy parts supported only by lifting device. Failure to follow this warning may cause injury or death to personnel.
- For service and repair tasks on the semitrailer, the ground boards and tire chocks should be used to ensure safe coupling and prevent semitrailer movement. Failure to comply may result in injury or death to personnel.
- Watch hands and fingers when removing/installing ground boards. Hands/fingers could be pinched or cut if not careful when removing/installing ground boards.
- Wear protective goggles when opening drain cock and avoid the air stream. Failure to comply could result in injury to personnel.
- Wear protective goggles when underneath semitrailer. Failure to comply could result in injury to personnel.
- Pressurized air (100 psi/690 kPa) may cause injury to personnel or damage to equipment.
- Do not overtighten hose end brass fittings. The fittings should be installed finger tight with an additional 1 to 1-1/2 turns using a wrench. Do not twist hoses. Check for air leaks. Failure to follow this warning may cause the fittings to fail, brake lock-up, and possible injury or death to personnel.
- Improper cleaning methods and use of unauthorized cleaning liquids or solvents can injure personnel and damage equipment.
- Wear welding mask, gloves, and apron when welding or using cutting torch. Failure to wear adequate protective clothing may result in injury to personnel.
- Eye protection is required. Particles from grinding operations are hazardous to the eyes.

SUPPLEMENTAL WARNINGS

The following are commercial warnings from Chapter 11. These are subject to copyright protection and will not always conform to the Government's standards.

WARNING

AUTOMATIC SLACK ADJUSTERS

- Make sure the wheels are chocked before servicing the semitrailer. Release the parking brake and check that the push rod is fully released. If the push rod is not fully released, the ASA cannot be installed properly. Semitrailer movement may cause injury or death to personnel and damage to the equipment.
- DO NOT use an impact wrench or permanent internal damage will occur!

WARNING

BEARING REMOVAL AND INSTALLATION

Do not use compressed air to spin bearing rollers as injury to personnel may result if cage does not retain the rollers.

WARNING

ENHANCED EASY-STOP TRAILER ABS WITH PLC

- To prevent serious eye injury, always wear safe eye protection when you perform vehicle maintenance or service.
- The ABS is an electrical system. When you work on the ABS, take the same precautions that you must take with any electrical system to avoid serious personal injury. As with any electrical system, the danger of electrical shock or sparks exists that can ignite flammable substances. You must always disconnect the battery ground cable before working on the electrical system.
- Release all pressure from the air system before you disconnect any components. Pressurized air can cause serious personal injury.
- You must use a Schedule 80 hex nipple (3/4 in. NPTF) to mount the ECU/single modulator valve assembly securely to the air tank to avoid possible serious personal injury and damage to the component.

WARNING

KINGPIN MAINTENANCE AND REPLACEMENT RECOMMENDATIONS

When welding, use a procedure which assures a sound, good quality weld which protects the welding operator and others. Overwelding may cause distortion and damage and underwelding may not develop sufficient strength. A low hydrogen process and AWS 370XX filler metal are recommended. Take precautions to ensure that the vehicle electrical system is not damaged by the welding.

WARNING

LANDING GEAR

Ensure the landing leg scissor assembly retaining (locking) pins do not present a contact hazard to personnel. The pins can extend outward and cause injury to personnel.

WARNING

PRO-TORQ SPINDLE NUT

- Failure to follow this instruction could cause the wheel to come off and cause bodily injury. Failure to back off the nut will cause the bearing to run hot and be damaged.
- Failure to follow this instruction could cause the wheel to come off and cause bodily injury. Do not bend or manipulate keyway tang in any way. Doing so may cause the tang to break off in service.
- Failure to follow this instruction could cause the wheel to come off and cause bodily injury. The PRO-TORQ Spindle Nut is sold as an assembly with the keeper in place. DO NOT attempt to place the nut on the spindle or tighten or loosen the nut on the spindle while the keeper is locked inside the nut. Doing so may deform the keeper and allow the nut to unthread during operation.
- A new orange keeper arm must be replaced if it is damaged when removed or installed in the nut. It is recommended to replace the keeper arm each time it is removed. The original nut may be reused; the original keeper may be reused if not damaged. Failure to comply this warning may cause injury or death to personnel and damage to the equipment due to wheel-end loss.

WARNING

SEALED BRAKE INSTALLATION AND DISARMING

- A spring brake contains a very powerful compression spring. Failure to comply with all of the following instructions may result in forceful release of the piggyback or spring chamber and its contents which could cause death, severe personal injury and/or property damage.
- ALWAYS BLOCK WHEELS to prevent vehicle roll-away when performing any brake maintenance.
- DO NOT attempt to mechanically release (cage) the spring on a spring brake if it shows structural damage. Caging the spring or disassembly of the chamber may result in the forceful release of the spring chamber and its contents, which could cause death, severe personal injury, and/or property damage. Remove complete spring brake and replace with new unit.
- DISARM spring chamber before discarding old brake. To disarm, use a suitable safety chamber (see *Disarming Introduction* and *Disarming Instructions* in this work package). Failure to disarm assembly prior to disposal may, in time, result in spontaneous release of the spring chamber and its contents, causing death, personal injury, and/or property damage.
- Always block wheels to prevent vehicle roll-away when performing any brake maintenance. Failure to comply could cause injury or death to personnel.
- Step 7 only applies when spring brake is not pressurized. If air pressure is used to compress the spring, do not tighten release tool more than finger tight. Torquing the release tool nut while the spring brake is pressurized can cause pressure plate damage resulting in sudden release of the spring which could cause death or severe personal injury. Air pressure must be released after caging, prior to any disassembly.
- Place blocks under wheels to prevent vehicle roll-away before removing spring brake actuators. Failure to comply could cause injury or death to personnel.
- Incorrect push rod slack adjuster setup will result in improper brake operation, causing injury to personnel and damage to equipment.
- After installation, check for proper emergency operation, service operation, and brake adjustment. Failure to comply could cause injury to personnel and damage to equipment.

WARNING

SEALED BRAKE INSTALLATION AND DISARMING - CONTINUED

- Spring air brake chambers should never be rebuilt. Never attempt to loosen or remove the housing retaining clamp(s) bolts or repair the chamber in any way. Serious injury or death will occur.
 - a. This disarming chamber is to be fabricated at the Direct Support or higher level.
 - b. An annual inspection of this disarming chamber will be accomplished at the DOL or Depot Level QA/QC as is the case for tire cages.
 - c. DOL will certify inspection of the disarming chamber by stamping or applying data plate.
 - d. There will be NO substitution of ANY materials used to fabricate this chamber. Materials and welding standard/locations specified on the drawing are to be used in this fabrication. This is a safety device.
 - e. Never operate an acetylene gas torch without wearing proper clothing and eye protection.
- DO NOT cut the spring brake chamber clamp bolts before cutting the power spring coils. The spring coils MUST be cut FIRST. If this WARNING is NOT heeded, the spring will prematurely release 2,000 lb of pressure, and become an unexpected projectile that could cause injury or death to personnel and damage to the equipment.
- Do not place your hands or fingers inside the disarming chamber.

WARNING

SKF SCOTSEAL

Block wheels. Support vehicle on stands. Failure to do so could cause injury or death to personnel and damage to equipment.

WARNING

TIPS TO PROLONG LIGHTING LIFE

Certain lighting products generate heat. Care should be taken to avoid contact with flammable materials. The unit can generate enough heat to cause injury to personnel or damage to the equipment.

WARNING

TROUBLESHOOTING SPRING PARKING BRAKE

Do not loosen or remove chamber clamp ring. Injury or death to personnel could result.

LIST OF EFFECTIVE PAGES/WORK PACKAGES

NOTE: Zero in the “Change No.” column indicates an original page or work package.

Date of issue for the original manual is:

Original.... 30 September 2008

TOTAL NUMBER OF PAGES FOR FRONT AND REAR MATTER IS 36 AND TOTAL NUMBER OF WORK PACKAGES IS 112, CONSISTING OF THE FOLLOWING:

Page/WP No.	Change No.	Page/WP No.	Change No.
Front cover	0	WP 0023 (6 pgs)	0
a to f	0	WP 0024 (4 pgs)	0
i to x	0	WP 0025 (2 pgs)	0
Chapter 1 title page	0	WP 0026 (2 pgs)	0
WP 0001 (4 pgs)	0	WP 0027 (2 pgs)	0
WP 0002 (14 pgs)	0	WP 0028 (4 pgs)	0
WP 0003 (2 pgs)	0	WP 0029 (4 pgs)	0
Chapter 2 title page	0	WP 0030 (4 pgs)	0
WP 0004 (6 pgs)	0	WP 0031 (4 pgs)	0
WP 0005 (16 pgs)	0	WP 0032 (10 pgs)	0
WP 0006 (2 pgs)	0	WP 0033 (4 pgs)	0
Chapter 3 title page	0	WP 0034 (4 pgs)	0
WP 0007 (2 pgs)	0	WP 0035 (4 pgs)	0
WP 0008 (2 pgs)	0	WP 0036 (4 pgs)	0
WP 0009 (4 pgs)	0	WP 0037 (6 pgs)	0
Chapter 4 title page	0	WP 0038 (2 pgs)	0
WP 0010 (2 pgs)	0	WP 0039 (4 pgs)	0
WP 0011 (2 pgs)	0	WP 0040 (2 pgs)	0
WP 0012 (10 pgs)	0	WP 0041 (4 pgs)	0
Chapter 5 title page	0	WP 0042 (2 pgs)	0
WP 0013 (2 pgs)	0	WP 0043 (2 pgs)	0
WP 0014 (12 pgs)	0	WP 0044 (2 pgs)	0
Chapter 6 title page	0	WP 0045 (6 pgs)	0
WP 0015 (2 pgs)	0	WP 0046 (4 pgs)	0
WP 0016 (12 pgs)	0	WP 0047 (4 pgs)	0
Chapter 7 title page	0	WP 0048 (4 pgs)	0
WP 0017 (2 pgs)	0	WP 0049 (2 pgs)	0
WP 0018 (2 pgs)	0	WP 0050 (6 pgs)	0
WP 0019 (2 pgs)	0	WP 0051 (2 pgs)	0
WP 0020 (2 pgs)	0	WP 0052 (4 pgs)	0
WP 0021 (4 pgs)	0	WP 0053 (4 pgs)	0
WP 0022 (2 pgs)	0	WP 0054 (2 pgs)	0
Chapter 8 title page	0	WP 0055 (4 pgs)	0

Page/WP No.	Change No.	Page/WP No.	Change No.
WP 0056 (4 pgs)	0	WP 0084 (2 pgs)0
WP 0057 (4 pgs)	0	WP 0085 (8 pgs)0
WP 0058 (2 pgs)	0	WP 0086 (4 pgs)0
WP 0059 (2 pgs)	0	WP 0087 (2 pgs)0
WP 0060 (2 pgs)	0	WP 0088 (2 pgs)0
WP 0061 (6 pgs)	0	WP 0089 (4 pgs)0
WP 0062 (2 pgs)	0	WP 0090 (4 pgs)0
WP 0063 (2 pgs)	0	WP 0091 (4 pgs)0
WP 0064 (2 pgs)	0	WP 0092 (2 pgs)0
WP 0065 (2 pgs)	0	WP 0093 (2 pgs)0
WP 0066 (6 pgs)	0	WP 0094 (6 pgs)0
WP 0067 (8 pgs)	0	WP 0095 (2 pgs)0
WP 0068 (6 pgs)	0	WP 0096 (20 pgs)0
Chapter 9 title page0	WP 0097 (2 pgs)0
WP 0069 (6 pgs)	0	WP 0098 (6 pgs)0
WP 0070 (4 pgs)	0	WP 0099 (2 pgs)0
WP 0071 (6 pgs)	0	WP 0100 (4 pgs)0
WP 0072 (6 pgs)	0	WP 0101 (4 pgs)0
WP 0073 (2 pgs)	0	WP 0102 (2 pgs)0
WP 0074 (2 pgs)	0	WP 0103 (4 pgs)0
WP 0075 (6 pgs)	0	WP 0104 (4 pgs)0
WP 0076 (2 pgs)	0	WP 0105 (8 pgs)0
Chapter 10 title page0	WP 0106 (4 pgs)0
WP 0077 (6 pgs)	0	WP 0107 (2 pgs)0
WP 0078 (102 pgs)	0	WP 0108 (4 pgs)0
WP 0079 (14 pgs)	0	WP 0109 (2 pgs)0
Chapter 11 title page0	WP 0110 (4 pgs)0
WP 0080 (4 pgs)	0	WP 0111 (2 pgs)0
WP 0081 (4 pgs)	0	WP 0112 (2 pgs)0
WP 0082 (8 pgs)	0	Index-1 to Index-60
WP 0083 (4 pgs)	0	Back Cover0

TECHNICAL MANUAL

**FIELD AND SUSTAINMENT MAINTENANCE MANUAL
(INCLUDES REPAIR PARTS AND SPECIAL TOOLS LIST)**

FOR

**SEMITRAILER, TACTICAL, BREAKBULK/CONTAINER
TRANSPORTER, 22-1/2 TON, RESET
M871R (NSN 2330-01-528-6690) (EIC: CAN)
M871A1R (NSN 2330-01-528-6673) (EIC: CAM)
M871A2R (NSN 2330-01-528-6698) (EIC: CAK)**

REPORTING ERRORS AND RECOMMENDING IMPROVEMENTS

You can help improve this publication. If you find any errors, or if you would like to recommend any improvements to the procedures in this publication, please let us know. The preferred method is to submit your DA Form 2028 (Recommended Changes to Publications and Blank Forms) through the Internet, on the Army Electronic Product Support (AEPS) website. The Internet address is <https://aeps.ria.army.mil>. The DA Form 2028 is located under the Public Applications section in the AEPS Public Home Page. Fill out the form and click on SUBMIT. Using this form on the AEPS will enable us to respond quicker to your comments and better manage the DA Form 2028 program. You may also mail, e-mail, or fax your comments or DA Form 2028 directly to the U.S. Army TACOM Life Cycle Management Command. The postal mail address is U.S. Army TACOM Life Cycle Management Command, ATTN: AMSTA-LC-LMPP / TECH PUBS, 1 Rock Island Arsenal, Rock Island, IL 61299-7630. The e-mail address is tacoml-cmc.daform2028@us.army.mil. The fax number is DSN 793-0726 or Commercial (309) 782-0726.

DISTRIBUTION STATEMENT A - Approved for public release; distribution is unlimited.

TABLE OF CONTENTS

	<u>Page No.</u>	<u>WP Sequence No.</u>
How to Use This Manual	ix/(x Blank)	
Chapter 1 - INTRODUCTORY INFORMATION, EQUIPMENT DESCRIPTION AND DATA, AND THEORY OF OPERATION		
General Information	WP 0001	
Equipment Description and Data	WP 0002	
Theory of Operation	WP 0003	
Chapter 2 - OPERATOR INSTRUCTIONS		
Description and Use of Operator's Controls and Indicators	WP 0004	
Operation Under Usual Conditions	WP 0005	
Operation Under Unusual Conditions	WP 0006	
Chapter 3 - OPERATOR TROUBLESHOOTING PROCEDURES		
Operator Troubleshooting Introduction	WP 0007	
Operator Troubleshooting Symptom Index	WP 0008	
Operator Troubleshooting Procedures	WP 0009	
Chapter 4 - ORGANIZATIONAL TROUBLESHOOTING PROCEDURES		
Organizational Troubleshooting Introduction	WP 0010	
Organizational Troubleshooting Symptom Index	WP 0011	
Organizational Troubleshooting Procedures	WP 0012	
Chapter 5 - OPERATOR PMCS MAINTENANCE		
Operator PMCS Introduction	WP 0013	
Operator PMCS	WP 0014	
Chapter 6 - ORGANIZATIONAL PMCS MAINTENANCE		
Organizational PMCS Introduction	WP 0015	
Organizational PMCS	WP 0016	
Chapter 7 - OPERATOR MAINTENANCE		
Electrical Connectors Cleaning	WP 0017	
Air Reservoirs Service	WP 0018	
Gladhands Cleaning	WP 0019	
Landing Gear Legs Cleaning	WP 0020	
Tire and Wheel Assembly Replacement	WP 0021	
Spare Tire and Wheel Assembly Replacement	WP 0022	
Chapter 8 - ORGANIZATIONAL MAINTENANCE		
General Maintenance Instructions	WP 0023	
Wire Connectors Repair	WP 0024	
Blackout Lights Replacement	WP 0025	
Clearance Lights Replacement	WP 0026	
LED Taillights Replacement	WP 0027	
Receptacle Converter Box Replacement (M871R and M871A1R)	WP 0028	
Receptacle Converter Box and Nose Plate Replacement (M871A2R)	WP 0029	

TABLE OF CONTENTS - CONTINUED

	<u>Page No.</u>	<u>WP Sequence No.</u>
Chapter 8 - ORGANIZATIONAL MAINTENANCE - CONTINUED		
Wiring Harnesses Replacement	WP 0030	
Service Brakes - S-Camshaft Replacement	WP 0031	
Service Brakes - Shoes and Lining Replacement	WP 0032	
Hubs and Drums Replacement	WP 0033	
Automatic Slack Adjusters Maintenance	WP 0034	
ECU Valve Replacement	WP 0035	
ABS Brake Power Connections Replacement	WP 0036	
Air Lines and Fittings Replacement	WP 0037	
Air Brake Chambers Replacement	WP 0038	
Air Reservoirs Replacement	WP 0039	
Air Brake Chamber Control Valve Replacement	WP 0040	
Gladhands Replacement (M871R)	WP 0041	
Gladhands Replacement (M871A1R and M871A2R)	WP 0042	
Dock Bumpers Replacement (M871R and M871A1R)	WP 0043	
Dock Bumpers Replacement (M871A2R)	WP 0044	
Retractable Twist Locks Maintenance (M871R and M871A1R)	WP 0045	
Retractable Twist Locks Replacement (M871A2R)	WP 0046	
Tiedown Rings Maintenance	WP 0047	
Spare Tire Carrier Maintenance	WP 0048	
Wheel Chocks Repair	WP 0049	
Landing Gear Replacement	WP 0050	
Ground Boards Replacement	WP 0051	
Bulkhead Replacement	WP 0052	
Corner and Side Stakes Replacement	WP 0053	
Antisail Mud Flaps Replacement	WP 0054	
Floor Deck Boards Replacement (M871R and M871A1R)	WP 0055	
Floor Deck Boards Replacement (M871A2R)	WP 0056	
Stowage Box Replacement	WP 0057	
Manifest Box Replacement	WP 0058	
Ladder Bracket Replacement	WP 0059	
Reflectors Replacement	WP 0060	
Decals and Data Plates Replacement	WP 0061	
ABS Warning Light Replacement	WP 0062	
HUBODOMETER® Replacement	WP 0063	
Conspicuity Tape Replacement	WP 0064	
Service Upon Receipt	WP 0065	
Preparation for Storage or Shipment	WP 0066	
Lubrication Instructions	WP 0067	

TABLE OF CONTENTS - CONTINUED

	<u>Page No.</u>	<u>WP Sequence No.</u>
Chapter 8 - ORGANIZATIONAL MAINTENANCE - CONTINUED		
Torque Limits		WP 0068
Chapter 9 - DIRECT SUPPORT AND GENERAL SUPPORT MAINTENANCE		
Direct Support and General Support Maintenance Instructions		WP 0069
Stowage Box Side Panels Replacement		WP 0070
Suspension Replacement (M871R and M871A1R)		WP 0071
Suspension Replacement (M871A2R)		WP 0072
Frame Repair		WP 0073
Kingpin Replacement (M871R and M871A1R)		WP 0074
Kingpin Replacement (M871A2R)		WP 0075
Tire Repair		WP 0076
Chapter 10 - PARTS INFORMATION		
Repair Parts and Special Tools List Introduction		WP 0077
Repair Parts List		WP 0078
GROUP 06 ELECTRICAL SYSTEM.0078-3	
0609 LIGHTS0078-3	
BLACKOUT LIGHT0078-3	
CLEARANCE LIGHTS0078-5	
LED TAILLIGHT0078-7	
0613 HULL OR CHASSIS WIRING HARNESS0078-9	
CONVERTER ASSEMBLY UNIT0078-9	
CHASSIS WIRING HARNESS0078-11	
GROUP 11 REAR AXLE0078-13	
1100 REAR AXLE ASSEMBLY0078-13	
AXLE ASSEMBLY0078-13	
GROUP 12 BRAKES0078-15	
1202 SERVICE BRAKES0078-15	
BRAKE CAMSHAFT COMPONENTS0078-15	
SERVICE BRAKE COMPONENTS0078-17	
1206 MECHANICAL BRAKE SYSTEM0078-19	
SLACK ADJUSTER0078-19	
1207 ELECTRICAL BRAKE SYSTEM0078-21	
ECU/VALVE ASSEMBLY0078-21	
ABS BRAKE POWER HARNESS AND SENSOR0078-23	
1208 AIR BRAKE SYSTEM0078-25	
AIR LINES AND FITTINGS0078-25	
AIR BRAKE CHAMBER0078-27	
AIR RESERVOIRS0078-29	
AIR BRAKE CHAMBER CONTROL VALVE0078-31	

TABLE OF CONTENTS - CONTINUED

	<u>Page No.</u>	<u>WP Sequence No.</u>
Chapter 10 - PARTS INFORMATION - CONTINUED		
GLADHANDS0078-33	
GROUP 13 WHEEL AND TRACKS0078-35	
1311 WHEEL ASSEMBLY0078-35	
HUB AND DRUM0078-35	
WHEEL ASSEMBLY0078-37	
1313 TIRES, TUBES, TIRE CHAINS0078-39	
TIRE0078-39	
GROUP 15 FRAME, TOWING ATTACHMENTS, DRAWBARS, AND ARTICULATION SYSTEMS0078-43	
1501 FRAME ASSEMBLY0078-43	
RETRACTABLE TWIST LOCK0078-43	
LIFTING, TIEDOWN RING, LADDER, COVER PLATE, AND RELATED PARTS0078-47	
1504 SPARE WHEEL CARRIER AND TIRE LOCK0078-49	
SPARE TIRE CARRIER0078-49	
1506 FIFTH WHEEL0078-51	
KINGPIN0078-51	
1507 LANDING GEAR, LEVELING JACKS0078-55	
LANDING GEAR0078-55	
GROUND BOARD ASSEMBLY AND CHOCK BLOCKS0078-59	
GROUP 16 SPRINGS AND SHOCK ABSORBERS0078-63	
1601 SPRINGS0078-63	
SUSPENSION0078-63	
GROUP 18 BODY, CAB, HOOD, AND HULL0078-67	
1801 BODY, CAB, HOOD, AND HULL ASSEMBLIES0078-67	
BULKHEAD AND STOWAGE RACK ASSEMBLY0078-67	
FRONT, SIDE, AND REAR STAKES0078-69	
SIDE AND REAR BOARDS0078-71	
MUD FLAPS0078-73	
1805 FLOORS, SUBFLOORS, AND RELATED COMPONENTS0078-77	
FLOOR DECKING0078-77	
1808 BULKHEAD, BOXES, STRAPS, CARRYING CASES, CABLE REELS, HOSE REELS, ETC.0078-81	
STOWAGE BOX0078-81	
MANIFEST BOX0078-83	
GROUP 21 BUMPERS, GUARDS, AND MARINE FENDERS0078-85	
2101 BUMPERS, BRACKETS, GUARDS, AND PROTECTIVE DEVICES0078-85	
RUBBER DOCK BUMPERS0078-85	

TABLE OF CONTENTS - CONTINUED

	<u>Page No.</u>	<u>WP Sequence No.</u>
Chapter 10 - PARTS INFORMATION - CONTINUED		
GROUP 22 BODY, CHASSIS AND HULL ACCESSORY ITEMS	0078-87	
2202 ACCESSORY ITEMS	0078-87	
REFLECTORS	0078-87	
REFLECTIVE TAPE	0078-89	
2210 DATA PLATES AND INSTRUCTION HOLDERS	0078-93	
DATA PLATES	0078-93	
GROUP 42 ELECTRICAL EQUIPMENT	0078-95	
4209 SIGNALING DEVICES	0078-95	
ABS WARNING LIGHT	0078-95	
GROUP 47 GAGES (NON-ELECTRICAL), WEIGHTING AND MEASURING DEVICES	0078-97	
4701 INSTRUMENTS	0078-97	
HUBODOMETER®	0078-97	
GROUP 94 REPAIR KITS	0078-99	
9401 REPAIR KITS	0078-99	
KITS	0078-99	
GROUP 95 GENERAL USE STANDARDIZED PARTS	0078-101	
9501 HARDWARE SUPPLIES AND BULK MATERIEL, COMMON	0078-101	
BULK	0078-101	
NSN and P/N Indexes		WP 0079
Chapter 11 - SUPPORTING INFORMATION		
References		WP 0080
Maintenance Allocation Chart (MAC) Introduction		WP 0081
Maintenance Allocation Chart (MAC)		WP 0082
Basic Issue Items (BII) List		WP 0083
Additional Authorization List (AAL)		WP 0084
Expendable and Durable Items List		WP 0085
10/20 Inspection Checklist		WP 0086
Converting Fractions to Decimals and Metric Equivalents		WP 0087
Fastener Size and Thread Pattern		WP 0088
Receptacle Converter Box Maintenance		WP 0089
Kingpin Maintenance and Replacement Recommendations		WP 0090
Fifth Wheel and Upper Coupler Connections		WP 0091
Coupling Instructions		WP 0092
Technical Information for LED and Filament Bulb Lighting		WP 0093
10 Tire Tips		WP 0094
Landing Gear Operating, Maintenance, and Repair Procedures		WP 0095
Sealed Brake Installation and Disarming		WP 0096

TABLE OF CONTENTS - CONTINUED

	<u>Page No.</u>	<u>WP Sequence No.</u>
Chapter 11 - SUPPORTING INFORMATION - CONTINUED		
Hub Piloted Disc Wheels		WP 0097
OSHA Standard Multi- and Single-Piece Wheel		WP 0098
Troubleshooting Hubs		WP 0099
Troubleshooting Wheel Problems		WP 0100
Troubleshooting Brake Drums		WP 0101
Troubleshooting Spring Parking Brake		WP 0102
SKF Scotseal		WP 0103
Bearing Removal and Installation		WP 0104
Enhanced Easy-Stop Trailer ABS with PLC		WP 0105
Brake Drum Re-Bore Limits and/or Maximum Wear Diameter		WP 0106
Service Brakes S-Camshafts and Shoes		WP 0107
Pro-Torq Spindle Nut		WP 0108
HUBODOMETER®		WP 0109
Automatic Slack Adjusters		WP 0110
Axle Alignment		WP 0111
Axle Identification		WP 0112
Index		INDEX-1

FEATURES OF THIS MANUAL

1. WARNINGS, CAUTIONS, and NOTES are as follows:

WARNING

A WARNING indicates a hazard which may result in injury or death to personnel.

CAUTION

A CAUTION is a reminder of safety practices or directs attention to usage practices that may result in damage to equipment.

NOTE

A NOTE is a statement containing information that will make the procedures easier to perform.

2. Statements and words of particular interest may be printed in underlined or CAPITAL letters to create emphasis.
3. Within a procedural step, reference may be made to another work package in this manual or to another manual. These references indicate where you should look for more complete information.
4. Illustrations are placed after, and as close to, the procedural steps to which they apply. Callouts placed on the art are text or numbers.
5. Numbers located at lower right corner of art (e.g., 447-0001; 447-0002) are art control numbers and are used for tracking purposes only.
6. Technical instructions include metric units as well as standard units. For your reference, a *Metric Conversion Chart* is located on the inside back cover of this manual.

CHAPTER 1
INTRODUCTORY INFORMATION, EQUIPMENT
DESCRIPTION AND DATA, AND THEORY OF OPERATION

FIELD AND SUSTAINMENT MAINTENANCE**GENERAL INFORMATION**

SCOPE

1. **Type of Manual.** This manual is an: Operator's, Organizational, Direct Support, and General Support Maintenance Manual (including Repair Parts and Special Tools List).
2. **Equipment Name and Model Number.**
 - a. M871R, Semitrailer, Tactical, Breakbulk/Container Transporter, 22-1/2 Ton, Reset, NSN 2330-01-528-6690
 - b. M871A1R, Semitrailer, Tactical, Breakbulk/Container Transporter, 22-1/2 Ton, Reset, NSN 2330-01-528-6673
 - c. M871A2R, Semitrailer, Tactical, Breakbulk/Container Transporter, 22-1/2 Ton, Reset, NSN 2330-01-528-6698
3. **Purpose of Equipment.** The semitrailers are used to transport containerized American National Standard Institute/International Organization for Standardization (ANSI/ISO), breakbulk cargo, or ammunition on highways or off-roads.

MAINTENANCE FORMS, RECORDS, AND REPORTS

Department of the Army forms and procedures used for the equipment maintenance will be those prescribed by DA PAM 750-8, *The Army Maintenance Management System (TAMMS) User Manual*.

REPORTING EQUIPMENT IMPROVEMENT RECOMMENDATIONS (EIR)

If your semitrailer needs improvement, let us know. Send us an EIR. You, the user, are the only one who can tell us what you do not like about your equipment. Let us know why you do not like the design or performance. If you have Internet access, the easiest and fastest way to report problems or suggestions is to go to <https://aeps.ria.army.mil/aepspublic.cfm> (scroll down and choose the "Submit Quality Deficiency Report" bar). The Internet form lets you choose to submit an EIR, a Product Quality Deficiency Report (PQDR), or a Warranty Claim Action (WCA). You may also submit your information using an SF Form 368 (*Product Quality Deficiency Report*). You can send your SF Form 368 via e-mail, regular mail, or facsimile using the addresses/facsimile numbers specified in DA PAM 750-8, *TAMMS User Manual*. We will send you a reply.

CORROSION PREVENTION AND CONTROL (CPC)

1. CPC of Army materiel is a continuing concern. It is important that any corrosion problems with this item be reported so that the problem can be corrected and improvements can be made to prevent the problem in future items.
2. Corrosion specifically occurs with metals. It is an electrochemical process that causes the degradation of metals. It is commonly caused by exposure to moisture, acids, bases, or salts. An example is the rusting of iron. Corrosion damage in metals can be seen, depending on the metal, as tarnishing, pitting, fogging, surface residue, and/or cracking.
3. Plastics, composites, and rubbers can also degrade. Degradation is caused by thermal (heat), oxidation (oxygen), solvation (solvents), or photolytic (light, typically UV) processes. The most common exposures are excessive heat or light. Damage from these processes will appear as cracking, softening, swelling, and/or breaking.
4. SF Form 368, *Product Quality Deficiency Report* should be submitted to the address specified in DA PAM 750-8, *TAMMS User Manual*.

DESTRUCTION OF ARMY MATERIEL TO PREVENT ENEMY USE

For destruction of Army materiel to prevent enemy use, refer to TM 750-244-3.

PREPARATION FOR STORAGE OR SHIPMENT

Refer to WP 0066 for storage and shipment information.

TRANSPORTABILITY**NOTE**

Specific tiedown transportability data for rail, truck, and fixed wing air movement can be found in MTMCTEA PAM 55-19, MTMCTEA PAM 55-20, and MTMCTEA PAM 55-24, respectively.

1. Reset models are transportable in a C-141 fixed wing aircraft at the load master's discretion dependant on height of cargo.

NOTE

The bulkhead is removable.

2. Reset models, loaded/unloaded, are transportable by C-5 and C-5A fixed wing aircraft.
3. Reset models, loaded/unloaded, are transportable by C-17 fixed wing aircraft.
4. Reset models, loaded/unloaded, are transportable by rail and with ISO container (CONUS).
5. Reset models, loaded/unloaded/ are transportable by ship.
6. Reset models may be stacked, two semitrailers, bulkhead to bulkhead for transport by a prime mover.
7. Reset models, loaded/unloaded, are transportable by barge as dictated by the length of the semitrailer and barge load capacity.
8. Reset models, unloaded, are transportable by rotary wing aircraft (CH-47). Refer to FM 10-450-5.
9. Reset models, unloaded, are transportable in C-130 fixed wing aircraft.

WARRANTY

A one (1) to five (5) year warranty on these RRS semitrailers, the same as identified for the M871A3 semitrailer in TB 9-2330-326-14, with the exception that the actual semitrailer structure only has a one (1) year warranty. The warranty period begins upon acceptance of the RRS semitrailers by the government (DD250 date) at the manufacturer's plant.

LIST OF ABBREVIATIONS/ACRONYMS

NOTE

Refer to ASME Y14.38-1999, *Abbreviations and Acronyms*, for standard abbreviations.

ABBREVIATION/ACRONYM	DEFINITION
AAL.....	Additional Authorization List
ANSI.....	American National Standard Institute
A/R.....	As Required
BII.....	Basic Issue Items
BO.....	Blackout
C.....	Celsius
cm.....	Centimeters
COEI.....	Components of End Item
CONUS.....	Continental United States
CPC.....	Corrosion Prevention and Control
ECU.....	Electronic Control Unit
EIR.....	Equipment Improvement Recommendations
F.....	Fahrenheit
ISO.....	International Organization for Standardization
kg.....	Kilograms
km.....	Kilometers
kph.....	Kilometers per Hour
kW.....	Kilowatts
L.....	Liters
lb-ft.....	Pound-Feet
m.....	Meters
mm.....	Millimeters
MWO.....	Modification Work Order
NATO.....	North Atlantic Treaty Organization
Nm.....	Newton-Meters
PMCS.....	Preventive Maintenance Checks and Services
RFID.....	Radio Frequency Identification Device
TB.....	Technical Bulletin
TOE/MTOE.....	Table of Organization and Equipment/Modified Table of Organization and Equipment
UID.....	Unit Identification Device

END OF WORK PACKAGE

FIELD AND SUSTAINMENT MAINTENANCE**EQUIPMENT DESCRIPTION AND DATA**

EQUIPMENT CHARACTERISTICS, CAPABILITIES, AND FEATURES

1. The semitrailer is easily configured for either breakbulk or containerized cargo.

WARNING

- Do not tow the semitrailer with the M52, M52A1, or M52A2 truck tractor. The M52 series inherent design capabilities are not compatible with the semitrailer, and use would result in a serious compromise to the safety of personnel and equipment.
 - When towing the semitrailer with the M818, M931 series, or M932 series tractors, the fifth wheel wedges on the M818 are to be in the locked-in (pushed-in) mode for highway and secondary road use, and in the locked-out (pulled-out) mode for cross-country operation. Failure to follow this warning may result in injury to personnel or damage to equipment.
2. The semitrailer can be towed by the M915 for improved highway use only, or the M818, M931, and M932 for either highway or off-road.
 3. The semitrailer can carry up to 45,000 lb (20,412 kg) of cargo.
 4. The semitrailer's side racks are easily installed or removed.

WARNING

Under no circumstances shall speeds exceed the following:

- Highway: 55 mph (89 kph)
- Secondary: 35 mph (56 kph)
- Trails: 15 mph (24 kph)
- Rough: 10 mph (16 kph)

Failure to observe this warning may result in injury to personnel or damage to equipment.

LOCATION AND DESCRIPTION OF MAJOR COMPONENTS

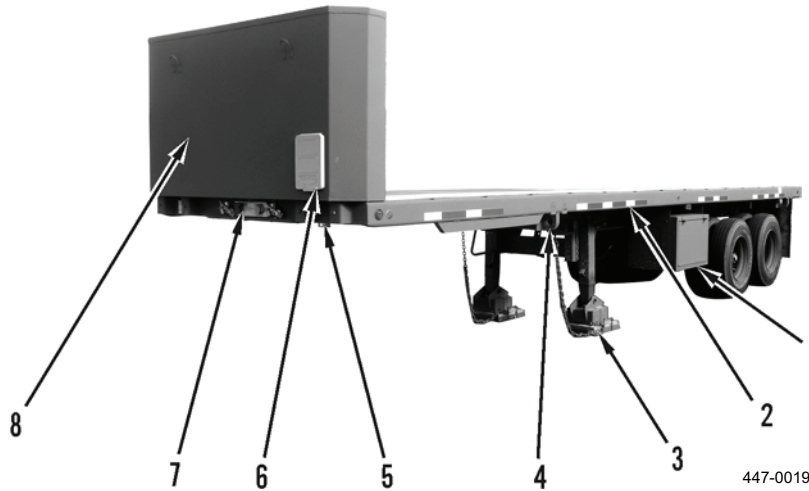

Figure 1. Left-Front View.

KEY	COMPONENT	DESCRIPTION
1	Stowage Box	Used to store BII and AAL items. It is a bolt-on box.
2	Conspicuity Tape	Provides highly reflected areas, making the semitrailer more noticeable to enhance safety.
3	Landing Legs	Using the handcrank, the landing legs can be manually extended when the semitrailer is uncoupled from the towing vehicle, and manually retracted when the semitrailer is coupled to the towing vehicle.
4	Front Lift/Tiedown Points	Used to lift or tie down the semitrailer. One on each side.
5	Kingpin	Connects the semitrailer to the fifth wheel of the towing vehicle.
6	Manifest Box	Used to store the cargo manifests.
7	Receptacle Converter Box	Contains the electrical connections.
8	Bulkhead, Removable	Constructed of steel. When carrying breakbulk cargo with the side and rear panels installed, the bulkhead will keep the load from shifting forward. Can also be used to store the ladder and side and rear panels. Bulkhead is removable.

NOTE

The RFID tag is for shipping purposes only. A mounting bracket may or may not be present. Mounting locations may vary.

LOCATION AND DESCRIPTION OF MAJOR COMPONENTS - CONTINUED

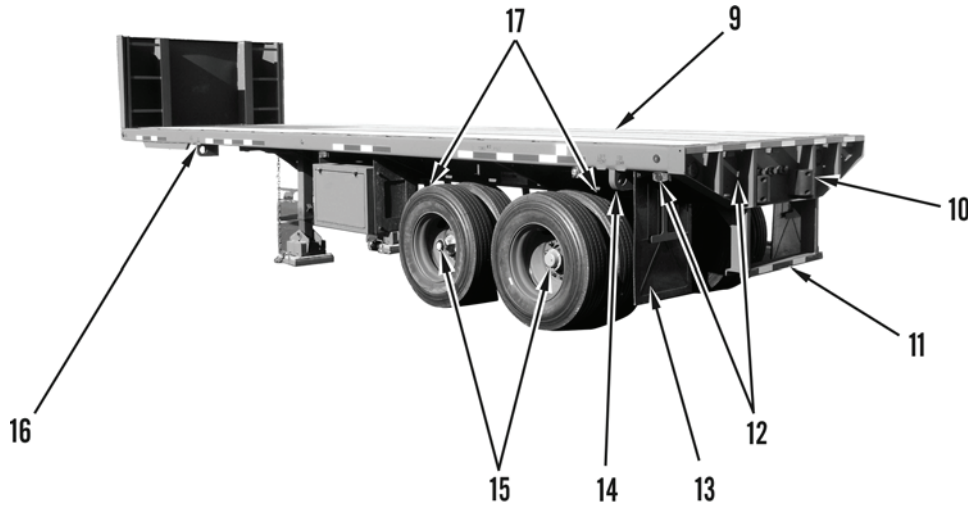

447-0020

Figure 2. Left-Rear View.

KEY	COMPONENT	DESCRIPTION
9	Floor Deck Boards	Screwed to the frame for easy maintenance.
10	Rubber Bumpers	Prevent damage to the semitrailer and the dock when loading and unloading.
11	Rear Bumper	Prevents damage to the suspension when backing the semitrailer into the dock.
12	Service Lights	Include blackout, clearance, and LED taillights.
13	Antisail Mud Flaps	Keep mud and water from being splashed off to the rear. Also keep rocks from being thrown off to the rear when traveling on unimproved roads.
14	Rear Lift/Tiedown Points	Used to lift or tie down the semitrailer. One on each side.
15	Tandem Axles	Consist of the suspension system, brake system, axles, and tires.
16	Frame	Constructed of steel. Provides the load-bearing surface and the mounting for the axles, suspension, kingpin, bulkhead, and side racks.
17	Air Reservoirs Pressure Release Pull Cables	When pulled, opens drain valve and allows air pressure to drain from air reservoir.

LOCATION AND DESCRIPTION OF MAJOR COMPONENTS - CONTINUED

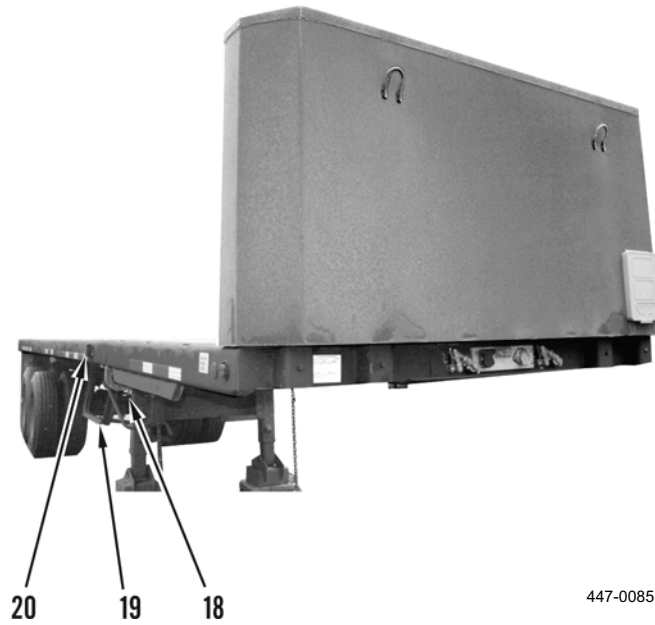
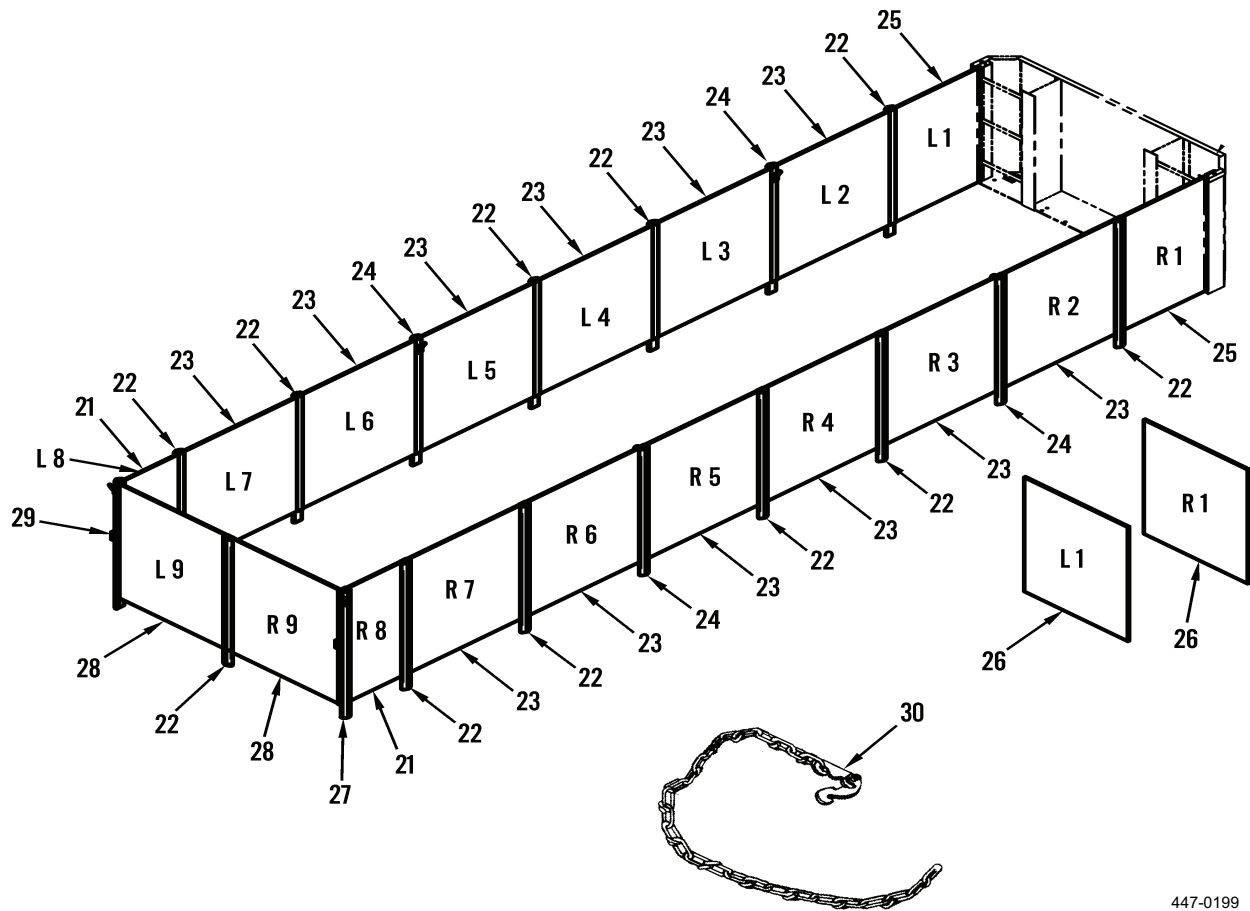

Figure 3. Right-Front View.

KEY	COMPONENT	DESCRIPTION
18	Handcrank	Rotating the handcrank operates the landing gear, which in turn extends or retracts the landing legs.
19	Spare Tire Carrier	Carries and secures the spare tire.
20	Ladder Bracket	Used to hold the ladder in place.

LOCATION AND DESCRIPTION OF MAJOR COMPONENTS - CONTINUED



447-0199

Figure 4. Panels and Stakes.

KEY	COMPONENT	DESCRIPTION
21	Side Panels	Quantity: 2. Size: 23-3/4 x 48 x 1/2 in. (60 x 122 x 1.3 cm). Can be stored in bulkhead.
22	Side Stakes	Quantity: 11. Can be stored in bulkhead.
23	Side Panels	Quantity: 12. Size: 47-3/4 x 48 x 1/2 in. (121 x 122 x 1.3 cm). Can be stored in bulkhead.
24	Side Stakes w/Loop and Lanyard	Quantity: 4. Can be stored in bulkhead.
25	Side Panels (M871R and M871A1R)	Quantity: 2. Size: 35-3/4 x 48 x 1/2 in. (91 x 122 x 1.3 cm). Can be stored in bulkhead.
26	Side Panels (M871A2R)	Quantity: 2. Size: 42 x 48 x 1/2 in. (107 x 122 x 1.3 cm). Can be stored in bulkhead.
27	Right-Rear Corner Stake w/Loop and Handle	Quantity: 1. Can be stored in bulkhead.
28	Rear Panels	Quantity: 2. Size 44 x 48 x 1/2 in. (112 x 122 x 1.3 cm). Can be stored in bulkhead.
29	Left-Rear Corner Stake w/Loop and Handle	Quantity: 1. Can be stored in bulkhead.
30	Chain Assemblies	Quantity: 4. Can be stored in stowage box.

M871R AND M871A1R EQUIPMENT DATA

Semitrailer

Kingpin Diameter	2 in. (5.08 cm)
Kingpin to Front of Chassis	28 in. (71 cm)
Kingpin to Landing Leg	100 in. (254 cm)
Dimensions Overall:	
Length	357.6 in. (908.3 cm)
Width	96 in. (243.8 cm)
Height	103 in. (262 cm)
Floor Height (empty)	55 in. (140 cm)
Floor Height (loaded)	54 in. (137 cm)
Upper Fifth Wheel Plate Height (loaded)	46 in. (117 cm)
Track (tread center-to-center of tires)	53 in. (135 cm)
Empty Weight	15,630 lb (7,090 kg)
Payload:	
Hard Surface Roads	45,000 lb (20,412 kg)
Cross Country	45,000 lb (20,412 kg)
Center of Gravity Forward of Suspension:	
Loaded	176 in. (447 cm)
Empty	166 in. (422 cm)
Angle of Departure (loaded)	50 degrees
Ground Clearance (from bottom of axle)	18 in. (46 cm)
Fording Depth	30 in. (76 cm)

M871R, M871A1R, M871A2R EQUIPMENT DATA**Bridge Classification**

Empty with Prime Mover	Class 14
Empty w/o Prime Mover	Class 6
Cross-Country Loaded with Prime Mover	Class 25
Cross-Country Loaded w/o Prime Mover	Class 18
Highway Loaded with Prime Mover	Class 30
Highway Loaded w/o Prime Mover	Class 22

HUBODOMETER®

Manufacturer	Stemco
Accuracy	± 2%
Factory Calibration	Calibrated to Mid-Life of Tire Available Factory Preset Mileage on Replacement HUBODOMETER®
Model (part number)	50086021

Wheel: Hub-Piloted

Manufacturer	Motor Wheel
Quantity (including spare)	9
Size	22.5 x 8.25
Material	Steel
Stud Holes	10
Type	1 Piece
Flange Nut Torque	450 to 500 lb-ft (610 to 678 Nm)
Type of Nut	Flange, All Right-Hand Threads
Lug Nut Size	1-5/16 in. (3.18 cm)

Tires

Manufacturer	Michelin
Quantity (including spare)	9
Type	Tubeless Radial
Size	11R22.5
Ply Rating (actual)	16 Ply
Load Range	H
Cold Inflation Pressure (all)	115 psi (793 kPa)
Tire Weight	95.7 lb (43.41 kg)
Diameter	36.7 in. (93.22 cm)
Loaded Section Width	11.0 in. (28 cm)
Tread Depth New	18/32 (9/16 in. [14.3 mm])

M871R, M871A1R, M871A2R EQUIPMENT DATA - CONTINUED

Mission Profile Maximum Speeds

Highway 55 mph	25%
Secondary 35 mph	60%
Trails 15 mph	10%
Rough 10 mph	5%

Axles

Manufacturer	Meritor
Number of Axles	2 (dual tandem)
Tube Diameter	5 in. (12.7 cm)
Tube Wall Thickness (heavy)	5/8 in. (15.9 mm)
Model Number	TQ4671Q2405TOA
Series	167H715ABS
Load Capacity (DOT rating)	20,000 lb (9,072 kg)
Beam Capacity	25,000 lb (11,340 kg)
Spindle, Center to Spindle Center Between Axles	49 in. (124.5 cm)
Track, Center to Center of Dual Wheels	71-1/2 in. (181.6 cm)

Brakes

Manufacturer	Meritor
Series	Q-Plus Series
Size	16-1/2 x 7 in. (42 x 18 cm)
Type	Non-Asbestos
Activation	Air
System Air Pressure	100 to 125 psi (689 to 862 kPa)
Lining and Shoe	Assembled

Brake Drum

Manufacturer	Webb
Material	Sintered Iron Drum Inside
Inside Diameter	16-1/2 in. (42 cm)

Wheel Bearings

Manufacturer	Timken
Part Number, Inner (cone and rollers)	HM218248
Part Number, Outer (cone and rollers)	HM212049

Grease Seal

Manufacturer	Scotseal (Chicago Rawhide)
Lip Style	46305 Classic, Triple Sealing Lips
Installation	Tool with Centering Plug Driven into Hub Bore, Pressfit

M871R, M871A1R, M871A2R EQUIPMENT DATA - CONTINUED

S-Cams

ManufacturerMeritor
 Length24-9/64 in. (61.5 cm)
 No. of Splines28
 Shaft Diameter1-1/2 in. (3.8 cm)
 Head Bushing Journal Size 1.62 in. (4.1 cm)
 Application 16-1/2 in. (42 cm) Brakes

Hubs

Manufacturer Webb
 No. of Studs10
 Type ABS with Tone Ring Mounted

Automatic Slack Adjusters

Manufacturer Haldex
 Series 409-10683
 Model 5-1/2 in. (14 cm)
 No. of Splines 28

Air Brake Chambers

Manufacturer Haldex/Anchorlok
 Stroke 3.00 in. (7.62 cm)
 Weight 20.2 lb (9.2 kg) each
 Type Long Stroke
 Part Number 166407
 Model Number 3030-GC-LS
 System Air Pressure:
 Minimum 100 psi (689 kPa)
 Maximum 115 psi (793 kPa)

M871R, M871A1R, M871A2R EQUIPMENT DATA - CONTINUED

Landing Legs

Manufacturer	Binkley (Parts Supplier: Fontaine Trailer Co.)
Shoe Type.	Locking Scissors (Fontaine)
Model	50,000 No Lube
Crank Radius	16-1/2 in. (42 cm)
Operation	2 Speed (high and low)
Retracted Height	40 in. (102 cm)
Extended Height.	57.5 in. (146.1 cm)
Lifting Capacity (static).	170,000 lb (77,111 kg)
Retracted Ground to Shoe Height	24 in. (61 cm)
Side Load per Leg	Up to 20,000 lb/leg
Operational Temperature	Range -65 to 250°F (-54 to -121°C)
Enhanced Grease System.	Cranking Effort Reduced 10 to 15%
High Gear Ratio	4.5 to 1
Low Gear Ratio	34.4 to 1

Suspension/Trunnion

Manufacturer	Hutchens Industries
Type	Single Point
Model	H 900-50
Springs	7 per pack, 2 packs
Leaf Width.	5 in. (13 cm)
Capacity	50,000 lb (22,680 kg)
Axle Spacing Sprung	51-1/2 in. (130.8 cm)
Trunnion Centers (TC).	22-1/8 in. (56.4 cm)
Spring Centers (SC)	38 in. (97 cm)

M871R and M871A1R

Trunnion/Axle Configuration.	Overslung (OS) Axles
Overslung (OS) Trunnion:	
Trunnion Hanger Height.	4-1/2 in. (11.4 cm)
Trunnion Bushing	Polyurethane P/N: 20248-01 Full Orbitration

M871A2R

Trunnion/Axle Configuration	Overslung (OS) Axles Underslung (US) Trunnion
---------------------------------------	---

M871R, M871A1R, M871A2R EQUIPMENT DATA - CONTINUED

Converter/Main Electrical System

Manufacturer of Converter Box Weldon Technologies, Inc.
 Converter Box (military) Solid State
 Type of Ground System Negative
 System Voltage 12/24V
 Tractor/Semitrailer Multiplexing Capability

Lighting

Blackout Lights 24V
 Clearance Lights LED 12/24V
 Stop, Turn, Taillights LED 12/24V
 ABS Warning Lights 12V

ABS System

Manufacturer Meritor WABCO
 Model 4S/2M
 System 4 Wheel Sensors, 1 ECU, 2 Modulators
 Diagnostic Tool Blink Code Adapter
 Modulator Valves 1 External, 1 Internal (part of ECU)
 ECU 12V

Hidden Manufacturer's Serial Number

Registration number is stamped into front deck underside frame between landing legs.

M871R, M871A1R, M871A2R EQUIPMENT DATA - CONTINUED

Component Weight Data

Bulkhead557 lb (253.4 kg)
Landing Leg with Gear200 lb (90.7 kg)
Landing Leg w/o Gear180 lb (81.6 kg)
Single Wood Deck Board, 360 in. (914.4 cm)140 lb (63.5 kg)
Complete Decking Kit	1,211 lb (549.3 kg)
Steel Stowage Box195 lb (88.5 kg)
Stowage Box Side Panel28 lb (12.7 kg)
Radial Tire96 lb (43.5 kg)
Steel Wheel83 lb (37.6 kg)
Radial Tire and Wheel179 lb (81.2 kg)
Complete Single Point Suspension	1,142 lb (518.0 kg)
Spring Pack (7 leafs)315 lb (142.9 kg)
Dressed Axle Assembly731 lb (331.6 kg)
Air Brake Chamber20 lb (9.1 kg))
Air Reservoir Tank23 lb (10.4 kg)
All Plywood Side Racks, Tarp, and Bows	1,150 lb (521.6 kg)
Side Rack Stake (each)9 lb (4.1 kg)
Bow (each)7 lb (3.2 kg)
Maximum Deck Cargo Weight	45,000 lb (20,412 kg)

END OF WORK PACKAGE

FIELD AND SUSTAINMENT MAINTENANCE**THEORY OF OPERATION**

SEMITRAILER SERIES

The semitrailer is made up of the following systems:

- a. **Electrical System.** Connects to the towing vehicle electrical system to activate the 12 or 24V system. Includes 12 and 24V wiring for operating taillights, clearance lights, and LED lights.
- b. **Brake System.** Air brake system for service and emergency operation. Includes air reservoirs, drain cocks, gladhands, emergency relay valve, multi-function valve, spring brake chambers, lines, fittings, and hoses.
- c. **Service Brake System.** Air pressure activates the air chambers, which push the slack adjusters. The slack adjusters turn the camshafts, causing the brake shoes to expand against the brake drum.
- d. **Suspension System.** Includes springs, U-bolts, axles, and trunnion tube for ease of travel on improved and unimproved roads.

END OF WORK PACKAGE

CHAPTER 2
OPERATOR INSTRUCTIONS

OPERATOR MAINTENANCE**DESCRIPTION AND USE OF OPERATOR'S CONTROLS AND INDICATORS**

CAUTION

- **Fording:** Antilock braking system ECU must not be submerged in water. Rain, sleet, or snow will not affect operation of ECU. Failure to comply may result in damage to equipment.
- **Fording:** Immediately after fording, apply service brakes to expel water from air brake chamber. If fording in salt water, flush chambers with fresh low-pressure water when mission allows. Failure to comply may result in damage to equipment.
- **Fording:** Do not exceed fording depth of 30 in. (76.2 cm) or damage to equipment may result.

NOTE

Light Discipline: For light discipline mission requirements, DO NOT change, remove, or disable the electrical system wiring, lighting, or reflectors. Use duct tape to cover the lens on the ABS warning light and reflectors as needed to meet mission requirements.

LANDING LEGS**WARNING**

Ensure landing leg scissor assemblies retaining (hitch) pins are installed extending inward. If installed extending outward, they will be a contact hazard and may result in injury to personnel.

1. Rotating the crank (Figure 1, Item 3) operates the landing gear.
 - a. Turning the crank (Figure 1, Item 3) clockwise lowers landing legs (Figure 1, Item 5) for parking semitrailer.
 - b. Counterclockwise rotation raises legs (Figure 1, Item 5) to towing position.
2. Pushing operating shaft (Figure 1, Item 2) in engages low speed gear for ease and speed in raising or lowering legs (Figure 1, Item 5).
3. Pulling operating shaft (Figure 1, Item 2) out engages high speed gear for raising or lowering of legs (Figure 1, Item 5).
4. Crank hanger (Figure 1, Item 4) holds the crank (Figure 1, Item 3) when not in use.
5. Scissor shoes (Figure 1, Item 6) keep the leg (Figure 1, Item 5) from sinking into the ground.
6. Landing leg gear box (Figure 1, Item 1) is located on the right side (curbside) of the semitrailer.
7. Ground boards (Figure 1, Item 7) are described in this work package.
8. Retaining pins (Figure 1, Item 8) lock scissor shoes (Figure 1, Item 6) in up or down position.

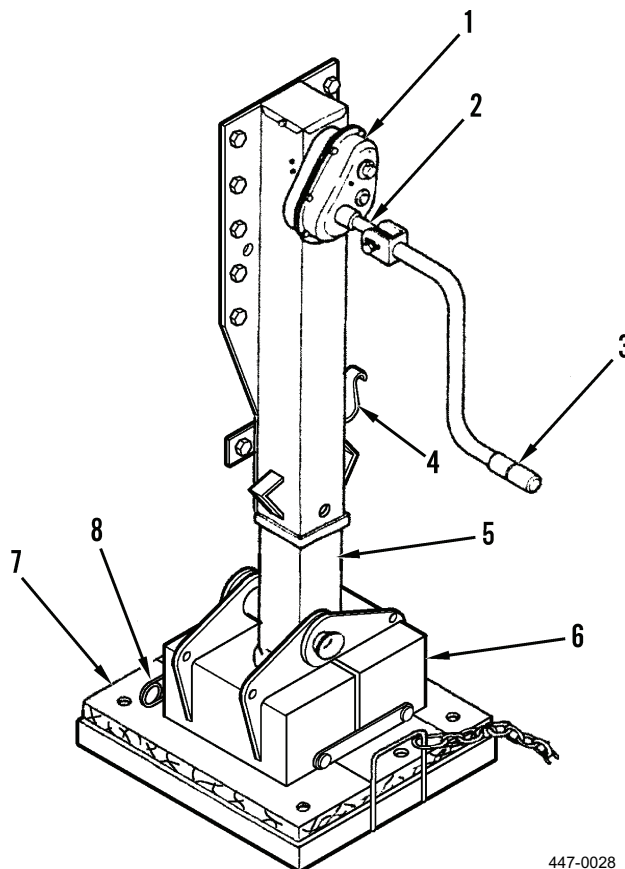

447-0028

Figure 1. Landing Legs.

GROUND BOARDS**WARNING**

Watch hands and fingers when removing/installing ground boards. Hands/fingers could be pinched or cut if not careful when removing/installing ground boards.

1. Two ground boards (Figure 2, Item 1) are provided for placing under landing leg feet to keep them from sinking into soft ground.
2. Stored in brackets (Figure 2, Item 4) welded to frame.
3. Chain (Figure 2, Item 2) is hooked on frame. Snap hook (Figure 2, Item 3) is provided to take up slack in chain (Figure 2, Item 2).
4. As needed, remove ground board (Figure 2, Item 1) for use under axle jack.

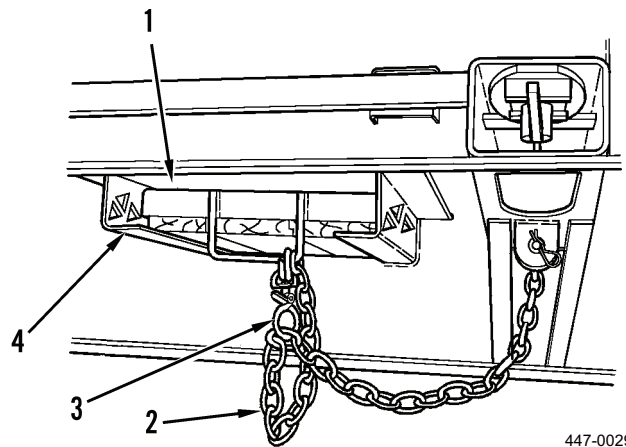

447-0029

Figure 2. Ground Boards.

AIR LINES AND ELECTRICAL CABLES CONNECTIONS

WARNING

Service air is identified by blue markings on gladhand; emergency air is identified by red markings on gladhand. Do not cross service/emergency air lines at gladhands. Make sure they are hooked up correctly to meet brake air pressure requirements. Failure to follow this warning may result in injury to personnel or damage to equipment.

1. Service gladhand (Figure 3, Item 4) and emergency gladhand (Figure 3, Item 1) couplings provide the connection between the semitrailer brake system and the towing vehicle air supply system.
2. Electrical receptacles (Figure 3, Items 2 and 3) provide the connections between the semitrailer lights and the towing vehicle electrical system. Both receptacles use spring-loaded covers to keep foreign matter out when the cables are disconnected. The left (roadside) receptacle (Figure 3, Item 2) is for 12V; the right (curbside) receptacle (Figure 3, Item 3) is for 24V.

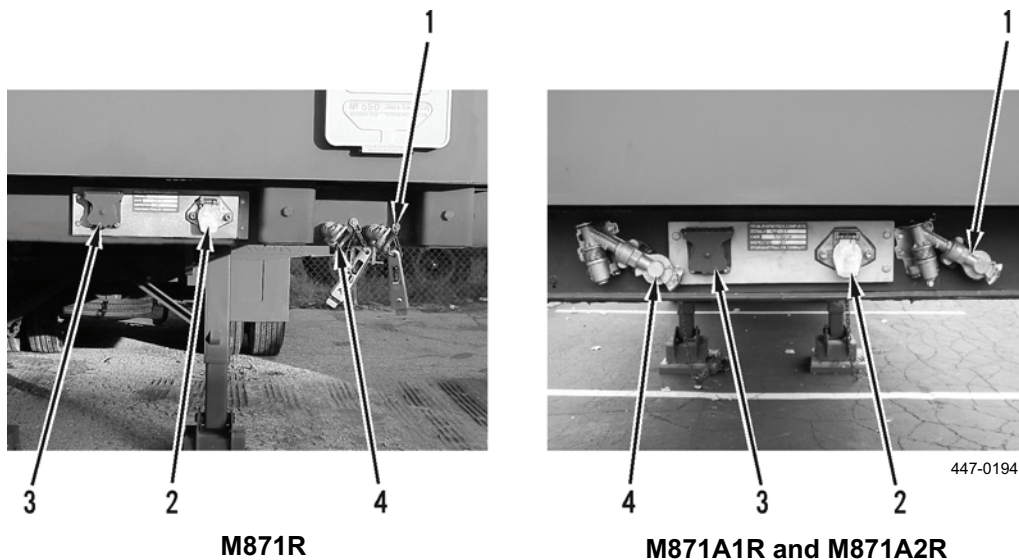
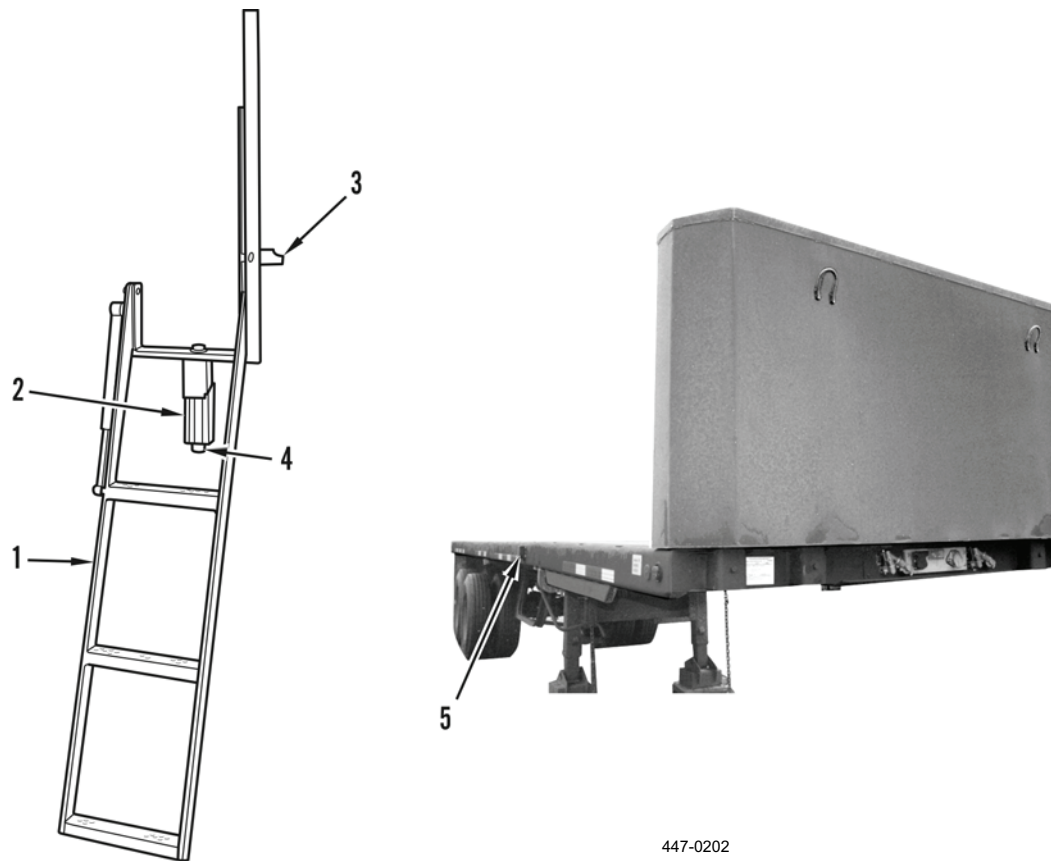

Figure 3. Connections.

LADDER

1. Ladder (Figure 4, Item 1) provides easy access to deck of semitrailer.
2. To install ladder (Figure 4, Item 1), insert stem (Figure 4, Item 2) into bracket (Figure 4, Item 5) and tighten using handle (Figure 4, Item 4).
3. Pull down on lever (Figure 4, Item 3) and lower stairs part of ladder (Figure 4, Item 1).
4. To remove ladder (Figure 4, Item 1), pull down on lever (Figure 4, Item 3) and raise stairs part of ladder.
5. Loosen using handle (Figure 4, Item 4) and remove ladder (Figure 4, Item 1) from bracket (Figure 4, Item 5).

**Figure 4. Ladder.****END OF WORK PACKAGE**

OPERATOR MAINTENANCE**OPERATION UNDER USUAL CONDITIONS****Preparation for Use, Operation, After Use, Slings Procedures**

INITIAL SETUP**Maintenance Level**

Operator

References

WP 0091

Personnel RequiredTwo

PREPARATION FOR USE**WARNING**

- Do not tow M871R, M871A1R, or M871A2R with M52, M52A1, or M52A2 truck tractor. The M52 five-ton truck tractor's inherent design capabilities are not compatible with the semitrailer, and if used, would result in a serious compromise to the safety of personnel and equipment.
- Be sure all personnel stand clear of the towing vehicle and semitrailer during coupling operations. Failure to comply may result in injury or death to personnel.

NOTE

Can be towed by M915 for improved highway use only, or the M818, M931 series, and M932 series for either highway or off-road.

PREPARATION FOR USE - CONTINUED**NOTE**

Reference WP 0091 for more information.

1. Aligning Semitrailer to Towing Vehicle.

- a. Align towing vehicle with semitrailer kingpin (Figure 1, Item 4).
- b. Slowly back towing vehicle into position. Be sure kingpin (Figure 1, Item 4) is in line with fifth wheel coupler jaws (Figure 1, Item 1).
- c. Stop the towing vehicle just before the kingpin plate (Figure 1, Item 3) of the semitrailer starts to ride up the approach ramps (Figure 1, Item 2) of the towing vehicle.

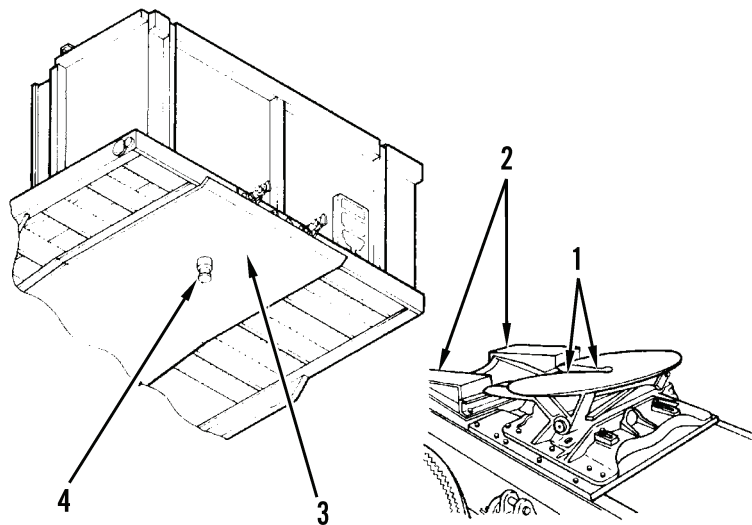

447-0031

Figure 1. Towing Vehicle Alignment.

PREPARATION FOR USE - CONTINUED**2. Connecting Intervehicular Hoses.****WARNING**

Service air is identified by blue markings on gladhand; emergency air is identified by red markings on gladhand. Do not cross service/emergency air lines at gladhands. Make sure they are hooked up correctly to meet brake air pressure requirements. Failure to follow this warning may result in injury to personnel or damage to equipment.

- a. Connect the two air hoses marked SERVICE and EMERGENCY on towing vehicle to corresponding air hose gladhands (Figure 2, Items 1 and 2).
- b. Open air line shut-off valves on towing vehicle.
- c. If no air leakage is detected, apply the brakes on the semitrailer from the towing vehicle.

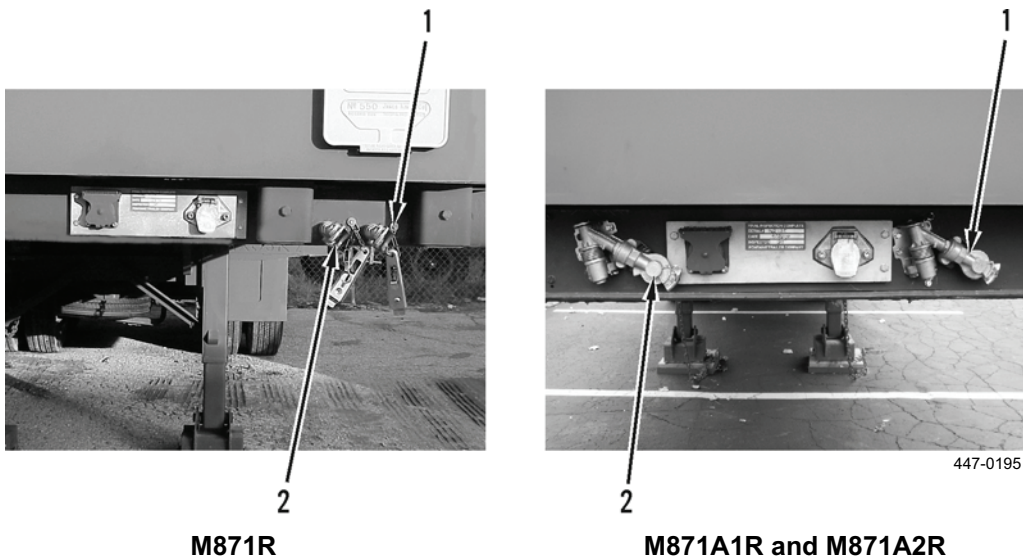

Figure 2. Air Hoses.

PREPARATION FOR USE - CONTINUED**3. Coupling Semitrailer to Towing Vehicle.**

- a. Before kingpin plate (Figure 3, Item 4) starts to ride approach ramps (Figure 3, Item 3), ensure the kingpin plate (Figure 3, Item 4) is above the approach ramps (Figure 3, Item 3). Adjust height as needed by using landing gear. Make sure towing vehicle fifth wheel coupler jaws (Figure 3, Item 2) are open.

WARNING

When towing the semitrailer with M818, M931 series, or M932 series tractors, the fifth wheel wedges must be in the locked-in (pushed-in) mode for highway and secondary road use, and in the locked-out (pulled-out) mode for cross-country operation. Failure to follow this warning may result in injury to personnel or damage to equipment.

- b. Slowly back the towing vehicle until coupler jaws (Figure 3, Item 2) engage kingpin (Figure 3, Item 5).
- c. Visually check the coupling. You should not be able to see light between the fifth wheel (Figure 3, Item 1) and the kingpin plate (Figure 3, Item 4).

CAUTION

If coupling operation is not completed and another attempt is to be made, pull towing vehicle forward carefully. Do not exceed the limits of air hoses and electrical cable. Failure to comply may result in damage to equipment.

- d. Check coupling by carefully inching towing vehicle forward. If coupling is not locked, rock towing vehicle back and forth slowly until kingpin (Figure 3, Item 5) is locked in fifth wheel coupler jaws (Figure 3, Item 2).

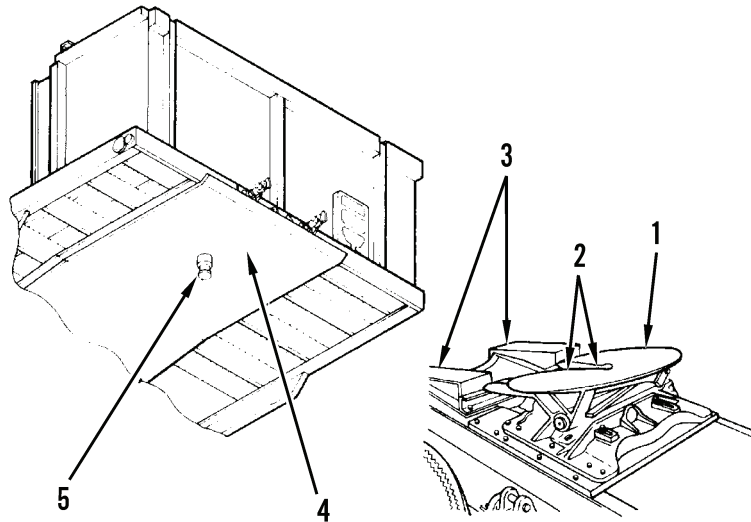

447-0032

Figure 3. Towing Vehicle Coupling.

PREPARATION FOR USE - CONTINUED**4. Connecting Intervehicular Cable.****CAUTION**

The semitrailer's convertor box and electrical system will be damaged if the 12V (7 pin) and 24V (12 pin) cables are plugged in at the same time. Do not plug both the 12V (7 pin) and 24V (12 pin) cables in at the same time. Failure to comply may result in equipment damage.

- a. Open the cover on the receptacle (Figure 4, Item 1 or 2).
- b. Align slot on cable plug with aligning key of receptacle (Figure 4, Item 1 or 2).
- c. Push cable plug into matching receptacle (Figure 4, Items 1 or 2) and release receptacle cover.
- d. Operate lights from towing vehicle to make certain lights are in working order.
- e. Check the air lines and intervehicular cable to ensure they are supported and will not catch or chafe.
- f. Recheck fifth wheel to kingpin locking by trying to move towing vehicle and semitrailer forward.

2
1**M871R**2
1**M871A1R and M871A2R****Figure 4. Cables.**

PREPARATION FOR USE - CONTINUED5. **Raising Landing Gear.****WARNING**

Ensure landing leg scissor assemblies retaining (hitch) pins are installed extending inward. If installed extending outward, they will be a contact hazard and may result in injury to personnel.

- a. Lift crank (Figure 5, Item 1) from crank hanger (Figure 5, Item 2).
- b. Raise crank (Figure 5, Item 1) to operating position. Pull crank out for high speed operation.
- c. Turn crank (Figure 5, Item 1) counterclockwise until legs (Figure 5, Item 3) are retracted fully.
- d. Lower crank (Figure 5, Item 1) and secure in crank hanger (Figure 5, Item 2).
- e. Remove and stow ground boards (Figure 5, Item 4), if used.

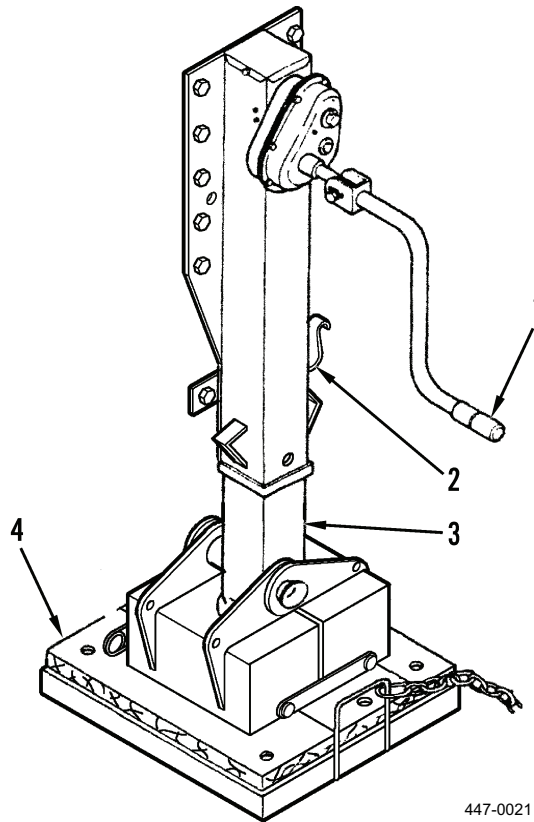

Figure 5. Landing Legs.

PREPARATION FOR USE - CONTINUED**6. Stowing Ground Boards.****WARNING**

Watch hands and fingers when removing/installing ground boards. Fingers/hands could be pinched or cut if not careful when removing/installing ground boards.

- a. Position ground board (Figure 6, Item 1) in brackets (Figure 6, Item 2) with handle (Figure 6, Item 6) down.
- b. Connect center snap hook (Figure 6, Item 5) to S-hook (Figure 6, Item 3).
- c. At storage box side (roadside) of semitrailer, connect end snap hook (Figure 6, Item 4) to S-hook (Figure 6, Item 3).

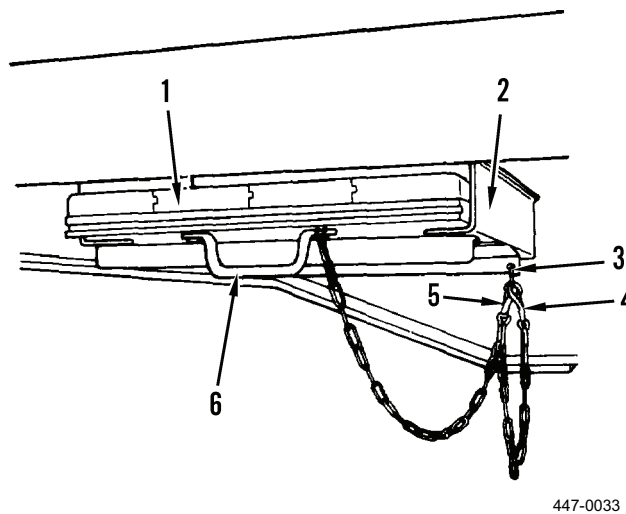

Figure 6. Ground Boards.

OPERATION1. **Loading Semitrailer (Containerized Cargo) (M871R and M871A1R).****WARNING**

Do not place any part of your body under a container during the loading or unloading operation. Container may crush, pinch, or pin any body part that is under a container. Failure to comply may result in injury to personnel.

- a. Release handle (Figure 7, Item 3) from latch (Figure 7, Item 2). Push twist lock (Figure 7, Item 1) up.
- b. Turn handle (Figure 7, Item 3) clockwise 90 degrees to rotate twist lock bayonet (Figure 7, Item 4) into loading position.
- c. Repeat steps (1a and 1b) for three remaining twist locks.
- d. Load cargo container on the semitrailer.
- e. Check mating of twist lock bayonets (Figure 7, Item 4) and container fittings.
- f. Turn handle (Figure 7, Item 3) clockwise 90 degrees to rotate twist lock bayonet (Figure 7, Item 4) into locked position.
- g. Secure handle (Figure 7, Item 3) with latch (Figure 7, Item 2).
- h. Repeat steps (1f and 1g) for three remaining twist locks.

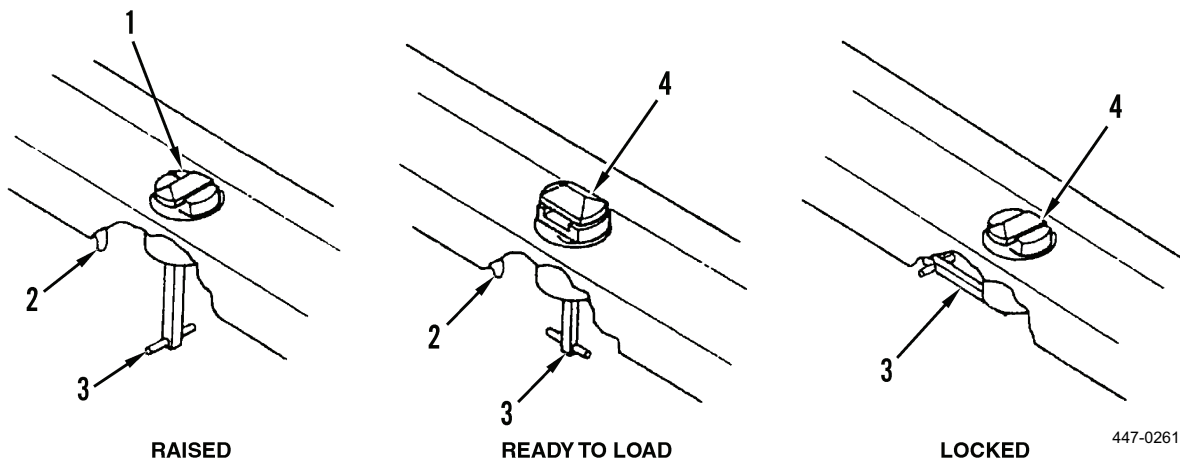

Figure 7. Twist Lock Operation (M871R and M871A1R).

WARNING

- Do not tow the semitrailer with an unsecured cargo container. Accident may occur resulting in injury to personnel.
 - When transporting the 8-1/2 ft commercial container, the towing vehicle fifth wheel height must not exceed 50.4 in. (1.28 m) to comply with the 157.48 in. (4 m) overall height limit for USAREUR. The M915 fifth wheel height meets this requirement. Failure to follow this warning may result in injury to personnel or damage to equipment.
- i. Visually check to ensure container is securely locked.

OPERATION - CONTINUED**2. Loading Semitrailer (Containerized Cargo) (M871A2R).****WARNING**

Do not place any part of your body under a container during the loading or unloading operation. Container may crush, pinch, or pin any body part that is under a container. Failure to comply may result in injury to personnel.

- a. Pull elastic strap (Figure 8, Item 3) from eye bolt (Figure 8, Item 4) and lower handle (Figure 8, Item 2). Push twist lock (Figure 8, Item 1) up.
- b. Turn handle (Figure 8, Item 2) 90 degrees to rotate twist lock bayonet (Figure 8, Item 5) into loading position.
- c. Repeat steps (2a and 2b) for three remaining twist locks.
- d. Load cargo container on the semitrailer.
- e. Check mating of twist lock bayonets (Figure 8, Item 5) and container fittings.
- f. Turn handle (Figure 8, Item 2) 90 degrees to rotate twist lock bayonet (Figure 8, Item 5) into locked position.
- g. Raise handle (Figure 8, Item 2) and secure elastic strap (Figure 8, Item 3) in eye bolt (Figure 8, Item 4).
- h. Repeat steps (2f and 2g) for three remaining twist locks.

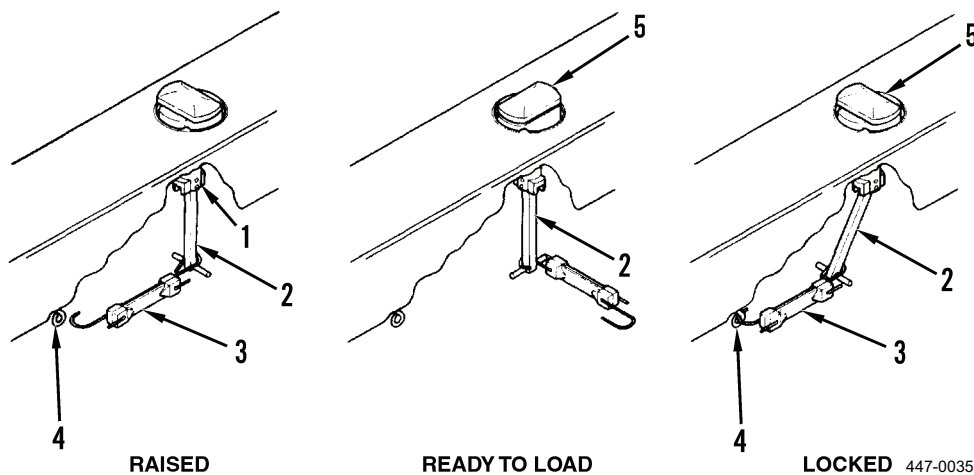

Figure 8. Twist Lock Operation (M871A2R).

WARNING

- Do not tow the semitrailer with an unsecured cargo container. Accident may occur resulting in injury to personnel.
 - When transporting the 8-1/2 ft commercial container, the towing vehicle fifth wheel height must not exceed 50.4 in. (1.28 m) to comply with the 157.48 in. (4 m) overall height limit for USAREUR. The M915 fifth wheel height meets this requirement. Failure to follow this warning may result in injury to personnel or damage to equipment.
- i. Visually check to ensure container is securely locked.

OPERATION - CONTINUED

3. **Towing Semitrailer.**

WARNING

- When towing the semitrailer with M818, M931 series, or M932 series tractors, the fifth wheel wedges must be in the locked-in (pushed-in) mode for highway and secondary road use, and in the locked-out (pulled-out) mode for cross-country operation.
 - Extreme caution must be exercised in all turns, curves, and highway cloverleaves when towing a high center of gravity containerized load as containerized load may fall off of trailer.
 - Under no circumstances shall speeds exceed the following:

Highway	55 mph (89 kph)
Secondary	35 mph (56 kph)
Trails	15 mph (24 kph)
Rough	10 mph (16 kph)
 - Failure to observe these warnings may result in injury to personnel or damage to equipment.
- a. **Driving.** When driving the towing vehicle and semitrailer, the overall length of the unit must be kept in mind when passing other vehicles and when turning. Because the unit is hinged in the middle, backing is also affected. The semitrailer’s payload will affect stopping and off-road maneuverability.
 - b. **Turning.** When turning corners, allow for the semitrailer wheels turning inside the radius of the towing vehicle. Make a right turn by driving the towing vehicle about halfway into the intersection, then cutting sharply to the right. This will keep the semitrailer off the curb.

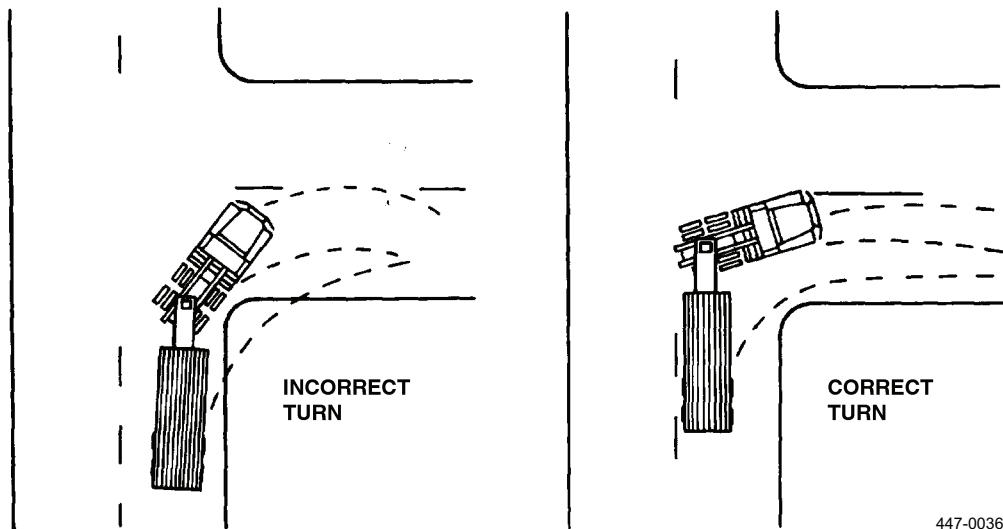

Figure 9. Turning.

447-0036

- c. **Stopping.** The brakes of the towing vehicle and the semitrailer are applied at the same time in normal operation when the driver steps on the brake pedal. Brake pressure should be applied gradually and smoothly. The semitrailer brakes may be applied separately by using the trailer handbrake control lever on the steering column. On steep downgrades or slippery surfaces, slowly apply the semitrailer brakes using the trailer handbrake control lever before you apply the towing vehicle brakes. This will reduce the possibility of jackknifing the semitrailer.

OPERATION - CONTINUED

- d. **Parking.** When the towing vehicle and the semitrailer are to be parked and left unattended, set the parking brake on the towing vehicle and apply the brakes on the semitrailer. Turn off the towing vehicle's engine before leaving the cab. Block the semitrailer wheels with wheel chocks.
- e. **Backing.** When backing, use a helper as a ground guide to direct you. Adjust rear-view mirrors before backing. When backing, the rear of the semitrailer will move in the opposite direction from the towing vehicle's front wheels. If the wheels are turned to the right, the semitrailer will go left. If the wheels are turned left, the semitrailer will go right.

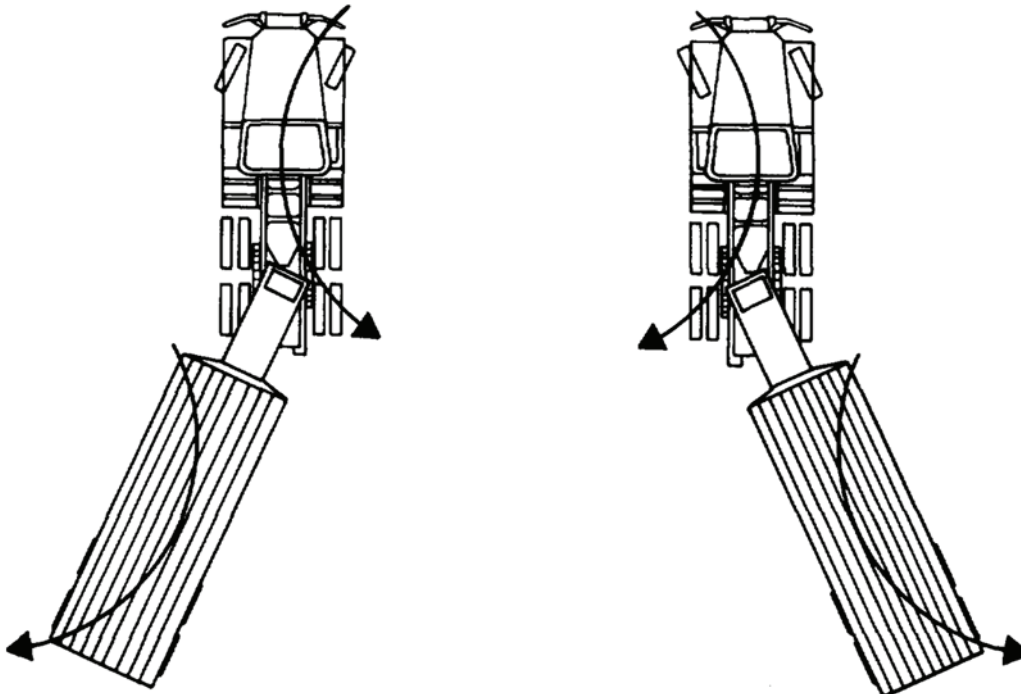

447-0037

Figure 10. Backing.

OPERATION - CONTINUED**4. Unloading Semitrailer (Containerized Cargo) (M871A2R).****WARNING**

Do not place any part of your body under a container during the loading or unloading operation. Container may crush, pinch, or pin any body part that is under a container. Failure to comply may result in injury to personnel.

- a. Pull elastic strap (Figure 11, Item 3) from eye bolt (Figure 11, Item 4).
- b. Turn handle (Figure 11, Item 2) 90 degrees to rotate twist lock bayonet (Figure 11, Item 5) to unloading position.
- c. Repeat steps (4a and 4b) for three remaining twist locks.
- d. Unload cargo container from semitrailer.
- e. Turn handle (Figure 11, Item 2) 90 degrees and lower twist lock assembly (Figure 11, Item 1) to stowed position.
- f. Raise handle (Figure 11, Item 2) and secure elastic strap (Figure 11, Item 3) in eye bolt (Figure 11, Item 4).
- g. Repeat steps (4e and 4f) for three remaining twist locks.

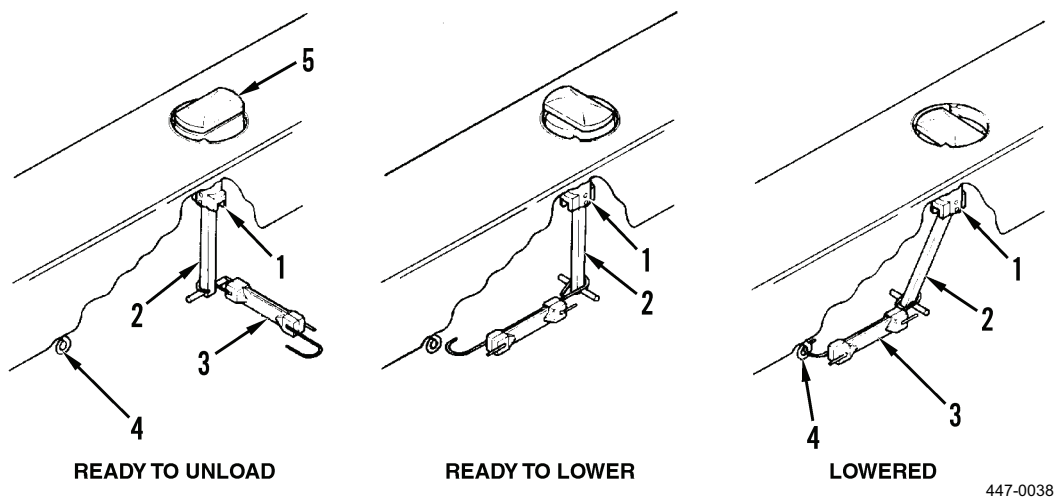
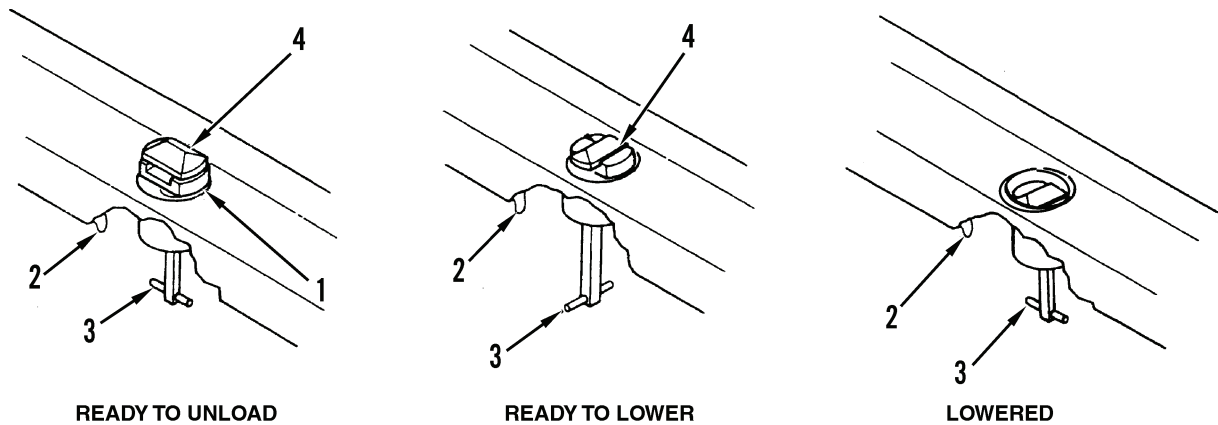

Figure 11. Twist Lock Operation (M871A2R).

OPERATION - CONTINUED**5. Unloading Semitrailer (Containerized Cargo) (M871R and M871A1R).****WARNING**

Do not place any part of your body under a container during the loading or unloading operation. Container may crush, pinch, or pin any body part that is under a container. Failure to comply may result in injury to personnel.

- a. Release handle (Figure 12, Item 3) from latch (Figure 12, Item 2).
- b. Turn handle (Figure 12, Item 3) counterclockwise 90 degrees to rotate twist lock bayonet (Figure 12, Item 4).
- c. Repeat steps (5a and 5b) for three remaining twist locks.
- d. Unload cargo container from the semitrailer.
- e. Turn handle (Figure 12, Item 3) counterclockwise 90 degrees and lower twist lock (Figure 7, Item 1).
- f. Secure handle (Figure 12, Item 3) to latch (Figure 12, Item 2).
- g. Repeat steps (5e and 5f) for three remaining twist locks.



447-0262

Figure 12. Twist Lock Operation (M871R and M871A1R).

AFTER USE1. **Lowering Landing Gear.****WARNING**

- Ensure landing leg scissor assemblies retaining (hitch) pins are installed extending inward. If installed extending outward, they will be a contact hazard and may result in injury to personnel.
- Watch hands and fingers when removing/installing ground boards. Fingers/hands could be pinched or cut if not careful when removing/installing ground boards.

NOTE

Park semitrailer with bulkhead end slightly elevated to allow any water to run off.

- a. If ground is soft, position ground boards (Figure 13, Item 4) under sand shoes of legs (Figure 13, Item 3).
- b. Lift crank (Figure 13, Item 1) from crank hanger (Figure 13, Item 2).
- c. Raise crank (Figure 13, Item 1) to operating position. Push crank in for low speed operation.
- d. Turn crank (Figure 13, Item 1) clockwise until legs (Figure 13, Item 3) are extended.
- e. Lower crank (Figure 13, Item 1) and secure in crank hanger (Figure 13, Item 2).

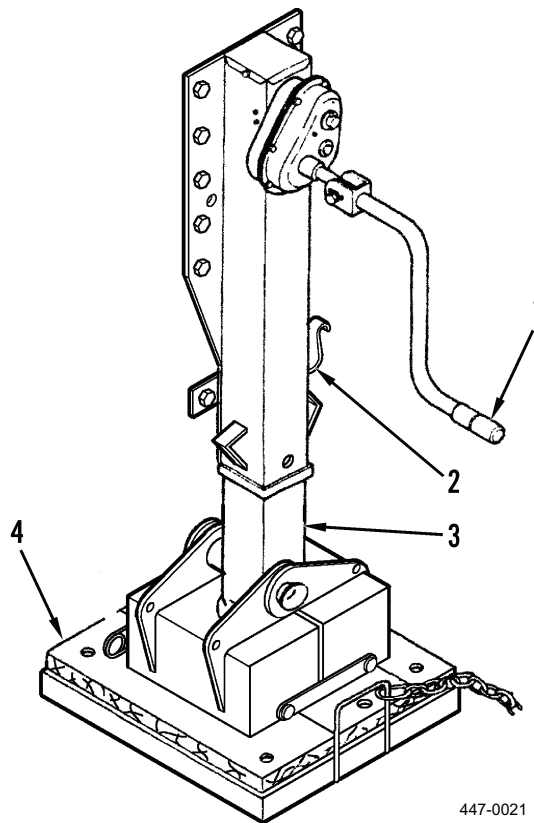
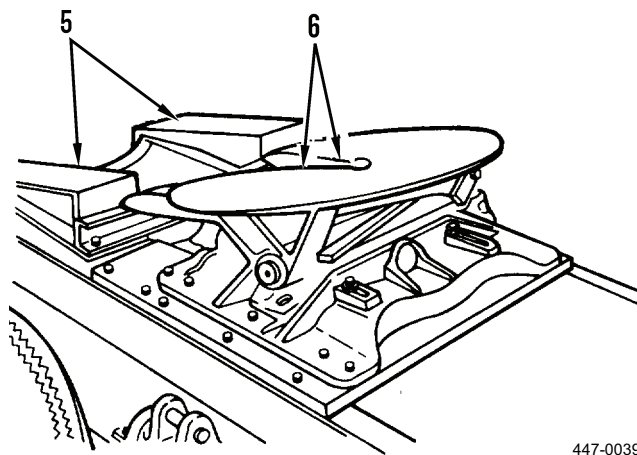
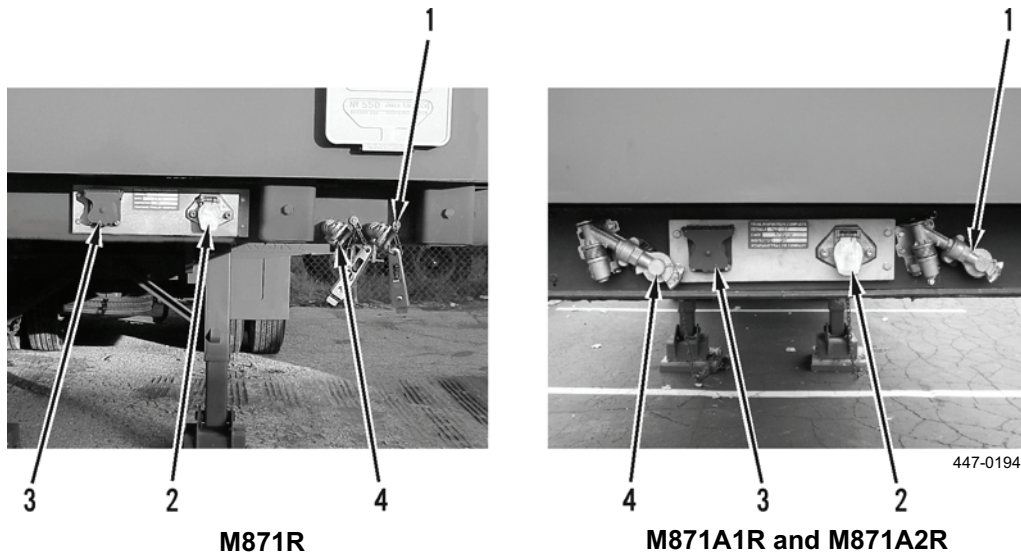

Figure 13. Landing Legs.

AFTER USE - CONTINUED**2. Uncoupling Semitrailer from Towing Vehicle.**

- a. At towing vehicle, close the air line shut-off valves.
- b. Disconnect the two air hoses from the air hose gladhands (Figure 14, Items 1 and 4) on the semitrailer.
- c. Open cover on receptacle (Figure 14, Item 2 or 3), pull intervehicular cable plug from receptacle, and release cover.
- d. At towing vehicle, open fifth wheel coupler jaws (Figure 14, Item 6) to release semitrailer kingpin.
- e. Slowly drive towing vehicle forward until semitrailer is clear of approach ramps (Figure 14, Item 5).

**Figure 14. Uncoupling Trailer.****END OF TASK**

SLINGING PROCEDURES**CAUTION**

Do not lift the semitrailer with tarps, side racks, and ladder installed. This will damage tarps, side racks, stakes, and ladder.

NOTE

Tarps, bows, side racks, and ladder should be stowed prior to lifting.

1. Remove and stow tarps, side racks, stakes, and ladder.
2. Stow ground boards and wheel chocks.

CAUTION

Be sure that the sling hook point is facing toward the outside of the semitrailer or damage to equipment could result.

3. Connect sling hooks to the four lift points (Figure 15, Item 1).

WARNING

- Do not get under semitrailer while slinging operations are underway. Do not lift a loaded semitrailer. Failure to observe this warning could result in serious injury or death to personnel and damage to equipment.
 - Do not lift the semitrailer without a ground guide, using a 30 ft (9 m) guideline attached to one rear lift point (Figure 15, Item 1). Lack of ground guide steering assistance could result in serious injury or death to personnel and damage to equipment.
4. Slowly take up all slack, then lift semitrailer.
 5. After loading the semitrailer, remove the sling hooks from four lift points (Figure 15, Item 1).

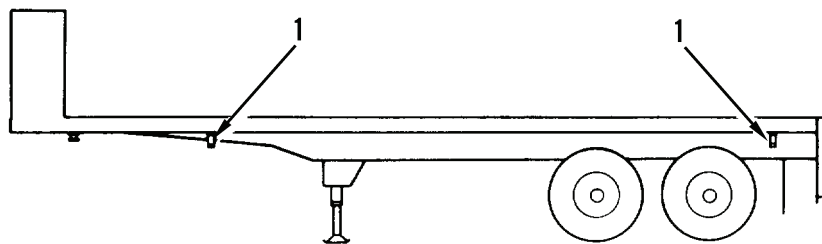

447-0040

Figure 15. Lift Points.

END OF TASK

END OF WORK PACKAGE

OPERATOR MAINTENANCE
OPERATION UNDER UNUSUAL CONDITIONS

**Extreme Cold, Extreme Heat, Rainy or Humid Conditions,
Salt Water Areas, Snow, Mud or Sand,
Rocky Terrain, Fording**

INITIAL SETUP
Maintenance Level

Operator

References

FM 9-207

References - Continued

FM 21-305

FM 90-3

TB 43-0239

WP 0018

WP 0067

EXTREME COLD
1. Startup.

- a. Be careful when placing the semitrailer in motion after a shutdown. Congealed lubricants can cause part failure.
- b. Tires and ground boards may freeze to the ground or tire flat spotting may occur if tires are underinflated.
- c. Brake shoes may freeze to the brake drums and need to be heated to prevent damage to mating surfaces.
- d. Refer to FM 9-207 and FM 21-305 for special instructions on driving hazards in snow and ice that may be encountered during extreme cold weather conditions.

2. Shutdown.

- a. For short periods, park in a sheltered spot out of the wind; for longer shutdown periods, if high, dry ground is not available, prepare a footing of planks or brush.
- b. Remove all buildup of ice and snow as soon as possible after shutdown.
- c. Cover and shield the semitrailer with canvas covers if available. Keep the ends of covers off the ground to keep them from freezing to the ground. Drain air/moisture from air reservoirs (WP 0018).

END OF TASK
EXTREME HEAT

1. Refer to TB 43-0239 and FM 90-3 for maintenance and operations, respectively, under desert conditions.
2. Do not park the semitrailer in the sun for long periods of time. Heat and sunlight shorten the life of tires.
3. Park the semitrailer where it will get maximum protection from heat, sun, and dust.

END OF TASK
RAINY OR HUMID CONDITIONS

Frequently inspect, clean, and lubricate inactive equipment to prevent rust and fungus accumulation.

END OF TASK
SALT WATER AREAS

Salt water will cause rapid corrosion of metal parts. After operation, wash the semitrailer with fresh water. Clean, inspect, and lubricate equipment frequently.

END OF TASK

SNOW

Refer to FM 21-305 for special instructions on operation in snow.

END OF TASK**MUD OR SAND****CAUTION**

Do not tow, pull, push, or lift semitrailer using rear bumper. This may damage equipment.

1. If wheels sink into mud/sand, you may need to jack up the mired wheels and put planking or matting under them.
2. After operation in mud or sand, clean, inspect, and lubricate the semitrailer.

END OF TASK**ROCKY TERRAIN**

1. Before driving over stumps or rocks, make sure the semitrailer can clear them. Such objects can damage parts on the underside of the semitrailer. Beware of low hanging tree limbs that can damage cargo.
2. Be sure you have a serviceable spare tire because there is a greater chance of tire puncture.

END OF TASK**FORDING**

1. **Before Fording.**

CAUTION

- **Fording:** Antilock braking system ECU must not be submerged in water. Rain, sleet, or snow will not affect operation of ECU. Failure to comply may result in damage to equipment.
 - **Fording:** Immediately after fording, apply service brakes to expel water from air brake chamber. If fording in salt water, flush chambers with fresh low-pressure water when mission allows. Failure to comply may result in damage to equipment.
 - **Fording:** Do not exceed fording depth of 30 in. (76.2 cm) or damage to equipment may result.
- a. Before entering water, check bottom surface conditions. If bottom surface is too soft, do not ford.
 - b. Protect cables and terminals by spraying with ignition insulation compound.
 - c. ABS ECU must not be submerged in water (42 in. [106.7 cm], ECU height).
2. **After Fording.**
 - a. After coming out of water, apply brakes a few times to help dry out brake linings. Make sure semitrailer brakes are working before driving at normal speeds.
 - b. Drain or dry all areas where water has collected, if mission allows.
 - c. Lubricate all unpainted surfaces. See lubrication chart, WP 0067, if mission allows.
 - d. Zerk fittings and hubs should not be affected by fording. Oil can points should be lubricated as specified by WP 0067, if mission allows. There is no need to tear down wheel ends or clean and re-pack bearings.

END OF TASK**END OF WORK PACKAGE**

CHAPTER 3
OPERATOR TROUBLESHOOTING PROCEDURES

OPERATOR MAINTENANCE

OPERATOR TROUBLESHOOTING INTRODUCTION

1. This chapter provides information for identifying and correcting malfunctions using Operator Troubleshooting.
2. The *Operator Troubleshooting Symptom Index* in WP 0008 lists common malfunctions which may occur and refers you to the proper page in WP 0009 for a troubleshooting procedure.
3. If you are unsure of the location of an item mentioned in troubleshooting, refer to WP 0002 or WP 0004.
4. Before performing troubleshooting, read and follow all safety instructions found in the *Warning Summary* at the front of this manual.
5. The *Operator Troubleshooting Symptom Index* cannot list all malfunctions that may occur, nor all tests or inspections and corrective actions. If a malfunction is not listed, or is not corrected by the listed corrective actions, notify your supervisor.
6. When troubleshooting a malfunction:
 - a. Locate the symptom or symptoms in WP 0008 that best describe the malfunction.
 - b. Turn to the page in WP 0009 where the troubleshooting procedures for the malfunction in question are described. Headings at the top of each page show how each troubleshooting procedure is organized: MALFUNCTION, TEST OR INSPECTION (in step number order), and CORRECTIVE ACTION.
 - c. Perform each step in the order listed until the malfunction is corrected. DO NOT perform any maintenance task unless the troubleshooting procedure tells you to do so.

EXPLANATION OF HEADINGS

The headings in WP 0009 are defined as follows:

1. **MALFUNCTION**. A visual or operational indication that something is wrong with the equipment.
2. **TEST OR INSPECTION**. A procedure to isolate the problem in a system or component.
3. **CORRECTIVE ACTION**. A procedure to correct the problem.

END OF WORK PACKAGE

OPERATOR MAINTENANCE

OPERATOR TROUBLESHOOTING SYMPTOM INDEX

SYMPTOM	PAGE NO.
ELECTRICAL SYSTEM	
All Lights Do Not Light.	0009-1
One or More Lights Will Not Light.	0009-1
Dim or Flickering Lights.	0009-2
BRAKES	
Brakes Will Not Release.	0009-2
Grabbing Brakes.	0009-3
LANDING GEAR	
Landing Gear is Difficult to Raise or Lower.	0009-4
TIRES	
Excessively Worn, Scuffed, or Cupped Tires.	0009-4
END OF WORK PACKAGE	

OPERATOR MAINTENANCE
OPERATOR TROUBLESHOOTING PROCEDURES
Electrical System, Brakes, Landing Gear, Tires

MALFUNCTION
TEST OR INSPECTION
CORRECTIVE ACTION

ELECTRICAL SYSTEM

1. ALL LIGHTS DO NOT LIGHT.

WARNING

Disconnect electrical power source before performing any troubleshooting on wiring harness, connectors, or lights. Failure to comply could result in injury to personnel.

- Step 1. Turn on towing vehicle lights, including turn signal lights, and stop. (See operator's manual for towing vehicle.)
- a. If towing vehicle lights do not light, notify Organizational Maintenance.
 - b. If towing vehicle lights come on, go to step 2.
- Step 2. Check electrical connection at intervehicular cable receptacle.
- a. If cable is not properly connected, reconnect electrical cable.
 - b. If cable is properly connected, go to step 3.
- Step 3. Check intervehicular connectors for dirty, damaged, or corroded pins.
- a. If pins are dirty or corroded, clean the pins (WP 0017).
 - b. If pins are damaged, notify Organizational Maintenance.
 - c. If the above steps do not correct the malfunction, notify Organizational Maintenance.

2. ONE OR MORE LIGHTS WILL NOT LIGHT.

- Step 1. Check for burned out or defective LEDs.
- a. If LEDs are burned out or defective, notify Organizational Maintenance.
 - b. If LEDs are not burned out or defective, go to step 2.
- Step 2. Check for dirty or corroded connectors at back of light.
- a. If connectors are dirty or corroded, clean them (WP 0017).
 - b. If connectors are not dirty or corroded, go to step 3.
- Step 3. Check for broken lead wires or loose connections.
- a. If lead wires are broken, notify Organizational Maintenance.
 - b. If connections are not loose or broken, go to step 4.

MALFUNCTION
TEST OR INSPECTION
CORRECTIVE ACTION

ELECTRICAL SYSTEM - CONTINUED**2. ONE OR MORE LIGHTS WILL NOT LIGHT - CONTINUED.**

- Step 4. Check light assembly for damage.
- If light assembly is damaged, notify Organizational Maintenance.
 - If light assembly is not damaged and malfunction is not corrected, notify Organizational Maintenance.

3. DIM OR FLICKERING LIGHTS.

- Step 1. Check electrical connectors at light for loose, dirty, or corroded pins.
- If connectors are loose, tighten.
 - If connector pins are dirty or corroded, clean pins (WP 0017).
 - If connectors are tight and clean, go to step 2.
- Step 2. Check for defective LEDs.
- If LEDs are defective, notify Organizational Maintenance.
 - If LEDs are not defective, go to step 3.
- Step 3. Check intervehicular connectors for dirty, damaged, or corroded pins.
- If pins are dirty or corroded, clean the pins (WP 0017).
 - If pins are damaged, notify Organizational Maintenance.
 - If the above steps do not correct the malfunction, notify Organizational Maintenance.

NOTE

To troubleshoot ABS, refer to WP 0089, Figure 3.

BRAKES**4. BRAKES WILL NOT RELEASE.**

- Step 1. If towing vehicle is equipped with air line shut-off valves at the gladhands, check to make sure they are fully open. (See operator's manual for towing vehicle.)
- If air line valves are shut off, open them fully.
 - If air supply is on, go to step 2.
 - If towing vehicle is not equipped with shut-off valves, go to step 2.
- Step 2. Check pressure gage in towing vehicle for a minimum of 90 psi (621 kPa).
- If pressure is low, build up air pressure to normal level.
 - If pressure is low and will not build up, notify Organizational Maintenance.
 - If pressure is normal, go to step 3.

MALFUNCTION
TEST OR INSPECTION
CORRECTIVE ACTION

BRAKES - CONTINUED**4. BRAKES WILL NOT RELEASE - CONTINUED.**

- Step 3. Check pressure gage in towing vehicle for a minimum of 90 psi (621 kPa).
- If pressure is low, build up air pressure to normal level.
 - If pressure is low and will not build up, notify Organizational Maintenance.
 - If pressure is normal, go to step 3.
- Step 4. Check air line connections at gladhands.
- If air lines are not properly connected (Emergency to Emergency, Service to Service), reconnect gladhands.
 - If air lines are connected properly, go to step 4.
- Step 5. Check for dirty or damaged packing in gladhands.
- If packing is dirty, clean packing (WP 0019).
 - If packing is leaking or missing, notify Organizational Maintenance.
 - If packing is clean and not damaged, go to step 5.
- Step 6. Inspect air line connections for leaks.
- If leaks are evident, notify Organizational Maintenance.
 - If no leaks are evident, go to step 6.
- Step 7. Check drain cock on each reservoir if stuck open.
- If either drain cock is stuck open, notify Organizational Maintenance.
 - If drain cocks are working properly, notify Organizational Maintenance.

5. GRABBING BRAKES.**WARNING**

Wear protective goggles when opening drain cock and avoid the air stream. Failure to comply could result in injury to personnel.

Check for moisture in air reservoir by opening each drain cock (WP 0018).

- If moisture is present, allow to drain.
- If reservoirs are dry and malfunction is not corrected, notify Organizational Maintenance.

MALFUNCTION
TEST OR INSPECTION
CORRECTIVE ACTION

LANDING GEAR**6. LANDING GEAR IS DIFFICULT TO RAISE OR LOWER.**

- Step 1. Check for misaligned or broken crank handle.
- If handle is misaligned or broken, notify Organizational Maintenance.
 - If handle is not misaligned or broken, go to step 2.
- Step 2. Check for dirt on lower landing gear leg.
- If lower landing gear leg is dirty, clean leg (WP 0020).
 - If lower landing gear leg is clean, go to step 3.
- Step 3. Check for misaligned, damaged, or bent landing legs.
- If legs are misaligned, damaged, or bent, notify Organizational Maintenance.

TIRES**7. EXCESSIVELY WORN, SCUFFED, OR CUPPED TIRES.**

- Step 1. Check that cold tire pressure is 115 psi (793 kPa).
- If tire pressure is incorrect, inflate or deflate tires to correct pressure.
 - If tire pressure is correct, go to step 2.
- Step 2. Check for loose, cracked, or broken wheels.
- If wheels are loose, tighten nuts.
 - If wheel is cracked or broken, notify Organizational Maintenance.
 - If wheel is secure and not cracked or broken, go to step 3.
- Step 3. Check suspension system for damaged springs and loose or missing bolts and nuts.
- If suspension system is damaged or has loose or missing bolts and nuts, notify Organizational Maintenance.
 - If suspension system is not damaged and all hardware is complete and secure, go to step 4.
- Step 4. Check tracking for indication of axle misalignment.
- If axle appears to be misaligned, notify Organizational Maintenance.
 - If the above steps do not correct the malfunction, notify Organizational Maintenance.

END OF WORK PACKAGE

CHAPTER 4
ORGANIZATIONAL TROUBLESHOOTING PROCEDURES

ORGANIZATIONAL MAINTENANCE**ORGANIZATIONAL TROUBLESHOOTING INTRODUCTION**

1. This chapter provides information for identifying and correcting malfunctions using Organizational Troubleshooting.
2. The *Organizational Troubleshooting Symptom Index* in WP 0011 lists common malfunctions which may occur and refers you to the proper page in WP 0012 for a troubleshooting procedure.
3. If you are unsure of the location of an item mentioned in troubleshooting, refer to WP 0002 or WP 0004.
4. Before performing troubleshooting, read and follow all safety instructions found in the *Warning Summary* at the front of this manual.
5. The *Organizational Troubleshooting Symptom Index* cannot list all malfunctions that may occur, nor all tests or inspections and corrective actions. If a malfunction is not listed, or is not corrected by the listed corrective actions, notify your supervisor.
6. When troubleshooting a malfunction:
 - a. Locate the symptom or symptoms in WP 0011 that best describe the malfunction.
 - b. Turn to the page in WP 0012 where the troubleshooting procedures for the malfunction in question are described. Headings at the top of each page show how each troubleshooting procedure is organized: MALFUNCTION, TEST OR INSPECTION (in step number order), and CORRECTIVE ACTION.
 - c. Perform each step in the order listed until the malfunction is corrected. DO NOT perform any maintenance task unless the troubleshooting procedure tells you to do so.

EXPLANATION OF HEADINGS

The headings in WP 0012 are defined as follows:

1. **MALFUNCTION**. A visual or operational indication that something is wrong with the equipment.
2. **TEST OR INSPECTION**. A procedure to isolate the problem in a system or component.
3. **CORRECTIVE ACTION**. A procedure to correct the problem.

END OF WORK PACKAGE

ORGANIZATIONAL MAINTENANCE
ORGANIZATIONAL TROUBLESHOOTING SYMPTOM INDEX

SYMPTOM	PAGE NO.
ELECTRICAL SYSTEM	
All Lights Do Not Light.	0012-1
One or More Lights Will Not Light.	0012-1
BRAKES	
Brakes Will Not Release.	0012-2
No Brakes or Weak Brakes.	0012-3
Slow Brake Application or Release.	0012-5
Grabbing Brakes.	0012-6
Brakes Drag and One or More Brake Drums Running Hot.	0012-7
Hard Pulling.	0012-8
LANDING GEAR	
Difficulty in Turning Handcrank.	0012-8
SPRINGS AND SUSPENSION	
Improper Spring Action.	0012-9
TIRES AND WHEELS	
Excessively Worn, Scuffed, or Cupped Tires.	0012-9
END OF WORK PACKAGE	

ORGANIZATIONAL MAINTENANCE
ORGANIZATIONAL TROUBLESHOOTING PROCEDURES
Electrical System, Brakes, Landing Gear, Springs and Suspension, Tires and Wheels

MALFUNCTION
TEST OR INSPECTION
CORRECTIVE ACTION

ELECTRICAL SYSTEM

WARNING

Disconnect electrical power source before performing any troubleshooting on wiring harness, connectors, or lights. Failure to comply could result in injury to personnel.

1. ALL LIGHTS DO NOT LIGHT.

- Step 1. Check towing vehicle for power. (See operator's manual for towing vehicle.)
- a. Check towing vehicle TM for power source to convertor box or vehicular cable; if no power, notify Organizational Maintenance.
 - b. Set light switch properly. If there is no power, notify Organizational Maintenance.
 - c. If there is power, go to step 2.
- Step 2. Check intervehicular cable receptacles for proper connections.
- a. Pull plug out and reinsert fully.
 - b. If receptacles are not defective, go to step 3.
- Step 3. Check towing vehicle for tripped circuit breakers or blown fuses. (See maintenance manual for towing vehicle.)
- a. If circuit breaker is open, reset circuit breaker.
 - b. If fuse is blown, replace fuse.
 - c. If circuit breaker is not tripped and fuse is not blown, go to step 4.
- Step 4. Check wiring for bare spots in insulation.
- a. Repair wiring, if defective (WP 0024).
 - b. If wiring is not defective, go to step 5.
- Step 5. Remove nose plate (WP 0029) and check for loose or broken ground wires. Repair ground wire or tighten connection. Install nose plate.

2. ONE OR MORE LIGHTS WILL NOT LIGHT.

- Step 1. Check for burned out LED.
- a. Replace LED, if defective (WP 0027).
 - b. If LED does not light, go to step 2.
- Step 2. Remove LED and check socket for dirt or corrosion.
- a. Clean socket, if dirty or corroded.
 - b. If socket is clean, install LED and go to step 3.

MALFUNCTION
TEST OR INSPECTION
CORRECTIVE ACTION

ELECTRICAL SYSTEM - CONTINUED

2. ONE OR MORE LIGHTS WILL NOT LIGHT - CONTINUED.

- Step 3. Check for damaged LED light assembly.
 - a. Replace light assembly, if damaged (WP 0025 thru WP 0027).
 - b. If light assembly is not damaged, go to step 4.
- Step 4. Check plug and/or receptacle for dirty or corroded contacts.
 - a. Clean contacts, if dirty or corroded.
 - b. If contacts are not dirty or corroded, go to step 5.
- Step 5. Check for broken or shorted wire in cable or loose connection in plug or receptacle.
 - a. Tighten, repair, or replace as necessary.
 - b. If wiring and connections are not damaged, go to step 6.
- Step 6. Remove nose plate (WP 0029) and check for loose or broken ground wire.
 - a. If ground wire is broken, repair or replace wire and install nose plate.
 - b. If ground wire is loose, tighten connection and install nose plate.
 - c. If problem still exists, notify Organizational Maintenance.

BRAKES

3. BRAKES WILL NOT RELEASE.

- Step 1. Check position of brake valve on towing vehicle. (See operator's manual for towing vehicle.)
 - a. Move brake valve to release position.
 - b. If brake valve is correctly positioned, go to step 2.
- Step 2. Check air hoses for proper connection to towing vehicle.
 - a. If air hoses are not properly connected (Emergency to Emergency, Service to Service), reconnect gladhands.
 - b. If hoses are properly connected, go to step 3.
- Step 3. If towing vehicle is equipped with air line shut-off valves at the gladhands, check to make sure they are fully open. (See operator's manual for towing vehicle.)
 - a. If air line valves are shut off, open them fully.
 - b. If valves are open, go to step 4.
 - c. If towing vehicle is not equipped with shut-off valves, go to step 4.
- Step 4. Check air pressure gage on towing vehicle for a minimum of 90 psi (621 kPa).
 - a. If air pressure is low, build up pressure to normal level.
 - b. If air pressure is low and will not build up, troubleshoot towing vehicle air system. (See maintenance manual for towing vehicle.)
 - c. If air pressure gage indicates normal, go to step 5.

MALFUNCTION
TEST OR INSPECTION
CORRECTIVE ACTION

BRAKES - CONTINUED**3. BRAKES WILL NOT RELEASE - CONTINUED.**

- Step 5. Test operation of control valves (WP 0040).
- If control valve is defective, replace (WP 0040).
 - If control valves are operating, go to step 6.
- Step 6. Check for restriction in service air and emergency air lines.
- If air lines or hoses are restricted, replace or repair as required (WP 0037).
 - If air lines and hoses are free of restrictions, go to step 7.

WARNING

- To prevent injury, keep hands away from brake chamber push rods and slack adjusters. They will move as service brakes are operated, and will automatically apply if system pressure drops. Fingers/hands could be pinched or cut by moving parts. Failure to comply may result in injury to personnel.
- Disassembly of air brake chambers is NOT authorized. When inspecting or caging air brake chambers, do not position yourself in front of, or in line with, the chamber. Failure to follow this warning may result in injury or death to personnel.
- Discarded air brake chambers must be safely and properly disposed of. They should be disarmed prior to disposal. Failure to disarm assembly prior to disposal may, in time, result in spontaneous release of the spring chamber and its contents, causing death, personal injury, and/or property damage.
- Before performing any work on the spring brake system, chock the wheels front and rear to prevent semitrailer movement. Failure to follow this warning may result in injury or death to personnel.

- Step 7. Using soapy water, check spring brake chambers for leaks at clamp bands and hose fittings.
- If leaks are seen at brake chamber clamp band, replace spring brake chamber (WP 0038).
 - If leaks are seen at hose fitting, tighten hose fitting or replace hose (WP 0037).
 - If brake chambers are not leaking, go to step 8.
- Step 8. Remove brake drum (WP 0033) and check for broken brake shoe tension springs.
If brake shoe tension spring is broken, replace (WP 0032).

MALFUNCTION
TEST OR INSPECTION
CORRECTIVE ACTION

BRAKES - CONTINUED**4. NO BRAKES OR WEAK BRAKES.****WARNING**

A hot brake can cause serious burns. Exercise extreme caution before attempting to touch brake drum after use. Radiated heat will be felt before drum is touched. Failure to comply may result in injury to personnel.

- Step 1. Feel brake drums for abnormal cold.
- If cold, check automatic slack adjusters for proper operation (WP 0034).
 - If hot, go to step 2.
- Step 2. Check air hoses for proper connection to towing vehicle.
- If air hoses are not properly connected (Emergency to Emergency, Service to Service), reconnect gladhands.
 - If hoses are properly connected, go to step 3.
- Step 3. If towing vehicle is equipped with air line shut-off valves at the gladhands, check to make sure they are fully open. (See operator's manual for towing vehicle.)
- If air line valves are shut off, open them fully.
 - If valves are open, go to step 4.
 - If towing vehicle is not equipped with shut-off valves, go to step 4.
- Step 4. Check for open drain valves in semitrailer air reservoirs.
- If either drain valve is open, close it.
 - If both drain valves are closed, go to step 5.
- Step 5. Check air pressure gage on towing vehicle for a minimum of 90 psi (621 kPa).
- If air pressure is low, build up pressure to normal level.
 - If air pressure is low and will not build up, troubleshoot towing vehicle air system. (See maintenance manual for towing vehicle.)
 - If air pressure gage indicates normal, go to step 6.
- Step 6. Check air lines and connectors for restrictions and leaks.
- Remove any restrictions from hoses and tighten connections. Repair or replace as necessary (WP 0037).
 - If air lines and connections are not restricted or leaking, go to step 7.
- Step 7. Test operation of control valves (WP 0040).
- If control valve is defective, replace (WP 0040).
 - If control valves are operating, go to step 8.

MALFUNCTION
TEST OR INSPECTION
CORRECTIVE ACTION

BRAKES - CONTINUED**4. NO BRAKES OR WEAK BRAKES - CONTINUED.****WARNING**

To prevent injury, keep hands away from brake chamber push rods and slack adjusters. They will move as service brakes are operated, and will automatically apply if system pressure drops. Fingers/hands could be pinched or cut by moving parts. Failure to comply may result in injury to personnel.

- Step 8. Have a helper apply and hold the towing vehicle service brakes. Using soapy water, check air brake chambers for leaks at clamp bands and hose fittings.
- If leaks are seen at brake chamber clamp band, replace air brake chamber (WP 0038).
 - If leaks are seen at hose fitting, tighten hose fitting or replace hose (WP 0037).
 - If brake chambers are not leaking, go to step 9.
- Step 9. Check brake adjustment.
- If brakes are out of adjustment, check operation of automatic slack adjusters (WP 0034). Replace all defective slack adjusters.
 - If brakes are not out of adjustment, go to step 10.
- Step 10. Remove brake drum (WP 0033) and check for worn/worn out brake lining.
- If brake lining is worn out, replace brake shoes (WP 0032).
 - If brake lining is not worn, go to step 11.
- Step 11. Look for grease or oil on brake lining.
- If brake lining has grease on it, check camshaft O-ring for damage. Replace O-ring if defective (WP 0031) and replace brake shoes (WP 0032).
 - If brake lining has grease or oil on it, check wheel hub grease seal for leakage. Replace grease seal if leaking (WP 0033) and replace brake shoes (WP 0032).
 - If brake lining shows no grease or oil, go to step 12.
- Step 12. Visually check for broken or frozen camshaft roller.
- If camshaft roller is broken or frozen, replace (WP 0032).

MALFUNCTION
TEST OR INSPECTION
CORRECTIVE ACTION

BRAKES - CONTINUED**5. SLOW BRAKE APPLICATION OR RELEASE.**

- Step 1. Check air pressure gage on towing vehicle for a minimum of 90 psi (621 kPa).
- If air pressure is low, build up pressure to normal level.
 - If air pressure is low and will not build up, troubleshoot towing vehicle air system. (See maintenance manual for towing vehicle.)
 - If air pressure gage indicates normal, go to step 2.
- Step 2. Check air lines and connectors for restrictions and leaks.
- Remove any restrictions from hoses and tighten connections. Repair or replace as necessary (WP 0037).
 - If air lines and connections are not restricted or leaking, go to step 3.
- Step 3. Check control valves for plugged exhaust ports, (WP 0040).
- If exhaust port is plugged, clean valve.
 - If exhaust port is not plugged, go to step 4.
- Step 4. Test operation of control valves (WP 0040).
- If control valve is defective, replace (WP 0040).
 - If control valves are operating, go to step 5.

WARNING

To prevent injury, keep hands away from brake chamber push rods and slack adjusters. They will move as service brakes are operated, and will automatically apply if system pressure drops. Fingers/hands could be pinched or cut by moving parts. Failure to comply may result in injury to personnel.

- Step 5. Have a helper apply and hold the towing vehicle service brakes. Using soapy water, check air brake chambers for leaks at clamp bands and hose fittings.
- If leaks are seen at brake chamber clamp band, replace spring brake chamber (WP 0038).
 - If leaks are seen at hose fitting, tighten hose fitting or replace hose (WP 0037).
 - If brake chambers are not leaking, go to step 6.
- Step 6. Remove brake drum (WP 0033) and check for broken brake shoe tension spring.
- If spring is broken, replace (WP 0032).
 - If spring is not defective, go to step 7.
- Step 7. Visually check for broken or frozen camshaft roller.
If camshaft roller is broken or frozen, replace (WP 0032).

MALFUNCTION
TEST OR INSPECTION
CORRECTIVE ACTION

BRAKES - CONTINUED**6. GRABBING BRAKES.**

Step 1. Check for moisture in air reservoirs.

WARNING

Wear protective goggles when opening drain cock and avoid the air stream. Failure to comply could result in injury to personnel.

- a. Open drain cocks and allow moisture to drain (WP 0018).
- b. If no moisture is present, close drain cocks and go to step 2.

Step 2. Check brake adjustment.

- a. If brakes are out of adjustment, check operation of automatic slack adjusters (WP 0034). Replace all defective slack adjusters.
- b. If brakes are not out of adjustment, go to step 3.

Step 3. Check for loose or worn wheel bearings.

- a. If wheel bearings are loose, adjust (WP 0033).
- b. If wheel bearings cannot be adjusted, replace (WP 0033).
- c. If wheel bearings are not loose or worn, go to step 4.

Step 4. Remove brake drum (WP 0033) and look for grease or oil on brake lining.

- a. If brake lining has grease on it, check camshaft O-ring for damage. Replace O-ring if defective (WP 0031), and replace brake shoes (WP 0032).
- b. If brake lining has oil on it, check wheel hub oil seal for leakage. Replace oil seal if leaking (WP 0033), and replace brake shoes (WP 0032).
- c. If brake lining shows no grease or oil, go to step 5.

Step 5. Visually check for broken or frozen camshaft roller. Look for flat spots on camshaft roller and camshaft.

- a. If camshaft roller is broken or frozen, replace (WP 0032).
- b. If camshaft is defective, replace (WP 0031).
- c. If camshaft and roller are not defective, go to step 6.

Step 6. Check for loose or worn brake lining.

- a. If brake lining is loose or worn, replace brake shoes (WP 0032).
- b. If brake lining is not loose or worn, go to step 7.

Step 7. Check for cracked, scored, or deformed brake drum.

- a. If brake drum is cracked or deformed, replace (WP 0033).
- b. If brake drum is scored, notify Direct Support Maintenance.

MALFUNCTION
TEST OR INSPECTION
CORRECTIVE ACTION

BRAKES - CONTINUED**7. BRAKES DRAG AND ONE OR MORE BRAKE DRUMS RUNNING HOT.****WARNING**

A hot brake can cause serious burns. Exercise extreme caution before attempting to touch brake drum after use. Radiated heat will be felt before drum is touched. Failure to comply may result in injury to personnel.

- Step 1. Check brake adjustment.
- If brakes are out of adjustment or adjusted too tightly, check operation of automatic slack adjusters (WP 0034). Replace all defective slack adjusters.
 - If brakes are not out of adjustment, go to step 2.
- Step 2. Remove brake drum (WP 0033) and check for broken brake shoe tension spring.
- If spring is broken, replace (WP 0032).
 - If spring is not defective, go to step 3.
- Step 3. Visually check for broken or frozen camshaft roller. Look for flat spots on camshaft roller and camshaft.
- If camshaft roller is broken or frozen, replace (WP 0032).
 - If camshaft is defective, replace (WP 0031).
 - If camshaft and roller are not defective, go to step 4.
- Step 4. Check for cracked, scored, or deformed brake drum.
- If brake drum is cracked or deformed, replace (WP 0033).
 - If brake drum is scored, notify Direct Support Maintenance.

8. HARD PULLING.

- Step 1. Check for dragging brakes (side pull or hot drum).
- If brakes are dragging, go to MALFUNCTION 7. BRAKES DRAG AND ONE OR MORE BRAKE DRUMS RUNNING HOT.
 - If brakes are not dragging, go to step 2.
- Step 2. Check for loose or worn wheel bearings.
- If wheel bearings are loose, adjust (WP 0033).
 - If wheel bearings cannot be adjusted, replace (WP 0033).
 - If wheel bearings are not loose or worn, go to step 3.

MALFUNCTION
TEST OR INSPECTION
CORRECTIVE ACTION

BRAKES - CONTINUED**8. HARD PULLING - CONTINUED.**

- Step 3. Check for loose trunnion tube hanger bolts.
- If trunnion tube hanger bolts are loose, torque to 300 lb-ft (407 Nm).
 - If trunnion tube hanger bolts are secure, go to step 4.
- Step 4. Check for loose or broken springs.
- If springs are loose or broken, notify Direct Support Maintenance.

LANDING GEAR**9. DIFFICULTY IN TURNING HANDCRANK.**

- Step 1. Check for bent lower leg.
- If lower leg is bent, replace landing leg (WP 0050).
 - If lower leg is not bent, go to step 2.
- Step 2. Operate crank and listen for grinding gears or bearings in landing leg gear box.
- If gears or bearings grind and legs do not extend or retract properly, replace landing leg with assembled gear box (WP 0050).

SPRINGS AND SUSPENSION**10. IMPROPER SPRING ACTION.**

- Step 1. Check for loose spring end cap U-bolts.
- If U-bolts are loose, torque U-bolt locknuts to 300 lb-ft (407 Nm).
 - If U-bolts are secure, go to step 2.
- Step 2. Check springs for broken or weak spring leaves. If leaves are broken or weak, notify Direct Support Maintenance.

TIRES AND WHEELS**11. EXCESSIVELY WORN, SCUFFED, OR CUPPED TIRES.**

- Step 1. Check that cold tire pressure is 115 psi (793 kPa).
- If tire pressure is incorrect, inflate or deflate tires to correct pressure.
 - If tire pressure is correct, go to step 2.
- Step 2. Check for loose wheels.
- If wheels are loose, tighten wheel lug nuts.
 - If wheels are secure, go to step 3.

MALFUNCTION
TEST OR INSPECTION
CORRECTIVE ACTION

TIRES AND WHEELS - CONTINUED**11. EXCESSIVELY WORN, SCUFFED, OR CUPPED TIRES - CONTINUED.**

- Step 3. Visually check for bent wheel.
- Replace wheel, if bent.
 - If wheel is not bent, go to step 4.
- Step 4. Check dual tires for proper matching according to wear. (See TM 9-2610-200-24 for acceptable limits in matching tires.)
- If necessary, remove and match tires.
 - If tires are properly matched, go to step 5.
- Step 5. Check for loose or worn wheel bearings.
- If wheel bearings are loose, adjust (WP 0033).
 - If wheel bearings cannot be adjusted, replace (WP 0033).
 - If wheel bearings are not loose or worn, go to step 6.
- Step 6. Remove wheel (WP 0021) and check for deformed, cracked, or scored brake drum.
- If brake drum is cracked or deformed, replace (WP 0033).
 - If brake drum is scored, notify Direct Support Maintenance.
- Step 7. Check semitrailer tracking.
Notify Direct Support Maintenance.

END OF WORK PACKAGE

CHAPTER 5
OPERATOR PMCS MAINTENANCE

OPERATOR MAINTENANCE
OPERATOR PMCS INTRODUCTION

GENERAL

1. To ensure that the semitrailer is ready for operation at all times, it must be inspected on a regular basis so that defects may be found and corrected before they result in injury, damage, or equipment failure.
2. The PMCS Table in WP 0014 contains systematic instructions on inspections, lubrications, services, tests, and corrections to be performed by the operator to keep your equipment in good operating condition and ready for its primary mission.

EXPLANATION OF TABLE ENTRIES

1. **Item No. Column.** Numbers in this column are for reference. When completing DA Form 2404 or DA Form 5988-E (*Equipment Inspection and Maintenance Worksheet*), include the item number for the check/service indicating a fault. Item numbers also appear in the order that you must perform checks and services for the interval listed.
2. **Interval Column.** This column tells you when you must perform the procedure in the Procedure column:
 - a. *Before* procedures must be done immediately before operating the semitrailer.
 - b. *During* procedures must be done while operating the semitrailer.
 - c. *After* procedures must be done immediately after operating the semitrailer.
 - d. *Weekly* procedures must be done once each week.
 - e. *Monthly* procedures must be done once each month.
3. **Item to Check/Service Column.** This column lists the item to be checked or serviced.

NOTE

The WARNINGS and CAUTIONS appearing in your PMCS table should always be observed. WARNINGS and CAUTIONS appear before applicable procedures. You must observe these WARNINGS to prevent injury or death to yourself and others, and CAUTIONS to prevent your equipment from being damaged.

4. **Procedure Column.** This column gives the procedure you must perform to check or service the item listed in the Item to Check/Service column, to know if the equipment is ready or available for its intended mission. You must perform the procedure at the time stated in the interval column.
5. **Not Fully Mission Capable If: Column.** Information in this column tells you what faults will keep your equipment from being capable of performing its primary mission. If you perform check/service procedures that show faults listed in this column, the equipment is not mission-capable. Follow standard operating procedures for maintaining the equipment or reporting equipment failure.

GENERAL PMCS PROCEDURES

1. Always perform PMCS in the same order so it gets to be a habit. Once you have had some practice, you will spot anything wrong in a hurry. If the equipment does not perform as required, refer to the appropriate troubleshooting procedure in Chapter 3.
2. If anything looks wrong and you cannot fix it, write it on your DA Form 2404 or DA Form 5988-E. If you find something seriously wrong, IMMEDIATELY report it to your supervisor.

GENERAL PMCS PROCEDURES - CONTINUED

3. Before performing preventive maintenance, read all the checks required for the applicable interval and prepare all that is needed to make all the checks. You will always need a rag (Item 13, WP 0085) or two.

WARNING

Solvent cleaning compound MIL-PRF-680 Type III is an environmentally compliant and low toxic material. However, it may be irritating to the eyes and skin. Use protective gloves and goggles. Use in well-ventilated areas. Keep away from open flames and other sources of ignition. Failure to comply may result in injury or death to personnel.

CAUTION

Do not use high-pressure water or steam to clean semitrailer. Use only low-pressure water and bristled brushes. Be especially careful when cleaning electrical system components including lighting. Damage or impaired operation could result if this caution is not observed.

- a. **Keep Equipment Clean.** Dirt, grease, oil, and debris get in the way and may cover up a serious problem. Clean as you work and as needed. Use solvent, cleaning compound (Item 3, WP 0085) on all metal surfaces. Use detergent (Item 5, WP 0085) and water when you clean rubber, plastic, and painted surfaces. Spot paint as required to prevent corrosion.
- b. **Bolts, Nuts, and Screws.** Ensure that they are not loose, missing, bent, or broken. Report loose, missing, or damaged bolts, nuts, and screws to your supervisor.
- c. **Welds.** Look for loose or chipped paint, rust, or gaps where parts are welded together. Report bad welds to your supervisor.
- d. **Electrical Wires and Connectors.** Look for cracked or broken insulation, bare wires, and loose or broken connectors. Report loose connections and faulty wiring to your supervisor.
- e. **Hoses, Lines, and Fittings.** Look for wear and damage. Check for loose clamps and fittings. Report any worn, damaged, or loose hoses, lines, and fittings to your supervisor.

END OF WORK PACKAGE

OPERATOR MAINTENANCE**OPERATOR PMCS**

INITIAL SETUP**Maintenance Level**

Operator

Tools and Special Tools

Tool kit, general mechanic's (Item 4, WP 0082)

Materials/Parts

Cleaning compound, solvent, type III (Item 3, WP 0085)

Detergent, general purpose, liquid (Item 5, WP 0085)

Materials/Parts - Continued

Rag, wiping (Item 13, WP 0085)

Personnel Required

Two

References

WP 0018

WP 0067

WP 0097

WP 0100

Table 1. Operator Preventive Maintenance Checks and Services (PMCS).

ITEM NO.	INTERVAL	MAN-HOURS	LOCATION	PROCEDURE	NOT FULLY MISSION CAPABLE IF:
			ITEM TO CHECK/SERVICE		
				<p>CAUTION</p> <p>Reference prime mover technical manual. Ensure all operations are adhered to, i.e., coupling, fifth wheel load and position, load capabilities, speeds, on/off road operation, and adverse weather/road operations. Failure to comply could cause damage to equipment.</p> <p>NOTE</p> <p>Perform <i>Weekly</i> as well as <i>Before</i> PMCS if:</p> <ul style="list-style-type: none"> You are the assigned operator but have not operated the semitrailer since the last <i>Weekly</i> PMCS. You are operating the semitrailer for the first time. 	
1	Before		Bulkhead	<p>a. Check for loose or missing hardware.</p> <p>b. Check for serviceability and presence of side panels, tarps, bows, safety ladder, and BII as required by mission.</p>	<p>Loose or missing hardware.</p> <p>Unserviceable or missing components if required by mission.</p>
2	Before		Kingpin	<p>NOTE</p> <p>Perform the following inspections and checks before connecting the semitrailer to the towing vehicle.</p> <p>a. Visually inspect kingpin for obvious damage and wear. Make sure kingpin and bolster plate are greased.</p> <p>b. Visually inspect bolster plate for obvious damage, bowing, and cracked welds.</p> <p>c. Check to make sure bolster plate drain holes are not plugged.</p>	<p>Kingpin is damaged or shows obvious wear.</p> <p>Bolster plate is bowed or welds are cracked.</p> <p>Bolster plate drain holes are plugged.</p>
3	Before		Converter Box	Check for obvious damage or missing hardware.	Damaged or missing hardware.
4	Before		Voltage Receptacles	Visually check for damage.	Receptacles are damaged.

Table 1. Operator Preventive Maintenance Checks and Services (PMCS) - Continued.

ITEM NO.	INTERVAL	MAN-HOURS	LOCATION	PROCEDURE	NOT FULLY MISSION CAPABLE IF:
			ITEM TO CHECK/SERVICE		
5	Before		Gladhands	Inspect gladhands for damage, missing or worn/cracked packings, missing hardware, and free swing-away operation.	Gladhands are damaged, packings worn/cracked or missing, missing hardware, and restricted operation.
6	Before		Ground Boards	Check for presence and damaged/missing hardware.	Ground boards cannot be safely secured in brackets or retaining hardware/ground boards are missing.
7	Before		Chock Blocks	Check for presence.	Blocks are not present.
8	Before		Intervehicular Air Hoses	<p style="text-align: center;">CAUTION</p> <ul style="list-style-type: none"> • After coupling semitrailer with towing vehicle, the scissor shoes at the end of the landing legs must be unlocked, swung up, and locked in the up position to allow for maximum clearance. • Before uncoupling semitrailer, scissor shoes on the landing legs must be unlocked, swung down, and locked in the down position. • Chock front and rear of tires prior to coupling/uncoupling. • Failure to comply could result in damage to equipment. <p style="text-align: center;">NOTE</p> <p>The following checks must be done with the prime mover coupled to the semitrailer. Assistance is required when coupling and checking semitrailer lights.</p> <p>Connect air lines to semitrailer gladhands. With tractor engine running, check air lines and gladhands for air leaks.</p>	Air leaks are present.

Table 1. Operator Preventive Maintenance Checks and Services (PMCS) - Continued.

ITEM NO.	INTERVAL	MAN-HOURS	LOCATION	PROCEDURE	NOT FULLY MISSION CAPABLE IF:
			ITEM TO CHECK/SERVICE		
9	Before		Lights	<p>NOTE</p> <ul style="list-style-type: none"> • Check for loose plug-in connectors. Make sure there is no debris between plug and connector and then make sure that plug-in is seated. • Mission requirements, urgency, safety, and common sense should be considered in determining NMC status of the semitrailer. <p>Connect intervehicular cable from tractor to semitrailer. Check lights for damage, proper operation, presence, and missing hardware. Notify Organizational Maintenance if there are problems in operation or damage is present.</p>	Lights are damaged, do not operate, or missing hardware. NMC if required for mission.
10	Before		Reflectors	Look for presence, damage, and missing hardware.	Reflectors are missing and required for mission.
11	Before		ABS Warning Light	<p>NOTE</p> <ul style="list-style-type: none"> • Tractor must be coupled before checking ABS warning light. • ABS warning light should not stay on when semitrailer is moving above 4 mph (6.4 kph). • If mission requirements do not allow for troubleshooting of ABS system, continue on with mission until system can be properly diagnosed by Organizational Maintenance. Only modulation will be affected, not stopping capacity of brake system. <p>Visually check that ABS warning light does not stay on. Notify Organizational Maintenance.</p>	ABS light does not come on or stays on.

Table 1. Operator Preventive Maintenance Checks and Services (PMCS) - Continued.

ITEM NO.	INTERVAL	MAN-HOURS	LOCATION	PROCEDURE	NOT FULLY MISSION CAPABLE IF:
			ITEM TO CHECK/SERVICE		
12	Before		Landing Leg Assembly	<p>CAUTION</p> <ul style="list-style-type: none"> • Use high gear for rapid lowering/raising of semitrailer without a load on deck. • Use low gear for lifting/raising semitrailer with a load on deck. • Leave landing gear in low gear, in the full up position, when traveling on the road. Low gear will prevent over-the-road vibration from causing legs to wind-down (extend). Make sure crank handle is secure. • Crank operation: Facing crank, clockwise retracts (raises) legs, and counterclockwise extends (lowers) legs. • Push in - high gear, pull out - low gear. • Make sure landing legs are fully retracted and scissor shoes locked up before moving semitrailer. • Failure to comply could cause damage to equipment. <p>a. Engage landing leg crank handle and raise and lower legs. Pull crank and check low-speed operation. Check for binding, damage, unequal leg movement, and missing hardware.</p> <p>b. Check that scissor shoes have free movement, hardware is present, and shoes securely lock in place.</p>	<p>a. Landing leg missing.</p> <p>b. Leg will not retract or extend.</p> <p>c. Binds or hard to move.</p> <p>Scissor shoes bind, do not lock or unlock, and missing hardware.</p>

Table 1. Operator Preventive Maintenance Checks and Services (PMCS) - Continued.

ITEM NO.	INTERVAL	MAN-HOURS	LOCATION	PROCEDURE	NOT FULLY MISSION CAPABLE IF:
			ITEM TO CHECK/SERVICE		
13	Before		Radial Tires and Wheels	<p>CAUTION</p> <ul style="list-style-type: none"> • Rust near wheel nuts can mean low torque. • Check wheels (inner/outer) and hubcaps for grease leakage. When leakage is initially found, clean off all grease and recheck after operation. If grease leakage is still evident, notify Organizational Maintenance. • Failure to comply could cause damage to equipment. <p>NOTE</p> <ul style="list-style-type: none"> • All wheel flange nuts have right-hand threads. • Cold radial tire pressure should be 115 psi (793 kPa) for all tires. <p>a. Inspect tires, including spare, for proper inflation, unusual tread wear, sidewall damage, cuts, foreign objects, valve stem damage, valve caps, and loose/missing dust shield plugs on wheels.</p> <p>WARNING</p> <p>Make sure spare tire and wheel assembly is secured in carrier and securing hardware is present. Failure to secure the spare tire may result in the spare tire falling off of trailer, causing injury or death to personnel.</p> <p>b. Check that spare tire is secure and securing hardware is present.</p> <p>c. Check wheels for damaged rims, and rust.</p> <p>d. Check for loose or missing wheel nuts. Notify Organizational Maintenance. All the nuts must be present and torqued to specifications.</p>	<p>Tires are not properly inflated, are damaged, or show unusual wear.</p> <p>Securing hardware is unserviceable or missing.</p> <p>Wheel rims are damaged or rusty.</p>

Table 1. Operator Preventive Maintenance Checks and Services (PMCS) - Continued.

ITEM NO.	INTERVAL	MAN-HOURS	LOCATION	PROCEDURE	NOT FULLY MISSION CAPABLE IF:
			ITEM TO CHECK/SERVICE		
13 (Con't)	Before		Radial Tires and Wheels	e. Re-torque wheel nuts at first 100, 500, 1,000 miles (161, 805, 1,609 km), and every 6,000 miles (9,656 km) thereafter unless wheel is changed out. Then use re-torque schedule. Notify Organizational Maintenance (WP 0097).	Wheel nuts are loose or missing. Wheel nuts not torqued.
14	Before		Spare Tire Carrier	<p>WARNING</p> <p>Spare tire and wheel assembly weighs 179 lb (81.2 kg). This requires two people to remove the spare from the carrier or install it on the carrier. Slide the spare from the carrier or onto the carrier. Refrain from lifting the spare into position. Failure to comply could result in injury to personnel.</p> <p>NOTE</p> <p>When layed in carrier, convex side should be in the up position (stud holes up).</p> <p>Inspect spare tire carrier assembly for worn, loose, or missing securing hardware and cracked/broken welds.</p>	
15	Before		Hubcaps and HUBODOMETER®	<p>CAUTION</p> <p>Do not stand on HUBODOMETER®. Doing so could result in damage to equipment.</p> <p>a. Inspect hubcaps for damage, loose or missing hardware, and leakage.</p> <p>b. Inspect HUBODOMETER® for missing hardware, damage, and loose mounting bracket or gage.</p>	<p>Worn, loose, or missing hardware and cracked/broken welds are found.</p> <p>Hubcap is leaking grease or hardware is loose or missing.</p> <p>Hardware is loose or missing.</p>

Table 1. Operator Preventive Maintenance Checks and Services (PMCS) - Continued.

ITEM NO.	INTERVAL	MAN-HOURS	LOCATION	PROCEDURE	NOT FULLY MISSION CAPABLE IF:
			ITEM TO CHECK/SERVICE		
16	Before		Suspension	<p>WARNING</p> <p>Notify Organizational Maintenance at first month of new semitrailer operation or first 1,000 miles (1,609 km) (from HUBODOMETER®) that suspension nuts must be torqued. Reference Item No. 1 of Organizational PMCS. Failure to comply could cause loss of suspension/parts which could result in injury to personnel and damage to equipment.</p>	
17	Before		Air Reservoir Tanks	<p>Visually inspect for broken or shifted leaf springs and loose or missing hardware. Notify Organizational Maintenance.</p> <p>WARNING</p> <p>Wear protective goggles when opening drain cock and avoid the air stream. Failure to comply could result in injury to personnel.</p> <p>a. Make sure drain valves do not leak air.</p> <p>b. Inspect air tanks for damage, loose fittings, missing hardware, and any evidence of air leakage.</p> <p>c. Inspect drain valve pull cables for a frayed or broken condition.</p>	<p>Springs have shifted or are broken and hardware is loose or missing.</p> <p>Drain valves leak air.</p> <p>Any air leaks are present or hardware is missing.</p>
18	Before		Stowage Box and Door	<p>Open and close door, make sure hinge does not bind, and all mounting/securing hardware is tight and present. Make sure drain holes are not blocked. Ensure jack is secure and door seal is in good condition. Keep box clean and serviceable.</p>	<p>Hardware loose or missing.</p>

Table 1. Operator Preventive Maintenance Checks and Services (PMCS) - Continued.

ITEM NO.	INTERVAL	MAN-HOURS	LOCATION	PROCEDURE	NOT FULLY MISSION CAPABLE IF:
			ITEM TO CHECK/SERVICE		
19	Before		Twist Locks	<p>CAUTION</p> <p>Make sure there is no debris in ISO container lock slots that would prevent twist lock engagement and positive locking. Failure to comply could cause damage to equipment.</p> <p>Check to make sure there is no debris in the lock pocket that would interfere with lock operation. Make sure twist locks (all) operate freely and do not bind.</p>	Twist locks are missing and are required for mission.
20	Before		Tiedowns	<p>CAUTION</p> <p>Deformation of any part of D-ring is not allowed. Notify Organizational Maintenance. Failure to comply could cause damage to equipment.</p> <p>Check all tiedowns for missing hardware, damage, cracked welds, and deformation. Notify Organizational Maintenance.</p>	Damaged, deformed, and cracked welds are evident.
21	Before		Brakes	<p>a. With prime mover coupled, prior to start of mission, have a person observe if trailer brakes are working. Hold brake pedal down and try to slowly move tractor forward. Observe if trailer tires move. If tires move, brakes are not holding.</p> <p>b. Notify Organizational Maintenance, NMC, if trailer tires move when brakes are applied.</p>	

Table 1. Operator Preventive Maintenance Checks and Services (PMCS) - Continued.

ITEM NO.	INTERVAL	MAN-HOURS	LOCATION	PROCEDURE	NOT FULLY MISSION CAPABLE IF:
			ITEM TO CHECK/SERVICE		
22	During		ABS Warning Light	<p>NOTE</p> <ul style="list-style-type: none"> • If ABS warning light stays on during mission, continue on with mission until system can be properly diagnosed by Organizational Maintenance. Braking capacity will not be impaired. The only effect will be no modulation at wheel or wheels that have a fault. • Trailer is not NMC if during mission ABS is inoperable and there is no time to diagnose problem(s). • During blackout mode conditions, tape over ABS warning light. Do not remove or otherwise disable light. <p>Check that ABS warning light does not stay on.</p>	
23	During		Axles and Suspension	Listen for unusual noises, which are indications of possible problems. Be alert to conditions such as side pull, wandering, tracking of semitrailer, and load shift.	Unusual noises, semitrailer wanders, pulls to either side, or does not track.
24	During		General	Be alert to all conditions that may indicate unsafe operation or improperly secured cargo. Ensure all prime mover TM procedures are adhered to for safe operation, i.e., coupling load limits, speeds, and fifth wheel settings for on/off road operation.	Unsafe conditions are identified.
25	After		Landing Leg Assembly	<p>CAUTION</p> <p>Do not use high-speed cranking mode for lifting and lowering of landing gear if there is a load on the semitrailer. Failure to comply could cause damage to equipment.</p>	

Table 1. Operator Preventive Maintenance Checks and Services (PMCS) - Continued.

ITEM NO.	INTERVAL	MAN-HOURS	LOCATION	PROCEDURE	NOT FULLY MISSION CAPABLE IF:
			ITEM TO CHECK/SERVICE		
25 (Con't)	After		Landing Leg Assembly	Inspect gearbox, braces, and leg assemblies for proper operation and tight mounting hardware. Ensure there is no binding in operation, equal leg movement, and the hand crank is present and can be safely stowed.	Legs bind, are unequal in movement, missing hardware, or hand-crank cannot be safely stowed.
26	After		Brake System	<p>WARNING</p> <p>A hot brake can cause serious burns. Exercise caution before attempting to touch brake drum after use. Radiated heat will be felt before brake drum is touched. Failure to comply may result in injury to personnel.</p> <p>Cautiously feel brake drums for abnormal heat or cold. An abnormally hot drum indicates a possible dragging or grabbing brake. An abnormally cool drum indicates improper adjustment or a defective brake. Notify Organizational Maintenance.</p>	Brake drums abnormally hot or cold.
27	After		Air Reservoir Tanks	Pull reservoir drain cables to remove all condensation (WP 0018).	System is not drained of moisture.
28	After		Bolster Plate Drain Holes	Check to make sure bolster plate drain holes are not plugged with grease or debris.	Bolster plate drain holes are plugged.
29	After		Semitrailer Cleanliness	<p>a. After operation, especially in mud, salt environment, or fording conditions, flush out axles, axle ends, suspension, landing gear, underside/topside of semitrailer, and stowage box with clean, low-pressure water.</p> <p>b. Clean and lubricate all parts as specified in WP 0067 to make sure water/debris is flushed out of system.</p> <p>c. Check all electrical connections for corrosion and security.</p> <p>d. Make sure all painted surfaces are touched up where necessary to prevent rust.</p>	Not accomplished when mission permits or mission completed.

Table 1. Operator Preventive Maintenance Checks and Services (PMCS) - Continued.

ITEM NO.	INTERVAL	MAN-HOURS	LOCATION	PROCEDURE	NOT FULLY MISSION CAPABLE IF:
			ITEM TO CHECK/SERVICE		
30	Weekly		Wheels	<p>NOTE</p> <p>Mission requirements, urgency, safety, and common sense should be considered in determining NMC status of semitrailer.</p> <p>Check all wheels for handhold cracks, cracks between and around stud holes, rust streaks, and grease stains. Notify Organizational Maintenance (WP 0100).</p>	Cracks or leakage are evident.
31	Monthly		Frame and Decking	<p>Perform a visual inspection of semitrailer for evidence of corrosion and condition of upper and lower deck wood. Visually check all welds for rust and cracks. Notify Organizational Maintenance if corrosion or deck damage is evident.</p>	

END OF WORK PACKAGE

CHAPTER 6
ORGANIZATIONAL PMCS MAINTENANCE

ORGANIZATIONAL MAINTENANCE
ORGANIZATIONAL PMCS INTRODUCTION

GENERAL

1. To ensure that the semitrailer is ready for operation at all times, it must be inspected on a regular basis so that defects may be found and corrected before they result in injury, damage, or equipment failure.
2. The PMCS Table in WP 0016 contains systematic instructions on inspections, lubrications, services, tests, and corrections to be performed by Organizational Maintenance to keep your equipment in good operating condition and ready for its primary mission.

EXPLANATION OF TABLE ENTRIES

1. **Item No. Column.** Numbers in this column are for reference. When completing DA Form 2404 or DA Form 5988-E (*Equipment Inspection and Maintenance Worksheet*), include the item number for the check/service indicating a fault. Item numbers also appear in the order that you must perform checks and services for the interval listed.
2. **Interval Column.** This column tells you when you must perform the procedure in the Procedure column:
 - a. *Monthly* procedures must be done once each month.
 - b. *Semiannual* procedures must be done once every 6 months.
 - c. *Annual* procedures must be done once each year.
 - d. *Triennial* procedures must be done once every 3 years.
 - e. *Mileage* procedures must be done at the intervals specified.
3. **Item to Check/Service Column.** This column lists the item to be checked or serviced.

NOTE

The WARNINGS and CAUTIONS appearing in your PMCS table should always be observed. WARNINGS and CAUTIONS appear before applicable procedures. You must observe these WARNINGS to prevent injury or death to yourself and others, and CAUTIONS to prevent your equipment from being damaged.

4. **Procedure Column.** This column gives the procedure you must perform to check or service the item listed in the Item to Check/Service column, to know if the equipment is ready or available for its intended mission. You must perform the procedure at the time stated in the interval column.
5. **Not Fully Mission Capable If: Column.** Information in this column tells you what faults will keep your equipment from being capable of performing its primary mission. If you perform check/service procedures that show faults listed in this column, the equipment is not mission-capable. Follow standard operating procedures for maintaining the equipment or reporting equipment failure.

GENERAL PMCS PROCEDURES

1. Always perform PMCS in the same order so it gets to be a habit. Once you have had some practice, you'll spot anything wrong in a hurry. If the equipment does not perform as required, refer to the appropriate troubleshooting procedure in Chapter 4.
2. If anything looks wrong and you cannot fix it, write it on your DA Form 2404 or DA Form 5988-E. If you find something seriously wrong, IMMEDIATELY report it to your supervisor.
3. Before performing preventive maintenance, read all the checks required for the applicable interval and prepare all that is needed to make all the checks. You will always need a rag (Item 13, WP 0085) or two.

WARNING

Solvent cleaning compound MIL-PRF-680 Type III is an environmentally compliant and low toxic material. However, it may be irritating to the eyes and skin. Use protective gloves and goggles. Use in well-ventilated areas. Keep away from open flames and other sources of ignition. Failure to do so may result in injury or death to personnel.

CAUTION

Do not use high-pressure water or steam to clean semitrailer. Use only low-pressure water and bristled brushes. Be especially careful when cleaning electrical system components including lighting. Damage or impaired operation could result if this caution is not observed.

- a. **Keep Equipment Clean.** Dirt, grease, oil, and debris get in the way and may cover up a serious problem. Clean as you work and as needed. Use solvent, cleaning compound (Item 3, WP 0085) on all metal surfaces. Use detergent (Item 5, WP 0085) and water when you clean rubber, plastic, and painted surfaces. Spot paint as required to prevent corrosion.
- b. **Bolts, Nuts, and Screws.** Ensure that they are not loose, missing, bent, or broken. Report loose, missing, or damaged bolts, nuts, and screws to your supervisor.
- c. **Welds.** Look for loose or chipped paint, rust, or gaps where parts are welded together. Report bad welds to your supervisor.
- d. **Electrical Wires and Connectors.** Look for cracked or broken insulation, bare wires, and loose or broken connectors. Report loose connections and faulty wiring to your supervisor.
- e. **Hoses, Lines, and Fittings.** Look for wear and damage. Check for loose clamps and fittings. Report any worn, damaged, or loose hoses, lines, and fittings to your supervisor.

END OF WORK PACKAGE

ORGANIZATIONAL MAINTENANCE**ORGANIZATIONAL PMCS**

INITIAL SETUP**Maintenance Level**

Organizational

Tools and Special Tools

Tool kit, general mechanic's (Item 4, WP 0082)

Materials/Parts

Antiseize compound (Item 1, WP 0085)

Brush, scrub (Item 2, WP 0085)

Cleaning compound, solvent, type III
(Item 3, WP 0085)

Detergent, general purpose, liquid (Item 5, WP 0085)

Grease, dielectric (silicone) (Item 7, WP 0085)

Linseed oil (Item 9, WP 0085)

Materials/Parts - Continued

Rag, wiping (Item 13, WP 0085)

UV wood protector (Item 18, WP 0085)

Personnel Required

Two

References

TB 9-2510-242-40

WP 0067

WP 0090

WP 0091

WP 0096

WP 0097

WP 0111

Table 1. Organizational Preventive Maintenance Checks and Services (PMCS).

ITEM NO.	INTERVAL	MAN-HOURS	LOCATION	PROCEDURE	NOT FULLY MISSION CAPABLE IF:
			ITEM TO CHECK/SERVICE		
1	First Month or First 1,000 Miles of Operation		Suspension Initial Torque	<p align="center">NOTE</p> <ul style="list-style-type: none"> Perform Operator PMCS prior to, or in conjunction with, Organizational PMCS if there is a delay between daily operation of the equipment and the Organizational PMCS or regular operator is not assisting/participating. Clean axle and suspension system with low-pressure water and fiber brush to allow for careful inspection. <p>a. Torque suspension nuts to the following in-service DRY torque values:</p> <p>1-1/8 in.-12 UNF . . 880 lb-ft (1,193 Nm) 3/4 in.-16 UNF300 lb-ft (407 Nm) 5/8 in.-18 UNF180 lb-ft (244 Nm)</p> <p>b. New replacement installations/hardware should have WET (oiled) fasteners. The following wet torque values apply:</p> <p>1-1/8 in.-12 UNF . . 670 lb-ft (908 Nm) 3/4 in.-16 UNF220 lb-ft (298 Nm) 5/8 in.-18 UNF130 lb-ft (176 Nm)</p>	Torque service requirements/schedule are not met. Nuts or bolts are damaged.

Table 1. Organizational Preventive Maintenance Checks and Services (PMCS) - Continued.

ITEM NO.	INTERVAL	MAN-HOURS	LOCATION	PROCEDURE	NOT FULLY MISSION CAPABLE IF:
			ITEM TO CHECK/SERVICE		
2	Semiannual or Every 6,000 Miles		Bolster Plate	<p>CAUTION</p> <ul style="list-style-type: none"> Any bumps, valleys, or warping of the bolster plate will cause uneven loading of the fifth wheel, which could result in damage to the top plate and poor lock life (WP 0091). The bolster plate should not bow upward (concave) more than 1/16 in. (1.58 mm) within a 19 in. (48.26 cm) radius from kingpin. Failure to comply may result in damage to equipment. The bolster plate should not bow downward (convex) more than 1/4 in. (6.35 mm) within a 19 in. (48.26 cm) radius from kingpin or more than 1/8 in. (3.18 mm) at a 10 in. (254 mm) radius from kingpin. Failure to comply may result in damage to equipment. <p>a. Clean bolster plate and kingpin (WP 0090). Regrease after checks are completed.</p> <p>b. Check flatness of bolster plate using a 48 in. (1.22 m) straightedge. Check flat edge in all directions.</p>	
3	Semiannual or Every 6,000 Miles		Kingpin	<p>a. Inspect kingpin for straightness using a square (WP 0090).</p> <p>b. Lube and clean kingpin and plate.</p> <p>NOTE</p> <ul style="list-style-type: none"> Use kingpin gage to check wear, straightness, and flatness of kingpin and bolster plate. Dimensions are for both the mushroom base and cruciform kingpins. 	Kingpin is not square.

Table 1. Organizational Preventive Maintenance Checks and Services (PMCS) - Continued.

ITEM NO.	INTERVAL	MAN-HOURS	LOCATION	PROCEDURE	NOT FULLY MISSION CAPABLE IF:
			ITEM TO CHECK/SERVICE		
3 (Con't)	Semiannual or Every 6,000 Miles		Kingpin	<p>c. Dimensions and wear:</p> <p>1. Length: 3.324 + 0.010 to 0.000 in. (84.43 + 0.25 to 0.00 mm) (new).</p> <p>2. Wear: upper diameter at the bolster plate should measure: New: 2.875 in. (73.03 mm) Worn: Max. 2.75 in. (69.9 mm)</p> <p>3. The flat surfaces above and below the locking area are allowed no wear.</p> <p>4. Fifth wheel locking area on kingpin should measure: New: 2.000 in. (50.8 mm) Worn: Max. 1.87 in. (47.5 mm)</p> <p>5. Surface damage criteria: Any burrs, nicks, or gouges that exceed 0.12 in. (3.1 mm) in depth, or burrs that exceed this measurement in height on the upper diameter at bolster plate and/or at the locking area of kingpin, should have kingpin replaced. Notify Direct Support Maintenance.</p>	<p>Wear meets or exceeds maximum.</p> <p>Wear is evident.</p> <p>Wear meets or exceeds maximum.</p> <p>Surface damage meets or exceeds criteria.</p>

Table 1. Organizational Preventive Maintenance Checks and Services (PMCS) - Continued.

ITEM NO.	INTERVAL	MAN-HOURS	LOCATION ITEM TO CHECK/ SERVICE	PROCEDURE	NOT FULLY MISSION CAPABLE IF:
3 (Con't)	Semiannual or Every 6,000 Miles		Kingpin	 <p>6. No burrs, nicks, or gouges are allowed on the lower collar area of the kingpin below the locking area. Notify Direct Support Maintenance to replace kingpin.</p> <p style="text-align: center;">CAUTION</p> <p>Direct Support Maintenance: When replacing kingpin, inspect all supporting structures for rust, broken welds, and proper drainage. Structure area interior must be inspected and protected against rust. Proper drainage must be maintained. Failure to comply could result in damage to equipment.</p> <p>7. The area against the bolster plate and locking area on the kingpin should have no more than 10 burrs, nicks, or gouges that exceed 0.06 in. (1.5 mm) in depth on the entire surface area. If these criteria are met or exceeded, replace the kingpin. Notify Direct Support Maintenance.</p>	<p>Damage meets or exceeds criteria.</p> <p>Damage meets or exceeds criteria.</p>

Table 1. Organizational Preventive Maintenance Checks and Services (PMCS) - Continued.

ITEM NO.	INTERVAL	MAN-HOURS	LOCATION	PROCEDURE	NOT FULLY MISSION CAPABLE IF:
			ITEM TO CHECK/SERVICE		
3 (Con't)	Semiannual or Every 6,000 Miles		Kingpin	8. Any burrs, nicks, or gouges that meet or exceed 0.25 in. (6.4 mm) in length will require replacement of the kingpin. Notify Direct Support Maintenance.	Damage meets or exceeds criteria.
4	Semiannual or Every 6,000 Miles		Converter Box	Check converter box and internal wiring for damage and connectors for security and corrosion. Use corrosion preventive compounds (dielectric) on all electrical contacts.	Wiring damaged, not secured, or corroded.
5	Semiannual or Every 6,000 Miles		Landing Legs	Check alignment of landing legs with a square. Legs must be parallel and square with trailer.	Legs are not parallel or square with trailer.
6	Semiannual or Every 6,000 Miles		Main Electrical Harness and All Electrical Connections	Check condition of electrical harness for wear, frayed insulation, corrosion, and that connectors are secured. Use corrosion preventive compounds (dielectric) on all electrical contacts.	Harness is worn through, corroded, or unsecured. Electrical connections are loose or corroded.
7	Semiannual or Every 6,000 Miles		Suspension	<p>a. Check serviceability of suspension hardware. Check for wear and damage. Notify Direct Support Maintenance.</p> <p>b. Torque suspension nuts to the following in-service DRY torque values: 1-1/8 in.-12 UNF 880 lb-ft (1,193 Nm) 3/4 in.-16 UNF300 lb-ft (407 Nm) 5/8 in.-18 UNF180 lb-ft (244 Nm)</p> <p>c. New replacement installations/hardware should have WET (oiled) fasteners. The following wet torque values apply: 1-1/8 in.-12 UNF . . 670 lb-ft (908 Nm) 3/4 in.-16 UNF220 lb-ft (298 Nm) 5/8 in.-18 UNF130 lb-ft (176 Nm)</p>	<p>Threads are worn or hardware damaged.</p> <p>Threads are worn or hardware damaged.</p> <p>Suspension nuts not torqued.</p>
8	Semiannual or Every 6,000 Miles		Leaf Springs and Attaching Parts	<p>a. Check for missing or damaged hangers, end caps, spring seats, adjustment plates, and hardware.</p> <p>b. Check for the following: 1. One or more of the leaves in any spring assembly are broken.</p>	<p>Leaf spring attachments or hardware is missing.</p> <p>Leaf or leaves are not replaced.</p>

Table 1. Organizational Preventive Maintenance Checks and Services (PMCS) - Continued.

ITEM NO.	INTERVAL	MAN-HOURS	LOCATION	PROCEDURE	NOT FULLY MISSION CAPABLE IF:
			ITEM TO CHECK/SERVICE		
8 (Con't)	Semiannual or Every 6,000 Miles		Leaf Springs and Attaching Parts	2. Any leaf or portion of any leaf in any spring assembly is missing or separated. NOTE The three bottom leaves of each spring pack are the main leaves in each pack. 3. Any broken main leaf in a spring assembly.	Leaf is missing or separated.
9	Semiannual or Every 6,000 Miles		HUBODOMETER®	Check HUBODOMETER® bracket and gage for looseness and missing hardware. Torque gage nut to 15 lb-ft (20.3 Nm) max.	Main leaf is not replaced.
10	Semiannual or Every 6,000 Miles		Hub Caps	CAUTION <ul style="list-style-type: none"> Do not use paints or solvents on HUBODOMETER® polycarbonate face. Do not stand on HUBODOMETER®. Failure to comply could result in damage to equipment. NOTE <ul style="list-style-type: none"> If HUBODOMETER® has a bent or stripped stud, case damage, improper bracket, or hardware or case tampering, it will not perform properly. Inside of hub cap should have a light coat of grease. Do not plug vent hole. Check hub caps (4 ea.) for leaks, damage, and missing hardware and torque nuts to 15 lb-ft (20.3 Nm) max.	
11	Semiannual or Every 6,000 Miles		Reflectors	If screws are removed/replaced apply a light coat of antiseize compound to all threads.	

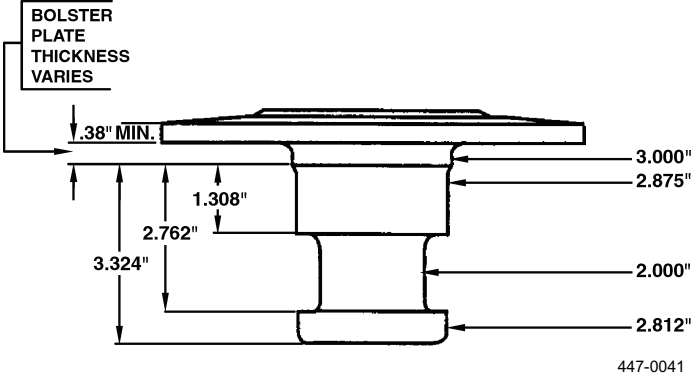
Table 1. Organizational Preventive Maintenance Checks and Services (PMCS) - Continued.

ITEM NO.	INTERVAL	MAN-HOURS	LOCATION	PROCEDURE	NOT FULLY MISSION CAPABLE IF:
			ITEM TO CHECK/SERVICE		
12	Semiannual or Every 6,000 Miles		Air Brake Chamber	<p>WARNING</p> <ul style="list-style-type: none"> Disassembly of air brake chambers is NOT authorized. When inspecting or caging air brake chambers, do not position yourself in front of, or in line with, the chamber. Failure to follow this warning may result in injury or death to personnel. Discarded air brake chambers must be safely and properly disposed of. They should be disarmed prior to disposal. Failure to disarm assembly prior to disposal may, in time, result in spontaneous release of the spring chamber and its contents, causing death, personal injury, and/or property damage. Before performing any work on the spring brake system, chock the wheels front and rear to prevent semitrailer movement. Failure to follow this warning may result in injury or death to personnel. Discarded air brake chambers must be safely and properly disposed of. They should be disarmed prior to disposal to prevent present and future injury to personnel (WP 0096). <p>Clean and visually inspect clamp bands, castings (case), and fasteners for looseness, damage, and missing hardware or leaking air.</p>	Hardware is loose or missing or castings are damaged or leaking air.
13	Semiannual or Every 6,000 Miles		Studs and Flange Nuts	<p>a. Check studs and flange nuts for damage.</p> <p>NOTE</p> <p>All flange nuts and studs have right-hand threads.</p>	Studs or flange nuts are damaged or loose. Any nuts or studs are missing.

Table 1. Organizational Preventive Maintenance Checks and Services (PMCS) - Continued.

ITEM NO.	INTERVAL	MAN-HOURS	LOCATION	PROCEDURE	NOT FULLY MISSION CAPABLE IF:
			ITEM TO CHECK/SERVICE		
13 (Con't)	Semiannual or Every 6,000 Miles		Studs and Flange Nuts	b. Flange nut torque: Torque flange nuts to 50 lb-ft (67.8 Nm) and then tighten to 450 to 500 lb-ft (610 to 678 Nm) using DRY torque. c. Torquing sequence is as follows: Using DRY torque for flange nuts and studs, facing wheel, clockwise sequence starting at top (WP 0097).	
14	Semiannual or Every 6,000 Miles		Automatic Slack Adjusters (ASAs)	<p style="text-align: center;">CAUTION</p> <ul style="list-style-type: none"> • Do not use air or electric tools to adjust ASAs. • Initial adjusting procedures start with measurements, not teardown. • Failure to comply could cause damage to equipment. Check for any binding, broken, worn or loose parts, missing hardware, evidence of an out-of-adjustment condition, worn clutch, and release action.	Binding, wear, loose parts, missing hardware, out-of-adjustment conditions are evident.
15	Annual or Every 12,000 Miles		Axles	Check axles for proper alignment (refer to WP 0111 and TB 9-2510-242-40, Nov 95, pages 21 to 25). If suspension is damaged, notify Direct Support Maintenance.	Axles are not in alignment.
16	Annual or Every 12,000 Miles		Wood Decking Corrosion	Apply a thin coat of UV wood or linseed oil protector to upper and lower deck surfaces.	Board(s) are broken or missing.

Table 1. Organizational Preventive Maintenance Checks and Services (PMCS) - Continued.

ITEM NO.	INTERVAL	MAN-HOURS	LOCATION	PROCEDURE	NOT FULLY MISSION CAPABLE IF:
			ITEM TO CHECK/SERVICE		
17	Triennial or Every 36,000 Miles		Wheel Bearings	<p>WARNING</p> <ul style="list-style-type: none"> Do not use air pressure or a steel bristle brush to clean cones and rollers. Use kerosene or diesel fuel to clean bearings. Do not use gasoline. Do not rotate bearings using compressed air, as this will damage the polished surfaces. Bearing failure can cause injury to personnel. At triennial brake inspection/service all brake wheel end components must be cleaned and inspected for wear/damage. Inspect all linings, springs, pins, rollers, clips, and bushings on each axle end. Make sure seals show no signs of leakage on axle, spider, or wheels. Use all components of replacement kits and balance repairs on both axle ends. Failure to comply can cause injury to personnel and damage to equipment. <p>Clean, inspect, and repack inner and outer cones and rollers. Replace if damaged or worn.</p>	Components worn or damaged.
18	Triennial or Every 36,000 Miles		Seals	<p>Check condition of seals for indicators of problems. When seal is removed, it should be replaced. Use correct seal installation tool to drive/set seal and never reuse a seal.</p>	Seal is damaged, worn, or leaking.
19	Triennial or Every 36,000 Miles		Spindle	<p>Check spindle for damaged threads and surface area for rust/pitting. Notify Direct Support Maintenance.</p>	Spindle is damaged.
20	Triennial or Every 36,000 Miles		Brake Drums	<p>Check drums for cracking, heat discoloration, grooving, elongated bolt holes, out-of-round, or wear beyond re-bore limit on drum. Notify Direct Support Maintenance concerning wear, re-boring, and out-of-round conditions.</p>	Drum is cracked, severely overheated, has elongated holes, or is out-of-round.

Table 1. Organizational Preventive Maintenance Checks and Services (PMCS) - Continued.

ITEM NO.	INTERVAL	MAN-HOURS	LOCATION	PROCEDURE	NOT FULLY MISSION CAPABLE IF:
			ITEM TO CHECK/SERVICE		
21	Triennial or Every 36,000 Miles		ABS Sensors	<p>CAUTION</p> <p>Push sensor to tone ring using a wooden rod or by hand. Sensor should be pushed against tone ring and will self-adjust in use. A gap of 0.040 in. (1.02 mm) is allowable. Excessive gap may cause diagnostic fault.</p> <p>Check that sensor pick-ups are lightly touching tone ring, or have a gap of no more than 0.040 in. (1.02 mm) between the tone ring and pick-up end.</p>	
22	Triennial or Every 36,000 Miles		Brake Systems	<p>a. Check brake lining thickness, springs, anchor pins, bushings, and rollers for damage and wear.</p> <p>WARNING</p> <p>Do not allow brake lining to wear to the point that the rivets touch the drum. This condition can cause brake failure, injury to personnel, and damage to equipment.</p> <p>CAUTION</p> <p>To ensure a balanced braking system, both brake assemblies on an axle end should have like repairs accomplished at the same time. Failure to comply could cause damage to equipment.</p> <p>b. See WP 0067 for lubrication points.</p>	Linings are worn to limit. Springs, anchor pins, bushings, and rollers are damaged or worn.
23	Triennial or Every 36,000 Miles		S-Cams	<p>Check for wear and damage to spline, bushings, cam lobes, and retaining brackets. Replace bushings.</p>	Damage/wear affects operation.

Table 1. Organizational Preventive Maintenance Checks and Services (PMCS) - Continued.

ITEM NO.	INTERVAL	MAN-HOURS	LOCATION	PROCEDURE	NOT FULLY MISSION CAPABLE IF:
			ITEM TO CHECK/SERVICE		
24	Triennial or Every 36,000 Miles		Hubs	<p>WARNING</p> <ul style="list-style-type: none"> The triennial (3 years) 36,000 miles check/service is based on normal operation. Conditions identified such as hot/cold brake drums, leakage/seepage of spindle/hub grease, brake lock-up, wheel end noise/damage, and impact damage will require inspection and repair to be performed when the incident occurs, not at service interval. Failure to comply can cause injury to personnel and damage to equipment. A hot brake can cause serious burns. Exercise extreme caution before attempting to touch brake drum after use. Radiated heat will be felt before drum is touched. Failure to comply may result in injury to personnel. <p>Clean and check hubs for wear and damage, including tone rings. Replace hub with tone ring if damaged or worn.</p>	Hub or tone ring is worn or damaged.

END OF WORK PACKAGE

CHAPTER 7
OPERATOR MAINTENANCE

OPERATOR MAINTENANCE
ELECTRICAL CONNECTORS CLEANING

INITIAL SETUP**Maintenance Level**

Operator

Materials/Parts

Brush, scrub (Item 2, WP 0085)

Detergent, general purpose, liquid (Item 5, WP 0085)

Rag, wiping (Item 13, WP 0085)

WARNING

Disconnect electrical power source before performing any cleaning on the electrical system.

Failure to comply may result in injury to personnel.

1. Use a rag to remove any buildup of grease and dirt on electrical connectors (Figure 1, Item 1).
2. Use a brush, detergent, and water to clean metal surfaces.
3. Allow to dry.

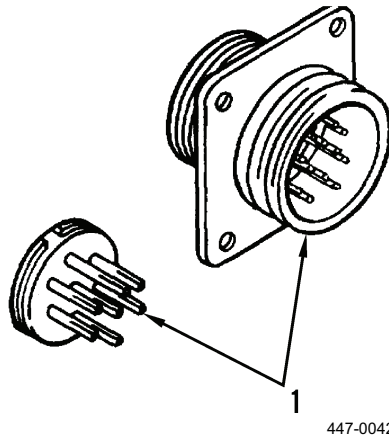

Figure 1. Electrical Connectors.

END OF TASK**END OF WORK PACKAGE**

OPERATOR MAINTENANCE**AIR RESERVOIRS SERVICE**

INITIAL SETUP**Maintenance Level**

Operator

References

WP 0041

WP 0042

Materials/Parts

Rag, wiping (Item 13, WP 0085)

-
1. Turn off air supply to semitrailer.
 2. Unhook gladhands from air hose couplings (WP 0041 or WP 0042).

WARNING

Wear protective goggles when opening drain valve and avoid the air stream. Failure to comply may result in injury to personnel.

NOTE

Refer to WP 0002, Figure 2 for location of cables.

3. Pull cable (Figure 1, Item 1) to open drain valve (Figure 1, Item 2) and allow pressure to drain.
4. Release cable (Figure 1, Item 1) to close drain valve (Figure 1, Item 2).

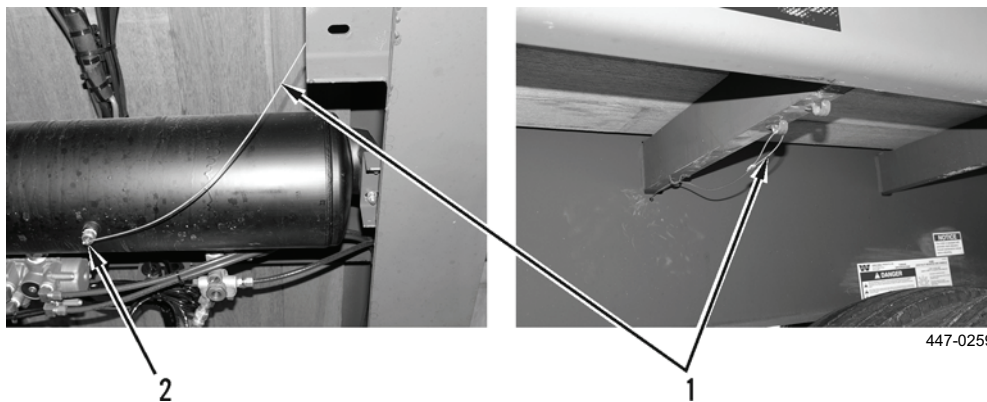

Figure 1. Drain Valve.

5. Connect gladhands to air hose couplings (WP 0041 or WP 0042).

END OF TASK**END OF WORK PACKAGE**

OPERATOR MAINTENANCE
GLADHANDS CLEANING

INITIAL SETUP
Maintenance Level

Operator

Materials/Parts

Detergent, general purpose, liquid (Item 5, WP 0085)

Rag, wiping (Item 13, WP 0085)

NOTE

For the M871R, the dummy coupling has to be removed.

1. Remove dust shield from gladhands.
2. Use a clean rag to remove any buildup of grease and dirt from gladhands (Figure 1, Item 1).
3. Use a clean rag, detergent, and water to thoroughly clean packings (Figure 1, Item 2).

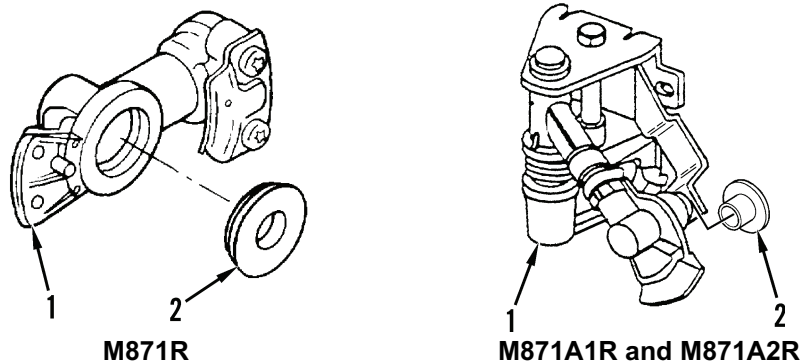

447-0197

Figure 1. Gladhands.

4. Allow to dry.
5. Reinstall dust shield clean/seal.

END OF TASK
END OF WORK PACKAGE

OPERATOR MAINTENANCE
LANDING GEAR LEGS CLEANING

INITIAL SETUP**Maintenance Level**

Operator

Materials/Parts

Brush, scrub (Item 2, WP 0085)

Detergent, general purpose, liquid (Item 5, WP 0085)

Rag, wiping (Item 13, WP 0085)

-
1. Use a clean rag to remove any buildup of grease and dirt from landing gear leg (Figure 1, Item 1).
 2. Use a brush, water, and detergent to thoroughly clean landing gear leg (Figure 1, Item 1).

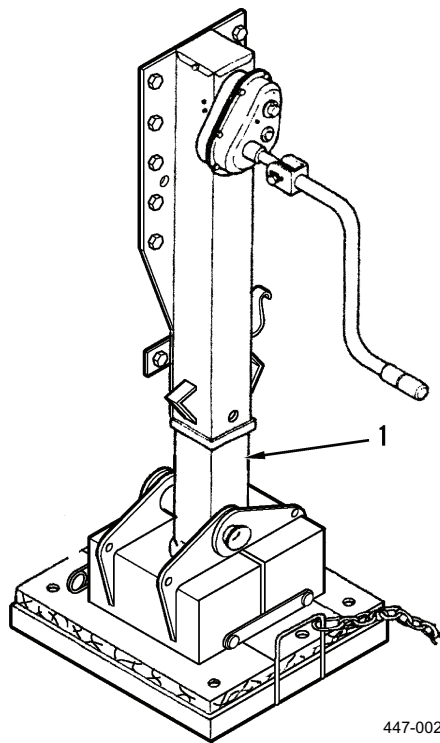

Figure 1. Landing Gear Leg.

3. Allow to dry.

END OF TASK**END OF WORK PACKAGE**

OPERATOR MAINTENANCE
TIRE AND WHEEL ASSEMBLY REPLACEMENT
Removal, Installation, Follow-On Tasks

INITIAL SETUP
Maintenance Level

Operator

References

WP 0022

WP 0097

Tools and Special Tools

Tool kit, general mechanic's (Item 4, WP 0082)

Floor jack

Jack stands

Equipment Conditions

Landing legs down

Ground boards emplaced

Tires chocked

Semitrailer disconnected from towing vehicle

Personnel Required

Two

WARNING

- Floor jack, if used, must be positioned directly under axle to prevent slippage. Floor jack must be used only on a hard, level surface to prevent shifting of semitrailer. Direct all personnel to stay clear of semitrailer when supported in the air. Failure to comply may result in injury or death to personnel or damage to equipment.
- Tire and wheel assembly weighs 179 lb (81 kg). Use two personnel to handle tire and wheel assembly. Failure to comply may result in injury to personnel.
- For service and repair tasks on the semitrailer, the ground boards and tire chocks should be used to ensure safe coupling and prevent semitrailer movement. Failure to comply may result in injury or death to personnel.

NOTE

- Replacement in the form of tire and wheel assembly changing is also an operator task. Refer to WP 0022 to remove the spare tire and wheel assembly from the carrier.
- If floor jack and jack stands are not available, use basic issue 12-ton (10.9-metric-ton) jack.
- There are eight tire and wheel assemblies and they are all replaced the same way. This procedure covers one tire and wheel assembly.

REMOVAL

1. Chock tires on axle not being lifted.
2. Position jack on ground board under axle closest to where tire(s) will be removed, as shown.
3. Loosen, but do not remove, 10 nuts (Figure 1, Item 1) while tires are in contact with ground. If necessary, use a cheater pipe for additional leverage.
4. Jack up axle until tire and wheel assemblies (Figure 1, Items 2 and 3) clear the ground.
5. Remove 10 nuts (Figure 1, Item 1) and 2 tire and wheel assemblies (Figure 1, Items 2 and 3).
6. Check lugs and wheel studs for damage and replace as needed.

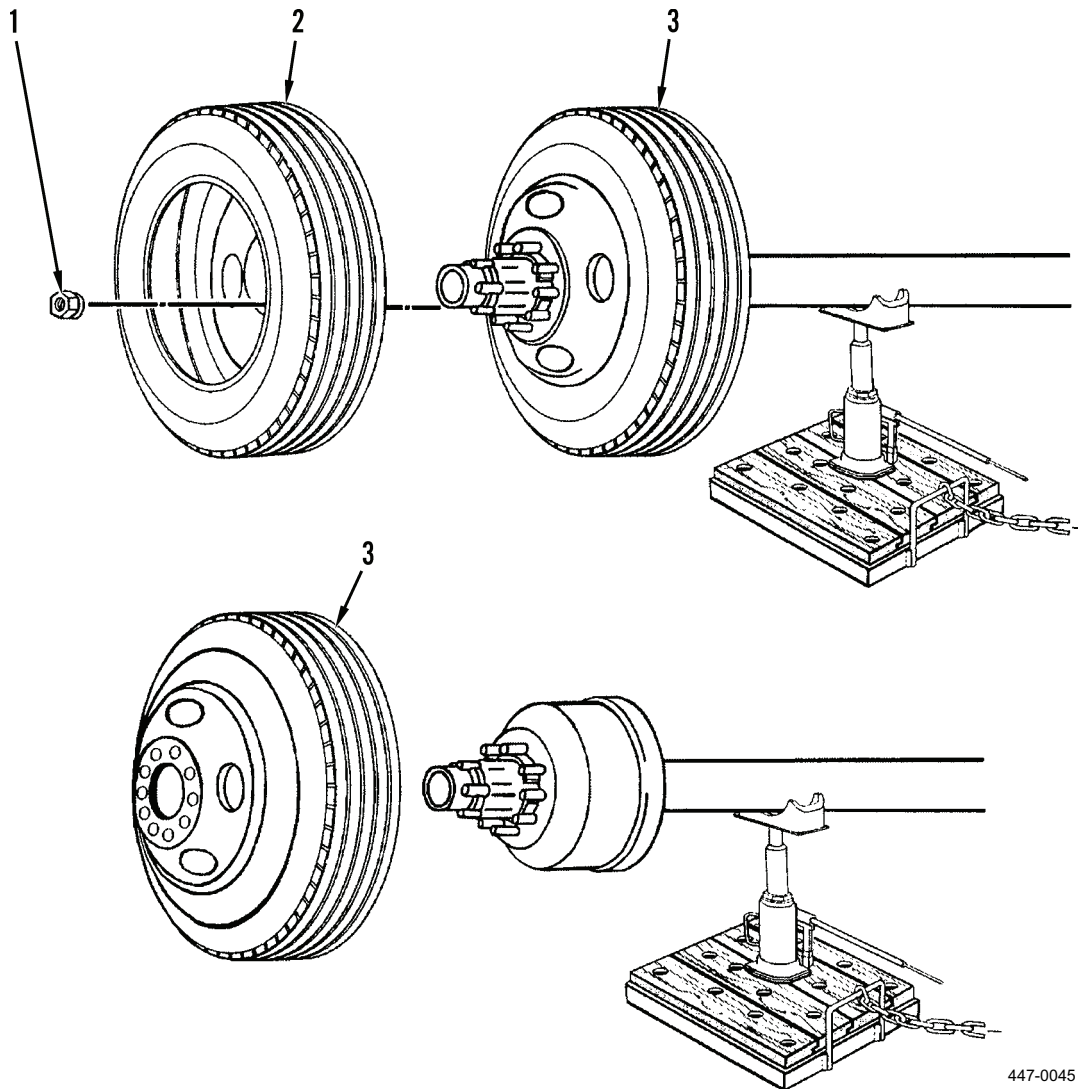
**Figure 1. Tire and Wheel Assembly.****END OF TASK**

INSTALLATION

1. Using a floor jack or 12-ton jack, raise axle high enough the tire and wheel assemblies (Figure 1, Items 3 and 2) can be mounted on axle.
2. Install tire and wheel assemblies (Figure 1, Items 3 and 2) and 10 nuts (Figure 1, Item 1). Torque nuts to 50 lb-ft (68 Nm).

WARNING

If nuts cannot be torqued, at first opportunity have Organizational Maintenance torque nuts to proper specifications. If mission allows, stop and check nuts for tightness. Failure to comply may result in injury to personnel or damage to equipment.

3. To ensure secure seating of tire, see WP 0097 for correct torquing sequence.
4. Lower tires (Figure 1, Items 3 and 2) to the ground and torque 10 nuts (Figure 1, Item 1) to 450 to 500 lb-ft (610 to 678 Nm).

END OF TASK**FOLLOW-ON TASKS**

1. Remove all jacks/stands.
2. Connect semitrailer to towing vehicle (if required).
3. Raise landing legs (if required).
4. Remove/store chocks and ground boards.
5. Check air pressure for 115 psi (793 kPa).
6. Ensure proper torque has been applied to nuts.
7. Store damaged tire and wheel assembly in spare tire carrier and secure (WP 0022).

END OF TASK**END OF WORK PACKAGE**

OPERATOR MAINTENANCE**SPARE TIRE AND WHEEL ASSEMBLY REPLACEMENT****Removal, Installation**

INITIAL SETUP**Maintenance Level**

Operator

Personnel RequiredTwo

WARNING

Spare tire and wheel assembly weighs 179 lb (81 kg). Use two personnel to remove spare tire and wheel assembly from carrier or install onto carrier. Slide spare tire and wheel assembly from carrier or onto carrier. Refrain from lifting spare tire and wheel assembly. Failure to comply may result in injury to personnel.

REMOVAL

1. Unhook snap (Figure 1, Item 1) from chain (Figure 1, Item 2).
2. Pull/slide spare tire and wheel assembly (Figure 1, Item 3) from spare tire carrier (Figure 1, Item 4) and lower to ground with tire resting against tire carrier.

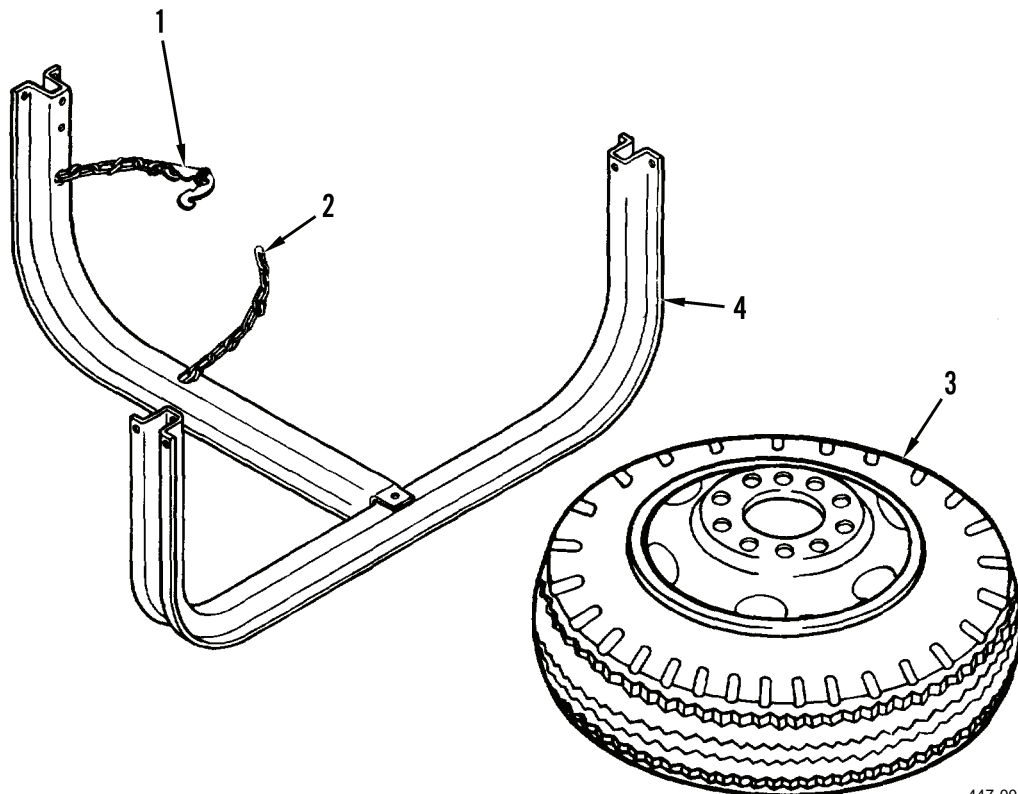

447-0046

Figure 1. Spare Tire and Wheel Assembly.**END OF TASK**

INSTALLATION

1. Install spare tire and wheel assembly (Figure 2, Item 3) in spare tire carrier (Figure 2, Item 4).
2. Route chain (Figure 2, Item 2) through two 1/8 in. diameter holes in spare tire carrier (Figure 2, Item 4).
3. Bring end of chain (Figure 2, Item 2) through center of spare tire and wheel assembly (Figure 2, Item 3).
4. Take up slack in chain (Figure 2, Item 2).
5. Hook snap (Figure 2, Item 1) to chain (Figure 2, Item 2) to secure spare tire and wheel assembly (Figure 2, Item 3).

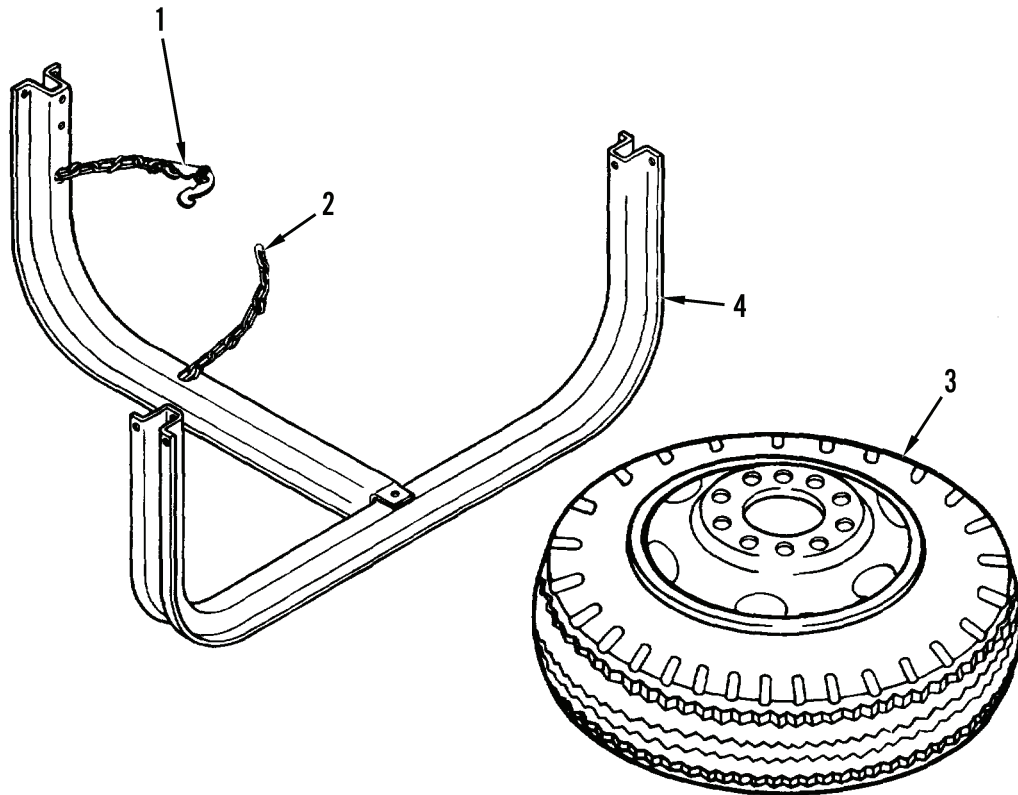

447-0046

Figure 2. Spare Tire and Wheel Assembly.**END OF TASK****END OF WORK PACKAGE**

CHAPTER 8
ORGANIZATIONAL MAINTENANCE

ORGANIZATIONAL MAINTENANCE

GENERAL MAINTENANCE INSTRUCTIONS

General, Work Safety, Cleaning Instructions, Inspection Instructions, Repair Instructions, Tagging Wires and Hoses, Corrosion Protection, Electrical Schematic

INITIAL SETUP

Maintenance Level

Organizational

Tools and Special Tools

Tool kit, general mechanic's (Item 4, WP 0082)

Materials/Parts

Brush, scrub (Item 2, WP 0085)

Cleaning compound, solvent, type III (Item 3, WP 0085)

Cloth, abrasive (Item 4, WP 0085)

Detergent, general purpose, liquid (Item 5, WP 0085)

Materials/Parts - Continued

Linseed oil (Item 9, WP 0085)

Rag, wiping (Item 13, WP 0085)

Rust inhibitor (Item 14, WP 0085)

Tag, marker (Item 16, WP 0085)

UV wood protector (Item 18, WP 0085)

References

TB 9-2510-242-40

TM 9-214

TM 9-247

WP 0067

WARNING

For service and repair tasks on the semitrailer, the ground boards and tire chocks should be used to ensure safe coupling and prevent semitrailer movement. Failure to comply may result in injury or death to personnel.

GENERAL

1. This work package contains general shop practices and specific methods you must be familiar with to properly maintain your semitrailer. You should read and understand these practices and methods before performing any maintenance tasks.
2. Before beginning a task, find out how much repair, modification, or replacement is needed to fix the equipment. Sometimes the reason for equipment failure can be seen right away, and complete teardown is not necessary. Disassemble equipment only as far as necessary to repair or replace damaged or broken parts.
3. Resources are not listed in the initial setup unless they apply to the procedure.
4. All tags and forms attached to equipment must be checked to learn the reason for equipment's removal from service. Modification Work Orders (MWOs) and Technical Bulletins (TBs) must also be checked for equipment changes and updates.
5. In some cases, a part may be damaged by removal. If the part appears to be good, and other parts behind it are not defective, leave it on and continue with the procedure. Here are a few simple rules:
 - a. Do not remove dowel pins or studs unless loose, bent, broken, or otherwise damaged.
 - b. Do not remove bearings or bushings unless damaged. If you need to remove them to access parts behind, pull bearings and bushings out carefully.
 - c. Replace all gaskets, seals, preformed packings, lockwashers, cotter pins, and other locking hardware.
 - d. Ensure all parts are lubricated as specified in WP 0067.

END OF TASK

WORK SAFETY

1. Observe all WARNINGS, CAUTIONS, and NOTES. Always use power tools carefully.
2. Protect yourself against injury. Wear protective gear such as safety goggles or lenses, safety shoes, rubber apron, and gloves.
3. When lifting heavy parts, have someone help you. Ensure that lifting/stabilizing equipment is working properly, is suitable for the assigned task, and is secure against slipping.
4. All maintenance should be performed with:
 - a. Prime mover in Neutral with parking brake engaged, if attached.
 - b. Prime mover engine stopped, if attached.
 - c. Chocked front and rear of tires.
 - d. Ground boards emplaced.

END OF TASK**CLEANING INSTRUCTIONS****WARNING**

Improper cleaning methods and use of unauthorized cleaning liquids or solvents can injure personnel and damage equipment.

CAUTION

Do not use high-pressure water or steam to clean semitrailer. Use only low-pressure water and bristled brushes. Be especially careful when cleaning electrical system components to include lighting. Damage or impaired operation will result if this caution is not observed.

1. General.

Cleaning instructions will be the same for a majority of parts and components that make up the semitrailer. The following should apply to all cleaning operations:

- a. Clean all parts before inspection, after repair, and before assembly.
- b. Keep hands free of grease which can collect dust, dirt, and grit.
- c. After cleaning, all parts should be covered or wrapped to protect them from dust and dirt. Parts that are subject to rust should be lightly oiled.

2. Castings, Forgings, and Machined Metal Parts.**WARNING**

Solvent cleaning compound MIL-PRF-680 Type III is an environmentally compliant and low toxic material. However, it may be irritating to the eyes and skin. Use protective gloves and goggles. Use in well-ventilated areas. Keep away from open flames and other sources of ignition. Failure to follow this warning may cause injury or death to personnel.

- a. Clean inner and outer surfaces with solvent cleaning compound.
- b. Remove grease and accumulated deposits with a stiff bristle brush.

CLEANING INSTRUCTIONS - CONTINUED**WARNING**

Particles blown by compressed air are hazardous. DO NOT exceed 15 psi (103 kPa) nozzle pressure when drying parts with compressed air. Use a maximum of 30 psi (207 kPa) when cleaning components. DO NOT direct compressed air against human skin. To prevent injury, user must wear protective goggles or face shield. Make sure air stream is directed away from user and other personnel in the area. Failure to follow this warning may result in injury to personnel.

c. Clear all threaded holes with compressed air to remove dirt and cleaning fluids.

3. Grease Seals, Electrical Cables, and Flexible Hoses.**CAUTION**

Do not wash grease seals, electrical harnesses, and flexible hoses with solvent cleaning compound or mineral spirits. Serious damage or destruction of material would result.

Wash electrical cables and flexible hoses with a solution of detergent and water and wipe dry with clean rags.

4. Bearings.

Clean bearings in accordance with TM 9-214.

END OF TASK**INSPECTION INSTRUCTIONS****NOTE**

All damaged areas should be marked for repair or replacement.

All components and parts must be carefully checked to determine if they are serviceable for use, can be repaired, or must be scrapped.

1. Inspect drilled and tapped (threaded) holes for the following:
 - a. Wear, distortion, cracks, and any other damage in or around hole.
 - b. Threaded areas for wear, distortion (stretching), and evidence of cross-threading.
2. Inspect metal lines, flexible lines (hoses), and metal fittings for the following:
 - a. Metal lines for sharp kinks, cracks, bad bends, and dents.
 - b. Flexible lines for fraying, evidence of leakage, and loose metal fittings or connectors.
 - c. Metal fittings and connectors for thread damage and worn or rounded hex heads.
3. Inspect castings, forgings, and machined metal parts for the following:
 - a. Machined surfaces for nicks, burrs, raised metal, wear, and other damage.
 - b. Inner and outer surfaces for breaks and cracks.
4. Inspect bearings in accordance with TM 9-214.

END OF TASK

REPAIR INSTRUCTIONS

Any repair procedure peculiar to a specific part or component is covered in the section relating to that item. After repair, clean all parts thoroughly to prevent dirt, metal chips, or other foreign material from entering any working parts.

1. Repair casting, forgings, and machined metal parts using the following instructions:
 - a. Repair minor cracked casting or forgings in accordance with TB 9-2510-242-40.

WARNING

Solvent cleaning compound MIL-PRF-680 Type III is an environmentally compliant and low toxic material. However, it may be irritating to the eyes and skin. Use protective gloves and goggles. Use in well-ventilated areas. Keep away from open flames and other sources of ignition. Failure to follow this warning may cause injury or death to personnel.

- b. Repair minor damage to machined surfaces with a fine mill file or an abrasive cloth dipped in cleaning compound.
 - c. Replace any deeply nicked machined surface that could affect the assembly operation.
 - d. Repair minor damage to threaded capscrew holes with thread tap of same size to prevent cutting oversize.
2. After repair, clean all parts thoroughly to prevent dirt, metal chips, or other foreign material from entering any working parts.

END OF TASK

TAGGING WIRES AND HOSES

1. As soon as the first wire, hose, or tube is disconnected, write number "1" on two tags. Secure one tag to the wire, hose, or tube and the other tag to the terminal, nipple, or fitting. After disconnecting the second wire, hose, or tube, write number "2" on two tags. Secure one tag to the wire, hose, or tube, and the second tag to the terminal, nipple, or fitting. Do the same for all wires, hoses, and tubes.
2. Note which numbers you used, in pencil, on the illustrations in this manual. This will help you to accurately re-tag, if tags are removed to perform cleaning and maintenance work.
3. Remove all tags when finished.

END OF TASK

CORROSION PROTECTION

1. **General Instructions.**
 - a. To ensure a long operational life for the semitrailer, the following is presented to assist maintenance personnel. This is not meant to supersede or replace current support operations or authorized publications. Worldwide operations present many environmental impacts on the semitrailer from salt water to ice/snow melt chemicals.
 - b. Areas of conflict have their own ways of ventilating and damaging the semitrailer. All these impacts add up to shortened operational life.
2. **Tips.**
 - a. Keep the semitrailer clean, which will allow for more complete inspection of welds and components. Use low-pressure water, cleaning detergent, and brushes for cleaning.
 - b. Flush out undercarriages, suspensions, and wheel ends with clean, low-pressure water if operating in a salt environment, especially fording, as soon as the mission allows.
 - c. Keep debris out of wheel ends and twistlock pockets.
 - d. Annually clean deck wood and roll/spray on boiled linseed oil or a good commercial UV wood protector. Apply to top areas of deck wood.

CORROSION PROTECTION - CONTINUED

- e. Protect all exterior areas from rust—clean off rust, prime metal, and paint area.
- f. Application of 10 wt. oil at oil can points as specified by WP 0067 will help protect components and ensure they will work when needed.
- g. Keep bolster plate drain holes free of grease and debris so they drain/air out freely to prevent interior corrosion.

3. Corrosion Protection.

If paint has worn off or damage/repair has taken it off the undercarriage, frame, fillets, gussets, or any other protected area, re-coat with rust inhibitor and CARC paint.

4. Kingpin and Bolster Plate.

If the kingpin is replaced, inspect the interior structure for rust. Clean and protect the interior with rust inhibitor; do not plug up bolster plate drain holes. Make sure all welds are protected inside and out. Inspect the kingpin and bolster plate in accordance with PMCS requirements.

5. Protection Scheduling.

It is a good idea to periodically take a look at the paint, especially after off-road operations. The following is suggested:

- a. Monthly: Examine the condition of the paint.
- b. Annually: Clean rusted area down to bare metal. Apply rust inhibitor and top coat with CARC paint.

If operating in a salt or road chemical environment, you should wash semitrailer with clean, low-pressure water, dry, prime, and paint unprotected areas if conditions permit.

END OF TASK

ELECTRICAL SCHEMATIC

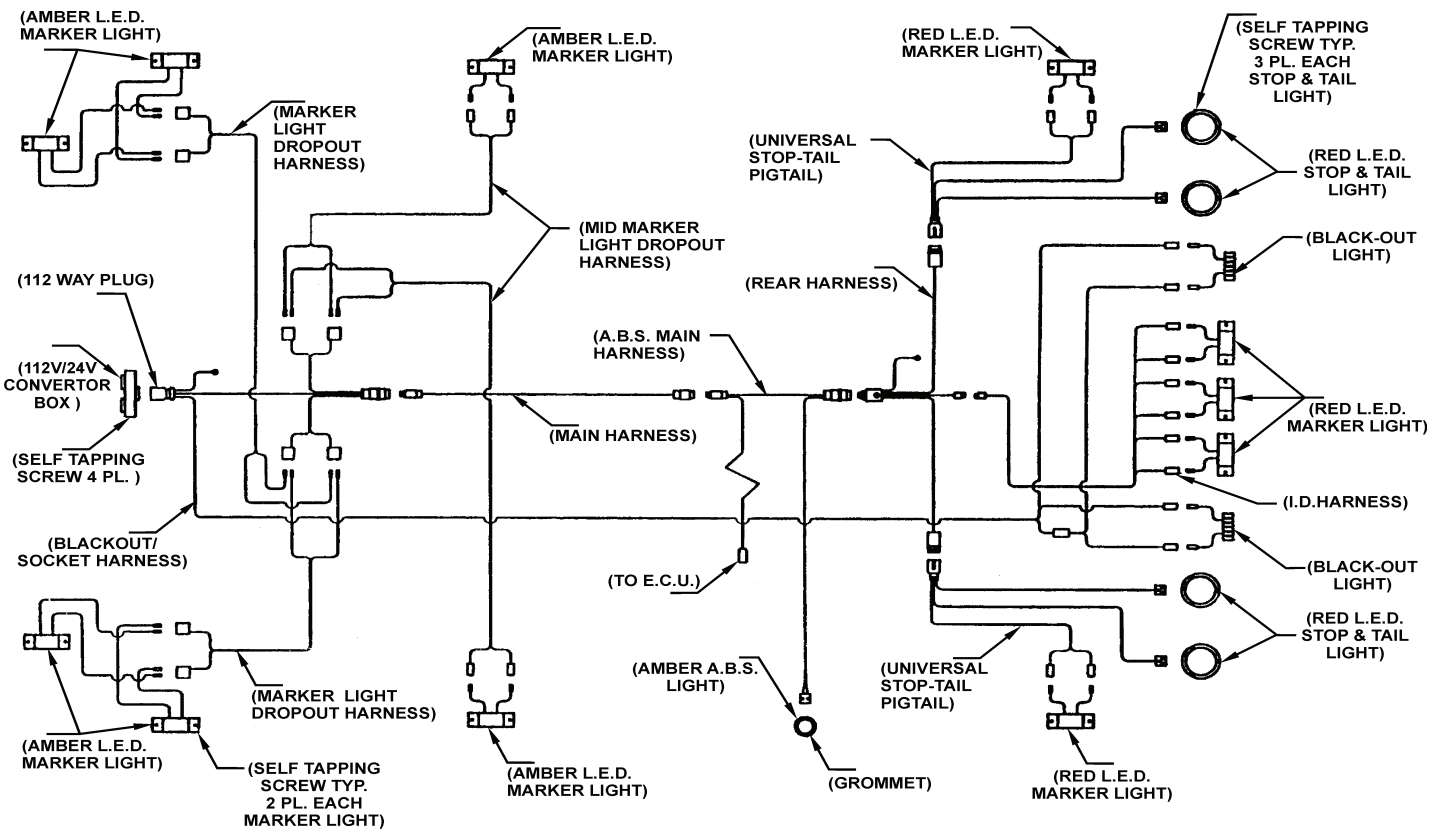

ELECTRICAL SCHEMATIC

447-0047

END OF TASK

END OF WORK PACKAGE

0023-6

ORGANIZATIONAL MAINTENANCE**WIRE CONNECTORS REPAIR****Male Connector Repair, Female Connector Repair, Terminal Replacement, Circuit Marker Band Replacement**

INITIAL SETUP**Maintenance Level**

Organizational

Materials/Parts

Insulating varnish, electrical (Item 8, WP 0085)

Tools and Special Tools

Tool kit, general mechanic's (Item 4, WP 0082)

Shop equipment, common No. 1 (Item 1, WP 0082)

WARNING

Disconnect electrical power source before performing any maintenance on the electrical system. Failure to comply could result in injury to personnel.

NOTE

If necessary, slide marker bands away from the connector.

MALE CONNECTOR REPAIR

1. Slide shell (Figure 1, Item 1) up wire lead (Figure 1, Item 2) until clear of contact (Figure 1, Item 3) and slotted washer (Figure 1, Item 4).
2. Remove slotted washer (Figure 1, Item 4).
3. Slide shell (Figure 1, Item 1) off over contact (Figure 1, Item 3).

NOTE

If replacing shell only, skip steps 4, 5, and 7.

4. Cut wire lead (Figure 1, Item 2) as close as possible to contact (Figure 1, Item 3).
5. Strip insulation from wire lead (Figure 1, Item 2) equal to depth of new contact (Figure 1, Item 3).
6. Slide new shell (Figure 1, Item 1) on wire lead (Figure 1, Item 2).
7. Slide wire lead (Figure 1, Item 2) end in new contact (Figure 1, Item 3). Crimp contact to wire lead. Apply insulating compound to wire lead.
8. Place slotted washer (Figure 1, Item 4) on wire lead (Figure 1, Item 2) at contact (Figure 1, Item 3).
9. Slide shell (Figure 1, Item 1) down wire lead (Figure 1, Item 2) until slotted washer (Figure 1, Item 4) seats.

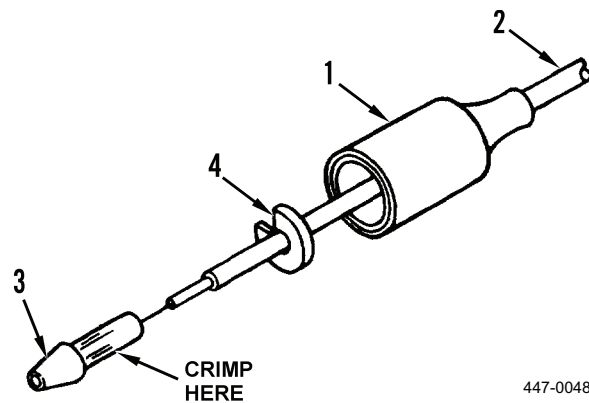

Figure 1. Male Connector.

10. Apply insulating compound to outside of female connector shell. Push connector halves together until seated.
11. Connect power. Test semitrailer lights for proper operation.

END OF TASK

FEMALE CONNECTOR REPAIR

1. Slide shell (Figure 2, Item 5) and insulator (Figure 2, Item 6) up wire lead (Figure 2, Item 7) until clear of terminal (Figure 2, Item 8).
2. Cut wire lead (Figure 2, Item 7) as close as possible to terminal (Figure 2, Item 8).
3. Slide insulator (Figure 2, Item 6) and shell (Figure 2, Item 5) off wire lead (Figure 2, Item 7).
4. Strip insulation from wire lead (Figure 2, Item 7) 1/8 in. from end.
5. Slide shell (Figure 2, Item 5) and insulator (Figure 2, Item 6) on wire lead (Figure 2, Item 7).
6. Slide wire lead (Figure 2, Item 7) end in terminal (Figure 2, Item 8). Crimp terminal to wire lead. Apply insulating compound to end of wire lead.
7. Slide insulator (Figure 2, Item 6) and shell (Figure 2, Item 5) over terminal (Figure 2, Item 8) until seated.
8. Apply insulating compound to outside of female connector shell (Figure 2, Item 5). Push connector halves together until seated.

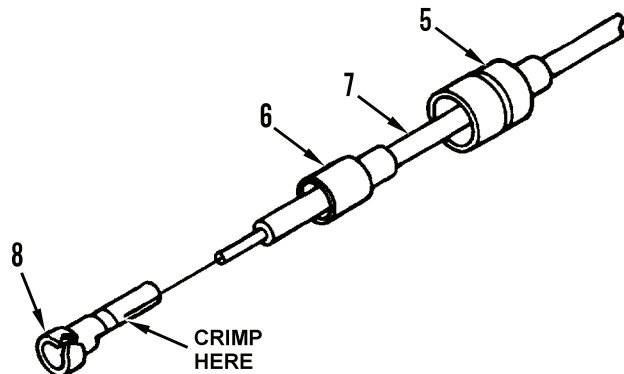

447-0049

Figure 2. Female Connector.

9. Connect power. Test semitrailer lights for proper operation.

END OF TASK

TERMINAL REPLACEMENT**NOTE**

This procedure is typical for ring-type and quick-disconnect terminals. Procedure shown is for ring (grounding) terminal.

1. Cut wire lead (Figure 3, Item 9) as close as possible to terminal (Figure 3, Item 10). Discard terminal.
2. Strip insulation from wire lead (Figure 3, Item 9) equal to depth of new terminal (Figure 3, Item 10).
3. Slide wire lead (Figure 3, Item 9) end in new terminal (Figure 3, Item 10). Crimp terminal to wire lead.
4. Connect terminal.
5. Connect power. Test semitrailer lights for proper operation.

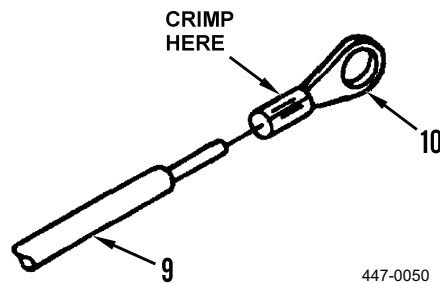

Figure 3. Terminal.

END OF TASK**CIRCUIT MARKER BAND REPLACEMENT**

1. Using flat-tip screwdriver, open tab ends (Figure 4, Item 11) on marker band (Figure 4, Item 12). Remove from wire lead (Figure 4, Item 13), note circuit number, and discard marker band.
2. Etch proper number on new marker band (Figure 4, Item 12).
3. Place new circuit marker band (Figure 4, Item 12) on wire lead (Figure 4, Item 13). Bend tab ends (Figure 4, Item 11) over wire lead.

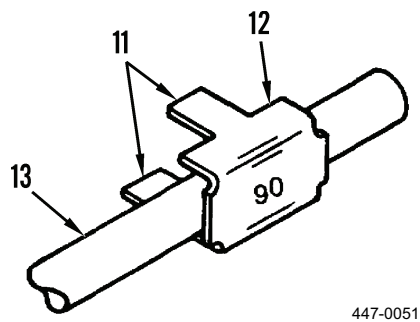

Figure 4. Circuit Marker Band.

4. Connect power.

END OF TASK**END OF WORK PACKAGE**

ORGANIZATIONAL MAINTENANCE
BLACKOUT LIGHTS REPLACEMENT
Removal, Installation

INITIAL SETUP**Maintenance Level**

Organizational

ReferencesElectrical schematic (WP 0023)
WP 0093**Tools and Special Tools**

Tool kit, general mechanic's (Item 4, WP 0082)

Equipment ConditionsLanding legs down
Semitrailer disconnected from prime mover
Tires chocked
Ground boards emplaced**Materials/Parts**Grease, dielectric (silicone) (Item 7, WP 0085)
Lockwasher (4)

WARNING

Disconnect electrical power source before performing any maintenance on the electrical system. Failure to comply could result in injury to personnel.

NOTE

- Right and left blackout lights are removed and installed the same way. This procedure covers one blackout light.
- See WP 0093 for technical data on lighting.

REMOVAL

1. Disconnect two connectors.
2. Remove two nuts (Figure 1, Item 3), lockwashers (Figure 1, Item 2), and blackout light (Figure 1, Item 1). Discard lockwashers.

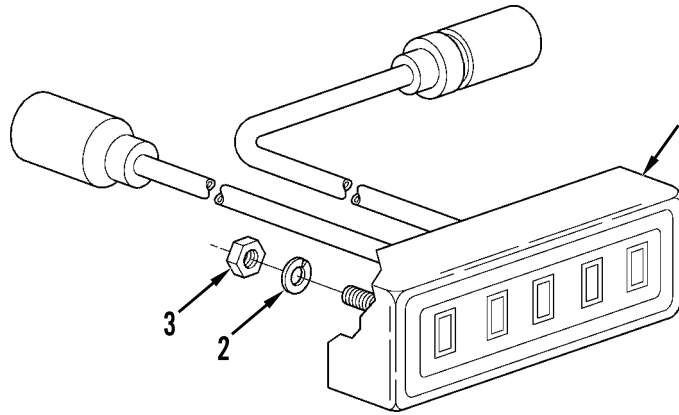

Figure 1. Blackout Lights.

END OF TASK**INSTALLATION**

1. Install blackout light (Figure 1, Item 1), two new lockwashers (Figure 1, Item 2), and nuts (Figure 1, Item 3).
2. Apply dielectric grease on pins and then connect two connectors.

END OF TASK**FOLLOW-ON TASKS**

1. Connect semitrailer to prime mover.
2. Raise landing legs.
3. Remove/store chocks and ground boards.
4. Connect power source and test blackout lights for proper operation.

END OF TASK**END OF WORK PACKAGE**

ORGANIZATIONAL MAINTENANCE
CLEARANCE LIGHTS REPLACEMENT
Removal, Installation

INITIAL SETUP**Maintenance Level**

Organizational

Tools and Special Tools

Tool kit, general mechanic's (Item 4, WP 0082)

Materials/Parts

Antiseize compound (Item 1, WP 0085)
Grease, dielectric (silicone) (Item 7, WP 0085)
Screw, self-tapping (20)

References

Electrical schematic (WP 0023)
WP 0093

Equipment Conditions

Landing legs down
Semitrailer disconnected from prime mover
Tires chocked
Ground boards emplaced

WARNING

Disconnect electrical power source before performing any maintenance on the electrical system. Failure to comply could result in injury to personnel.

NOTE

- There are nine clearance lights on the semitrailer. The two front clearance lights (Figure 1, Item 2) are held in place with three self-tapping screws. The seven remaining side and rear clearance lights (Figure 1, Item 1) use two self-tapping screws each. This procedure removes and installs one front clearance light; the remaining clearance lights are removed and installed the same way.
- See WP 0093 for technical data on lighting.

REMOVAL

1. Disconnect wiring harness from clearance light connector behind bulkhead.
2. Remove self-tapping screws (Figure 1, Item 3) and clearance light (Figure 1, Item 1 or 2). Discard screws.

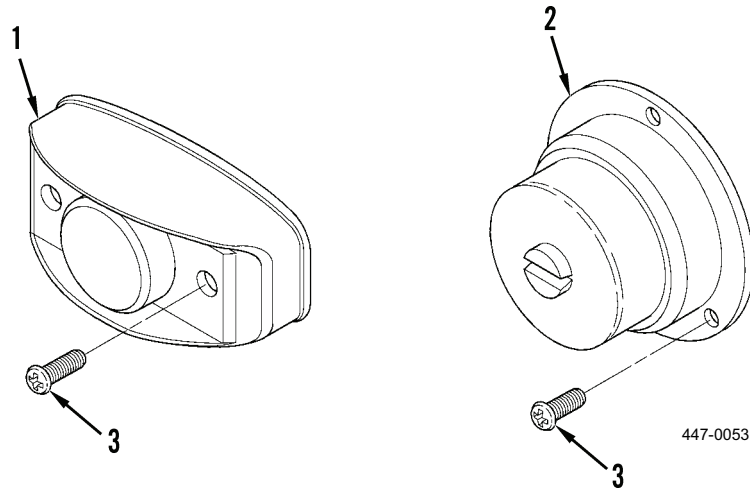

Figure 1. Clearance Lights.

END OF TASK**INSTALLATION**

1. Apply antiseize compound to self-tapping screws. Install clearance light (Figure 1, Item 1 or 2) and three new self-tapping screws (Figure 1, Item 3).
2. Apply dielectric grease to wiring harness pins. Connect wiring harness connector to clearance light connector behind bulkhead.

END OF TASK**FOLLOW-ON TASKS**

1. Connect semitrailer to prime mover.
2. Raise landing legs.
3. Connect power source and test clearance lights for proper operation.

END OF TASK**END OF WORK PACKAGE**

ORGANIZATIONAL MAINTENANCE**LED TAILLIGHTS REPLACEMENT****Removal, Installation**

INITIAL SETUP**Maintenance Level**

Organizational

Tools and Special Tools

Tool kit, general mechanic's (Item 4, WP 0082)

Materials/Parts

Antiseize compound (Item 1, WP 0085)

Grease, dielectric (silicone) (Item 7, WP 0085)

Screw, self-tapping (12)

References

Electrical schematic (WP 0023)

WP 0093

Equipment Conditions

Landing legs down

Semitrailer disconnected from prime mover

Tires chocked

Ground boards emplaced

WARNING

Disconnect electrical power source before performing any maintenance on the electrical system. Failure to comply could result in injury to personnel.

NOTE

- There are four taillights and they are removed and installed the same way. This procedure covers one taillight.
- See WP 0093 for technical data on lighting.

REMOVAL**NOTE**

Only the two outer taillights have ground wires.

1. Disconnect taillight connector from wiring harness connector behind bulkhead.
2. Disconnect ground wire from taillight behind bulkhead, if necessary.
3. Remove three self-tapping screws (Figure 1, Item 2) and taillight (Figure 1, Item 1). Discard screws.

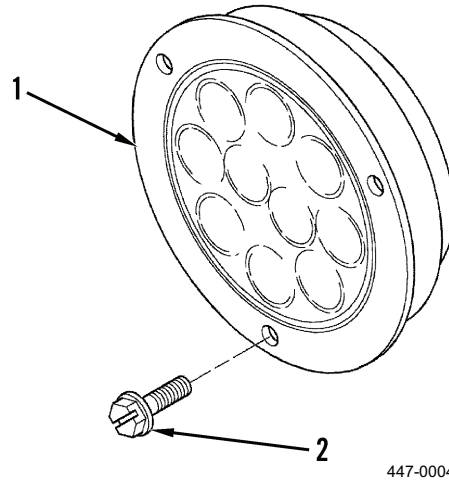

Figure 1. Taillight.

END OF TASK**INSTALLATION**

1. Use a light coat of antiseize compound on screws. Install taillight (Figure 1, Item 1) with three new self-tapping screws (Figure 1, Item 2).
2. Connect ground wire to taillight, if necessary.
3. Use dielectric grease on pins. Connect taillight connector to wiring harness connector behind bulkhead.

END OF TASK**FOLLOW-ON TASKS**

1. Connect semitrailer to prime mover.
2. Raise landing legs.
3. Remove/store chocks and ground boards.
4. Connect power source and test taillights for proper operation.

END OF TASK**END OF WORK PACKAGE**

ORGANIZATIONAL MAINTENANCE**RECEPTACLE CONVERTER BOX REPLACEMENT (M871R AND M871A1R)****Removal, Installation**

INITIAL SETUP**Maintenance Level**

Organizational

ReferencesElectrical Schematic (WP 0023)
WP 0089**Tools and Special Tools**

Tool kit, general mechanic's (Item 4, WP 0082)

Equipment ConditionsLanding legs down
Semitrailer disconnected from prime mover
Tires chocked
Ground boards emplaced**Materials/Parts**Grease, dielectric (silicone) (Item 7, WP 0085)
Screw, self-tapping (4)

WARNING

Disconnect electrical power source before performing any maintenance on the electrical system. Failure to comply could result in injury to personnel.

CAUTION

The semitrailer's converter box and electrical system will be damaged if the 12 V (7 pin) and 24V (12 pin) cables are plugged in at the same time. Do not plug both the 12V (7 pin) and 24V (12 pin) cables in at the same time. Failure to comply may result in equipment damage.

NOTE

See WP 0089 for technical data on the receptacle converter box.

REMOVAL

1. Remove four self-tapping screws (Figure 1, Item 1) and pull out receptacle converter box (Figure 1, Item 2) from semitrailer. Discard self-tapping screws.

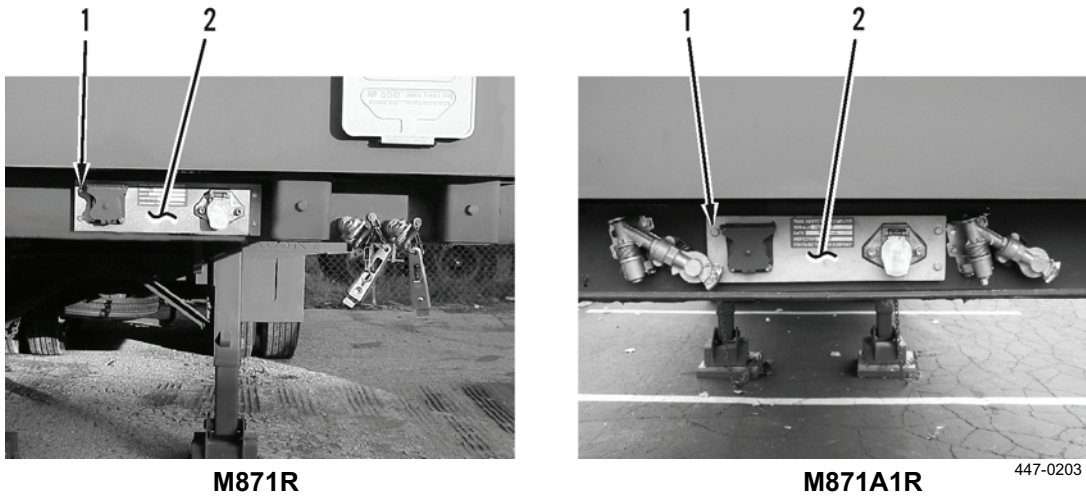
**Figure 1. Receptacle Converter Box.**

2. Disconnect cable (Figure 2, Item 3) from semitrailer wiring harness and remove receptacle converter box (Figure 2, Item 2) from semitrailer.
3. Remove cable (Figure 2, Item 3) from receptacle converter box (Figure 2, Item 2).

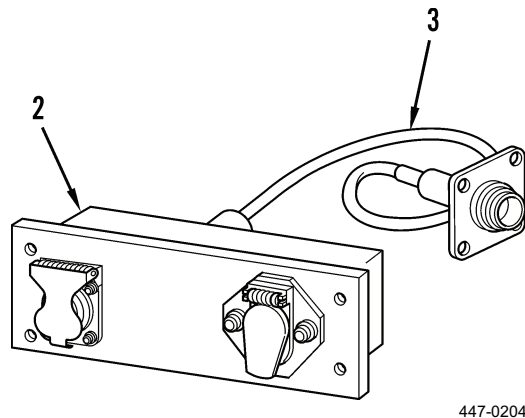
**Figure 2. Cable.****END OF TASK****INSTALLATION**

1. Install cable (Figure 2, Item 3) on receptacle converter box (Figure 2, Item 2).
2. Connect cable (Figure 2, Item 3) to semitrailer wiring harness and position receptacle converter box (Figure 2, Item 1) on semitrailer.
3. Install four new self-tapping screws (Figure 1, Item 1) securing receptacle converter box (Figure 1, Item 2) to semitrailer.

END OF TASK

FOLLOW-ON TASKS

1. Connect semitrailer to prime mover.
2. Raise landing legs.
3. Remove/store chocks and ground boards.
4. Connect power source and test receptacle converter box for proper operation.

END OF TASK**END OF WORK PACKAGE**

ORGANIZATIONAL MAINTENANCE**RECEPTACLE CONVERTER BOX AND NOSE PLATE REPLACEMENT (M871A2R)
Removal, Installation**

INITIAL SETUP**Maintenance Level**

Organizational

Tools and Special Tools

Tool kit, general mechanic's (Item 4, WP 0082)

Materials/Parts

Grease, dielectric (silicone) (Item 7, WP 0085)

Locknut (4)

Screw, self-tapping (6)

References

Electrical schematic (WP 0023)

WP 0089

Equipment Conditions

Landing legs down

Semitrailer disconnected from prime mover

Tires chocked

Ground boards emplaced

WARNING

Disconnect electrical power source before performing any maintenance on the electrical system. Failure to comply could result in injury to personnel.

CAUTION

The semitrailer's converter box and electrical system will be damaged if the 12V (7 pin) and 24V (12 pin) cables are plugged in at the same time. Do not plug both the 12V (7 pin) and 24V (12 pin) cables in at the same time. Failure to comply may result in equipment damage.

NOTE

See WP 0089 for technical data on the receptacle converter box.

REMOVAL**NOTE**

Two of the six self-tapping screws also secure the gladhands.

1. Remove six self-tapping screws (Figure 1, Item 1) and pull out nose plate (Figure 1, Item 2) as a unit. Discard self-tapping screws.

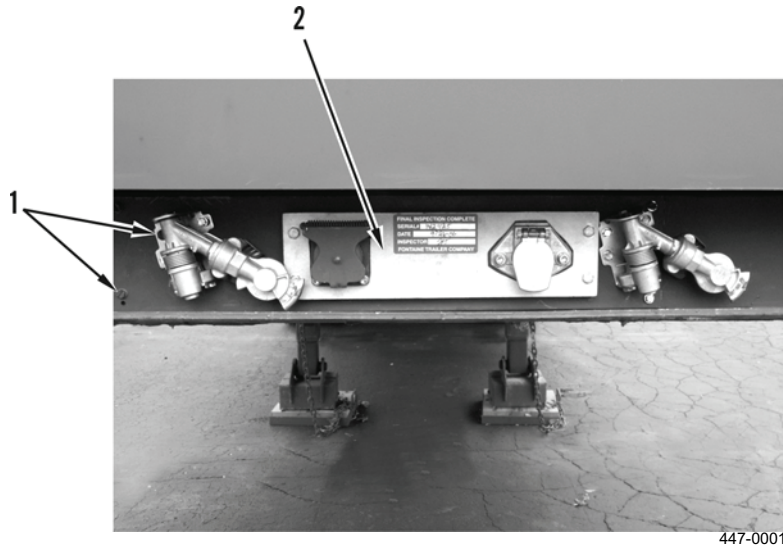

Figure 1. Nose Plate.

2. Remove nut (Figure 2, Item 8) and disconnect ground wire (Figure 2, Item 6).
3. Disconnect hoses (Figure 2, Item 3 and 7).
4. Disconnect cable (Figure 2, Item 5) from wiring harness (Figure 2, Item 4) and remove nose plate (Figure 2, Item 2) as a unit.

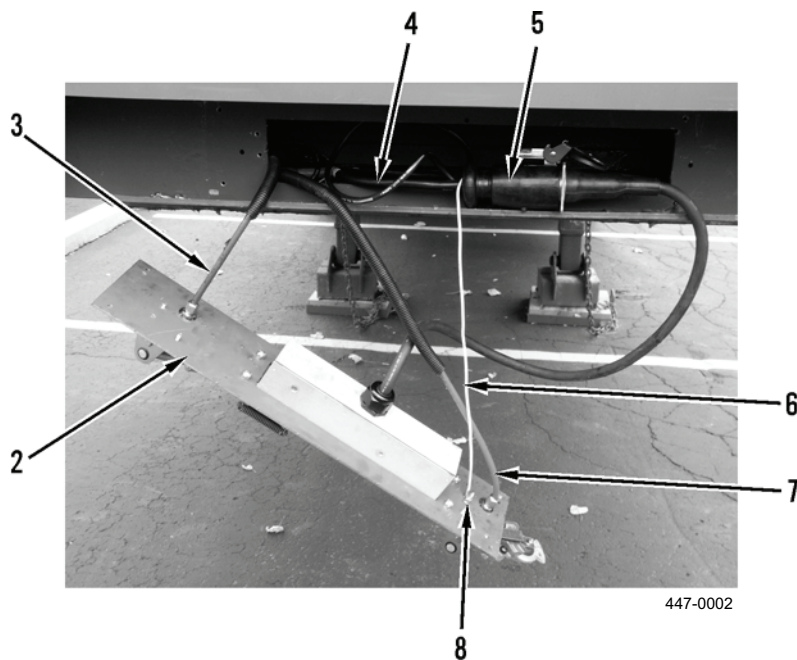

Figure 2. Ground Wire/Wiring Harness/Hoses.

REMOVAL - CONTINUED

5. Remove cable (Figure 3, Item 5) from receptacle converter box (Figure 3, Item 9).
6. Remove four locknuts (Figure 3, Item 10), bolts (Figure 3, Item 11), and receptacle converter box (Figure 3, Item 9) from nose plate (Figure 3, Item 2). Discard locknuts.

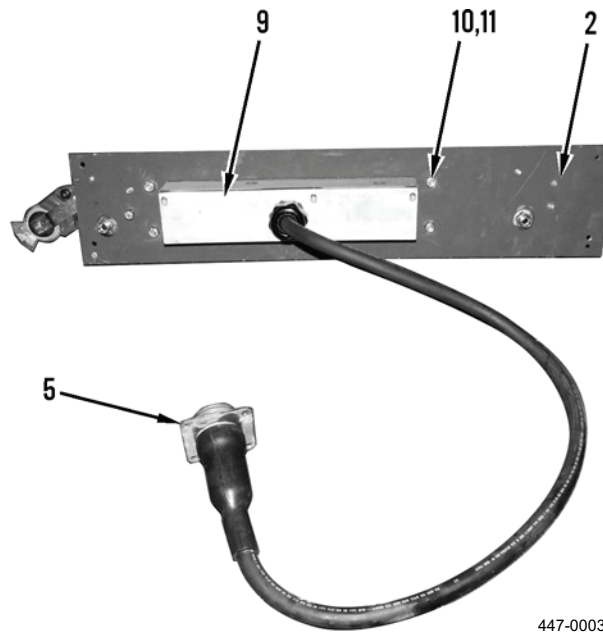

Figure 3. Receptacle Converter Box and Cable.

END OF TASK**INSTALLATION**

1. Install receptacle converter box (Figure 3, Item 9), four bolts (Figure 3, Item 11), and new locknuts (Figure 3, Item 10) on nose plate (Figure 3, Item 2).
2. Install cable (Figure 3, Item 5) on receptacle converter box (Figure 3, Item 9).
3. Connect cable (Figure 2, Item 5) to wiring harness (Figure 2, Item 4).
4. Connect hoses (Figure 2, Items 7 and 3) if disconnected.
5. Connect ground wire (Figure 2, Item 6) and install nut (Figure 2, Item 8).
6. Install nose plate (Figure 1, Item 2) as a unit and install six new self-tapping screws (Figure 1, Item 1).

END OF TASK**FOLLOW-ON TASKS**

1. Connect semitrailer to prime mover.
2. Raise landing legs.
3. Remove/store chocks and ground boards.
4. Connect power source and test receptacle converter box for proper operation.

END OF TASK**END OF WORK PACKAGE**

ORGANIZATIONAL MAINTENANCE
WIRING HARNESSES REPLACEMENT
Removal, Installation

INITIAL SETUP**Maintenance Level**

Organizational

Tools and Special Tools

Tool kit, general mechanic's (Item 4, WP 0082)

Materials/Parts

Grease, dielectric (silicone) (Item 7, WP 0085)

ReferencesElectrical schematic (WP 0023)
WP 0029**References - Continued**WP 0041
WP 0105**Equipment Conditions**Landing legs down
Semitrailer disconnected from prime mover
Electrical power disconnected from semitrailer
Tires chocked
Ground boards emplaced

WARNING

Disconnect electrical power source before performing any maintenance on the electrical system. Failure to comply could result in injury to personnel.

CAUTION

Use dielectric grease on all electrical connection(s) and grounds to prevent corrosion. Failure to comply may result in damage to equipment.

NOTE

See WP 0105 for technical data on ABS/ECU brake system.

REMOVAL (REAR TO FRONT)

1. Remove two wiring harnesses (Figure 1, Item 1) from taillights, side clearance lights, and rear wiring harness (Figure 1, Item 4).
2. Remove wiring harness (Figure 1, Item 2) from two BO lights and BO socket wiring harness (Figure 1, Item 6).
3. Remove wiring harness (Figure 1, Item 3) from rear clearance lights and rear wiring harness (Figure 1, Item 4).
4. Remove ABS main wiring harness (Figure 1, Item 5) from ABS warning light, rear wiring harness (Figure 1, Item 4), and main wiring harness (Figure 1, Item 10).

NOTE

Excess wire is stored in left-front underside pocket (refer to WP 0041, Figure 1) for M871R.
 Excess wire is stored in receptacle converter box compartment (refer to WP 0028, Figure 1) for M871A1R. Excess wire is stored in nose plate box compartment (refer to WP 0029, Figure 1) for M871A2R.

5. Remove midturn ABS wiring harness (Figure 1, Item 7) from two midside clearance lights and main wiring harness (Figure 1, Item 10).
6. Remove two PL10 wiring harnesses (Figure 1, Item 9) from front clearance lights and two PL10 marker wiring harnesses (Figure 1, Item 8).
7. Remove two PL10 marker wiring harnesses (Figure 1, Item 8) from BO socket wiring harness (Figure 1, Item 6).
8. Remove BO socket wiring harness (Figure 1, Item 6) and main wiring harness (Figure 1, Item 10).
9. Remove damaged grommets (Figure 1, Items 11 thru 13), as necessary.

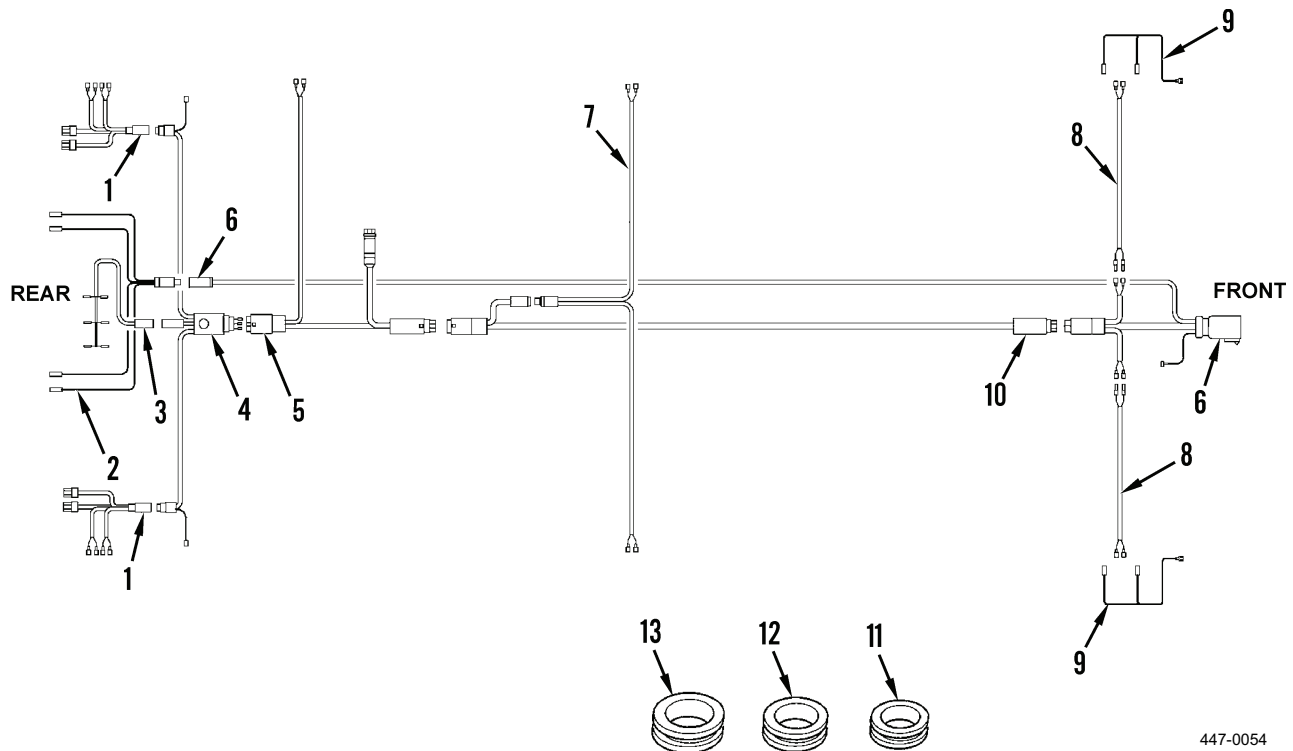

Figure 1. Wiring Harnesses.

END OF TASK

INSTALLATION**NOTE**

Excess wire is stored in left-front underside pocket (refer to WP 0041, Figure 1) for M871R. Excess wire is stored in receptacle converter box compartment (refer to WP 0028, Figure 1) for M871A1R. Excess wire is stored in nose plate box compartment (refer to WP 0029, Figure 1) for M871A2R.

1. Replace any damaged grommets (Figure 1, Items 11 thru 13), as necessary.

NOTE

Use dielectric grease on all pins.

2. Install BO socket wiring harness (Figure 1, Item 6) and main wiring harness (Figure 1, Item 10).
3. Install two PL10 marker wiring harnesses (Figure 1, Item 8) to BO socket wiring harness (Figure 1, Item 6).
4. Install two PL10 wiring harnesses (Figure 1, Item 9) to two front marker lights and two PL10 marker wiring harnesses (Figure 1, Item 8).
5. Install midturn ABS wiring harness (Figure 1, Item 7) to two midside clearance lights and main wiring harness (Figure 1, Item 10).
6. Install ABS main wiring harness (Figure 1, Item 5) to ABS warning light, rear wiring harness (Figure 1, Item 4), and main wiring harness (Figure 1, Item 10).
7. Install wiring harness (Figure 1, Item 3) to rear clearance lights and rear wiring harness (Figure 1, Item 4).
8. Install wiring harness (Figure 1, Item 2) to two BO lights and BO light wiring harness (Figure 1, Item 6).
9. Install two wiring harnesses (Figure 1, Item 1) to taillights, side clearance lights, and rear wiring harness (Figure 1, Item 4).

END OF TASK**FOLLOW-ON TASKS**

1. Connect semitrailer to prime mover.
2. Raise landing legs.
3. Remove/store chocks and ground boards.
4. Check to ensure lighting system is operational.

END OF TASK**END OF WORK PACKAGE**

ORGANIZATIONAL MAINTENANCE
SERVICE BRAKES - S-CAMSHAFT REPLACEMENT
Removal, Installation

INITIAL SETUP**Maintenance Level**

Organizational

References

WP 0067

WP 0107

Tools and Special Tools

Tool kit, general mechanic's (Item 4, WP 0082)

Jack stands

Equipment Conditions

Semitrailer disconnected from prime mover

Axles supported by jack stands

Tires and wheels removed (WP 0021)

Brake drum removed (WP 0033)

Brake shoes removed (WP 0032)

Materials/PartsGrease, automotive and artillery (GAA)
(Item 6, WP 0085)

Lockwasher (4)

O-ring (2)

Retaining ring

WARNING

- Before performing any work on the spring brake system, chock the wheels front and rear to prevent semitrailer movement. Failure to follow this warning may result in injury or death to personnel.
- All brake chambers must be caged before working on the brake system to prevent serious injury to personnel and damage to equipment.
- The axle must be firmly supported to prevent shifting of the semitrailer. Shifting may cause serious injury to personnel and damage to equipment.
- Clean and check all S-camshaft brake components for wear and damage. Replace worn or damaged parts. At Triennial Service replace all O-rings, bushings, retainers, snap rings, lockwashers, and brackets on each axle end. Failure to comply could cause injury to personnel and damage to equipment.

NOTE

- There are four brake S-camshafts (two left and two right) and they are removed and installed the same way. Right and left does not mean left and/or right side. Left or right S-camshaft is specific to S-camshaft rotation in operation (see WP 0107). This procedure covers one brake S-camshaft.
- S-camshafts and related parts are to be lubricated in accordance with WP 0067.

REMOVAL

1. Remove snap ring (Figure 1, Item 7) and retaining ring (Figure 1, Item 8) from S-camshaft (Figure 1, Item 1). Discard retaining ring.
2. Remove S-camshaft (Figure 1, Item 1), washer (Figure 1, Item 2), two washers (Figure 1, Item 3), washer (Figure 1, Item 6), spacer (Figure 1, Item 10), and washer (Figure 1, Item 9) from bushing retainer (Figure 1, Item 4).
3. Remove four screws (Figure 1, Item 5) and bushing retainer (Figure 1, Item 4).
4. Remove four screws (Figure 1, Item 11), lockwashers (Figure 1, Item 12), washers (Figure 1, Item 13), retainer bushing (Figure 1, Item 15), bushing bracket (Figure 1, Item 17), two O-rings (Figure 1, Item 16), and retainer bushing (Figure 1, Item 18). Discard lockwashers and O-rings. Check for worn bushings.
5. Remove lubrication fitting (Figure 1, Item 14) from retainer bushing (Figure 1, Item 15).

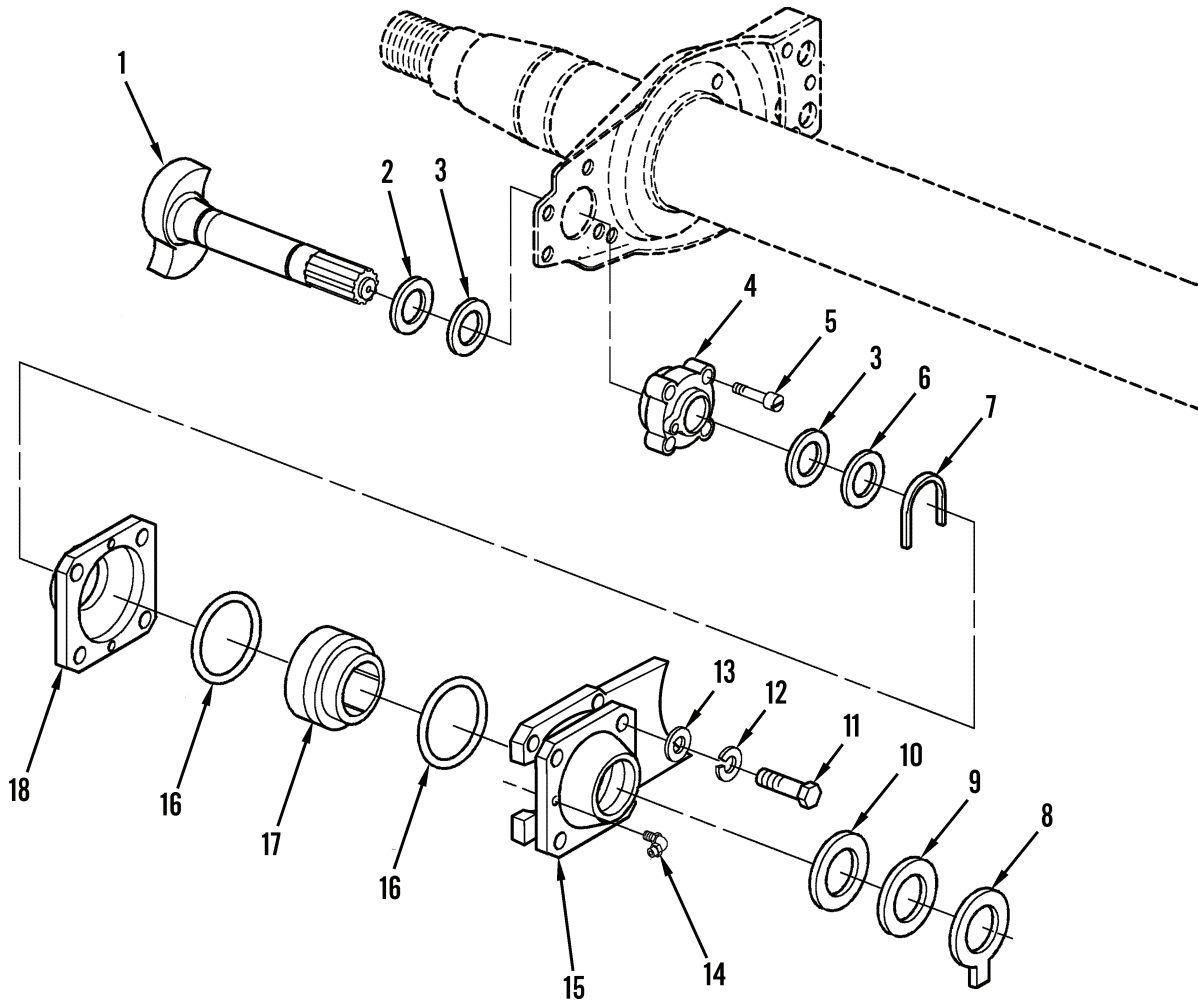

447-0055

Figure 1. Service Brakes - S-Camshaft.**END OF TASK**

INSTALLATION

1. Install lubrication fitting (Figure 1, Item 14) on retainer bushing (Figure 1, Item 15).
2. Lube zerk fittings (see WP 0067).
3. Install retainer bushing (18), bushing bracket (Figure 1, Item 17), two new O-rings (Figure 1, Item 16), and retainer bushing (Figure 1, Item 15) onto S-camshaft (Figure 1, Item 1) with four new lockwashers (Figure 1, Item 12), washers (Figure 1, Item 13), and screws (Figure 1, Item 11).
4. Install bushing retainer (Figure 1, Item 4) and four screws (Figure 1, Item 5).
5. Lightly lube S-camshaft lobes with GAA grease. Wipe off excess grease.
6. Install S-camshaft (Figure 1, Item 1) with washer (Figure 1, Item 2), two washers (Figure 1, Item 3), washer (Figure 1, Item 6), spacer (Figure 1, Item 10), and washer (Figure 1, Item 9).
7. Install S-camshaft (Figure 1, Item 1), snap ring (Figure 1, Item 7), and new retaining ring (Figure 1, Item 8).

END OF TASK**FOLLOW -ON TASKS**

1. Install brake shoes (WP 0032).
2. Install brake drum (WP 0033).
3. Install tire and wheel (WP 0021).
4. Remove jack stands from axles.
5. Connect semitrailer to prime mover.
6. Road test to check for safe operation.

END OF TASK**END OF WORK PACKAGE**

ORGANIZATIONAL MAINTENANCE**SERVICE BRAKES - SHOES AND LINING REPLACEMENT**
Removal, Installation, Dust Shield Removal and Installation

INITIAL SETUP**Maintenance Level**

Organizational

References

WP 0067

Tools and Special ToolsTool kit, general mechanic's (Item 4, WP 0082)
Jack stands**Equipment Conditions**Semitrailer disconnected from prime mover
Tires and wheels removed (WP 0021)
Brake drum removed (WP 0033)
Ground boards emplaced**Materials/Parts**Grease, automotive and artillery (GAA) (Item 6, WP
0085)

WARNING

Clean and check service brakes and all brake components for wear and damage. Replace worn or damaged parts. At triennial service replace all springs, pins, rollers, clips, and bushings on each axle end. Failure to comply may cause injury to personnel and damage to the equipment.

CAUTION

Do not allow lining surfaces to become contaminated with any lubrication. Failure to comply could cause damage to equipment.

NOTE

- There are four brake shoe assemblies and they are removed and installed the same way. This procedure covers one brake shoe assembly.
- Balance repairs on both axle ends.

WARNING

- Jack must be positioned directly under axle to prevent slippage. Direct all personnel to stay clear of semitrailer when semitrailer is supported in the air. Failure to comply may result in injury or death to personnel or damage to equipment.
- To prevent shifting of semitrailer, floor jack should be used only on a hard, level surface. Use ground boards, if necessary. Chock tires. Failure to comply may result in injury or death to personnel.

REMOVAL

1. Support axle on both sides with jack stands.
2. Push S-camshaft end of lower shoe and lining (Figure 1, Item 10) down. Pull lower roller retainer (Figure 1, Item 3) to remove roller (Figure 1, Item 2) and retainer.
3. Lift S-camshaft end of upper shoe and lining (Figure 1, Item 10). Pull upper roller retainer (Figure 1, Item 3) to remove top roller (Figure 1, Item 2) and retainer.
4. Lift free end of lower shoe and lining (Figure 1, Item 10) and remove return spring (Figure 1, Item 4).
5. Swing free end of lower shoe and lining (Figure 1, Item 10) away from S-camshaft to release tension on retaining springs (Figure 1, Item 11).
6. Remove two retaining springs (Figure 1, Item 11) and shoes and linings (Figure 1, Item 10).
7. Remove two anchor pins (Figure 1, Item 5).
8. Use a hammer and suitable driver to remove two bushings (Figure 1, Item 6) from spider.

REMOVAL - CONTINUED

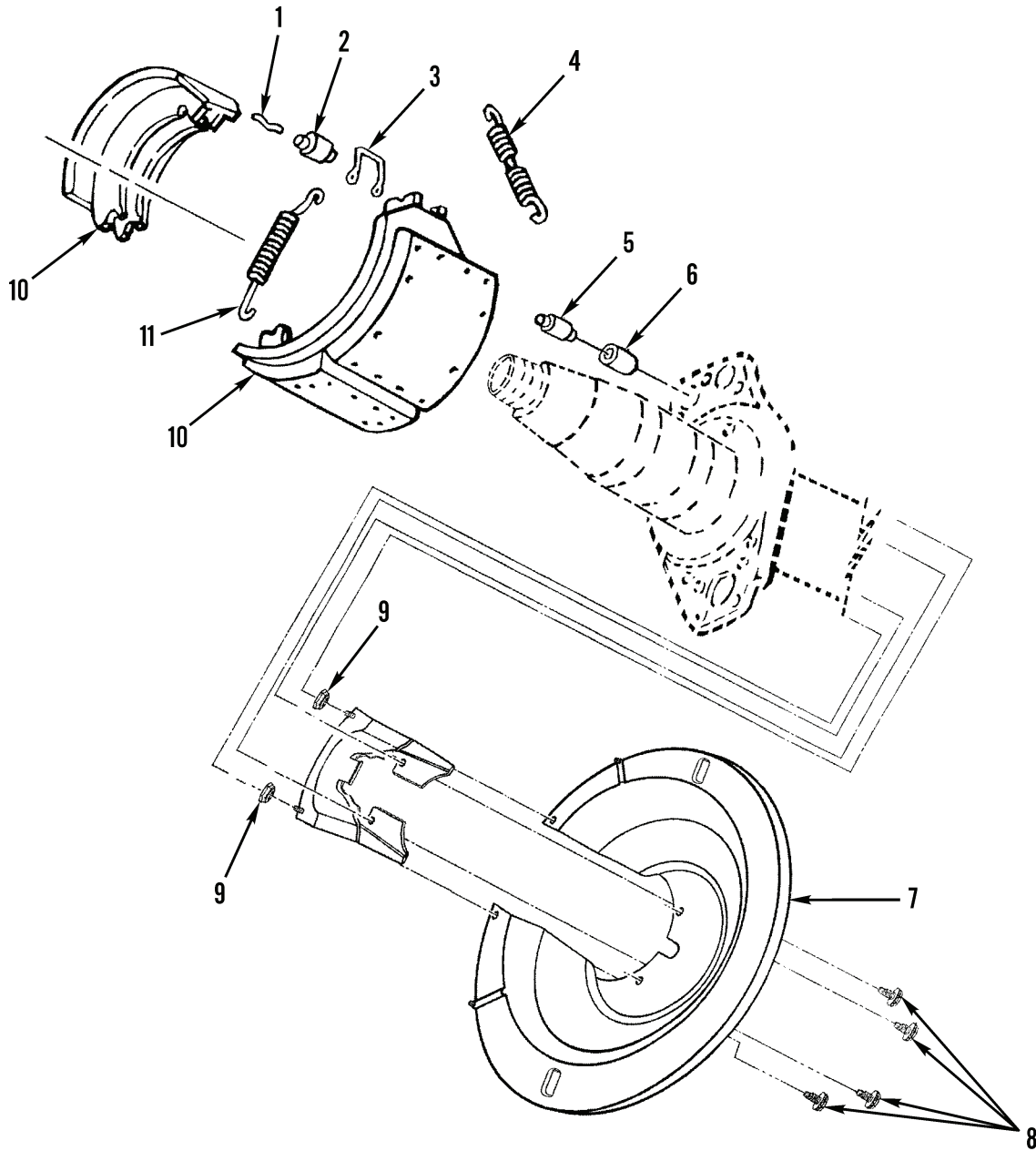

447-0056

Figure 1. Service Brakes - Shoes and Lining.

END OF TASK

INSTALLATION

1. Drive two new bushings (Figure 2, Item 6) into spider.
2. Lightly lubricate and install two new anchor pins (Figure 2, Item 5) into bushings (Figure 2, Item 6) (WP 0067).
3. Place upper shoe and lining (Figure 2, Item 10) in position on top anchor pin (Figure 2, Item 5).
4. Install new anchor pins (Figure 2, Item 2), retainers (Figure 2, Item 3), and springs (Figure 2, Items 4 and 11) at each shoe and lining replacement.
5. Hold lower shoe and lining (Figure 2, Item 10) against bottom anchor pin (Figure 2, Item 5) and install two retainer springs (Figure 2, Item 4).
6. Swing free end of lower shoe and lining (Figure 2, Item 10) to S-camshaft, pull shoe and lining up, and install return spring (Figure 2, Item 4) on both shoe and lining (Figure 2, Item 10) pins.
7. Install roller retainer (Figure 1, Item 3) on bottom roller (Figure 2, Item 2).
8. Install S-camshaft end of lower shoe and lining (Figure 1, Item 10) down.
9. Squeeze sides of roller retainer (Figure 2, Item 3) together so it fits between lower shoe and lining (Figure 2, Item 10) webs. Position bottom roller (Figure 2, Item 2) on webs and push roller retainer (Figure 2, Item 3) between shoe and lining webs until it locks into web holes.
10. Install roller retainer (Figure 2, Item 3) on top roller (Figure 2, Item 2).
11. Pull S-camshaft end of upper shoe and lining (Figure 2, Item 10) up.
12. Squeeze sides of roller retainer (Figure 2, Item 3) together so it fits between upper shoe and lining webs. Position top roller (Figure 2, Item 2) on webs and push roller retainer (Figure 2, Item 3) between shoe and lining webs.
13. Adjust automatic slack adjusters manually as required.

INSTALLATION - CONTINUED

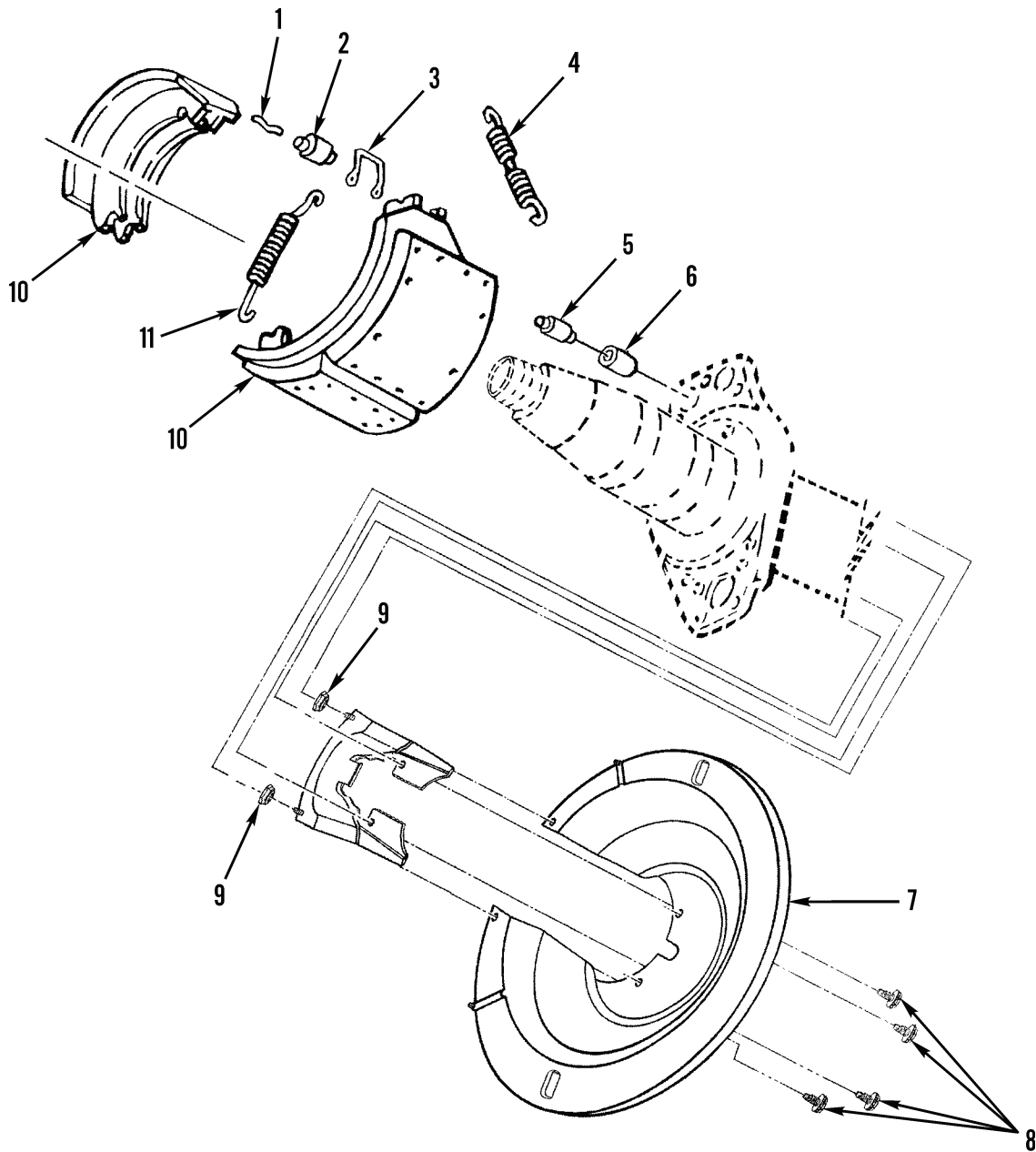

447-0056

Figure 2. Service Brakes - Shoes and Lining.

END OF TASK

DUST SHIELD REMOVAL AND INSTALLATION

1. Remove the drum or move it outboard of the brake spider.

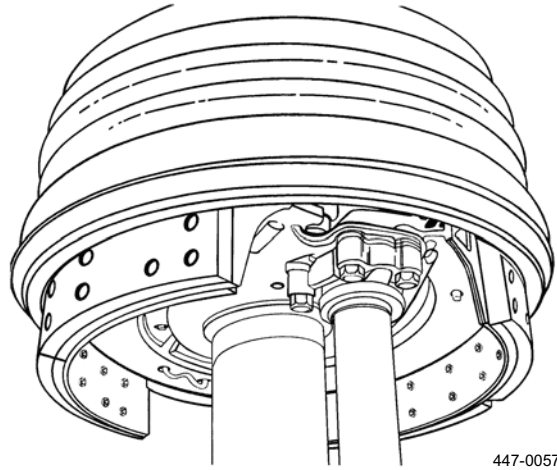

Figure 3. Drum.

2. Assemble the filler plate onto the brake spider as shown. The tab on the filler plate must be hooked over the edge of the brake spider.

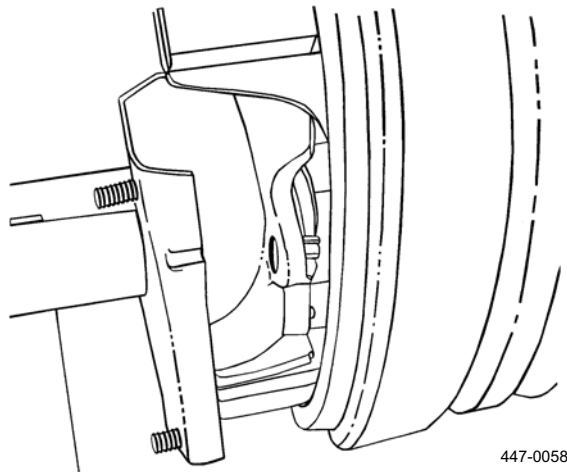
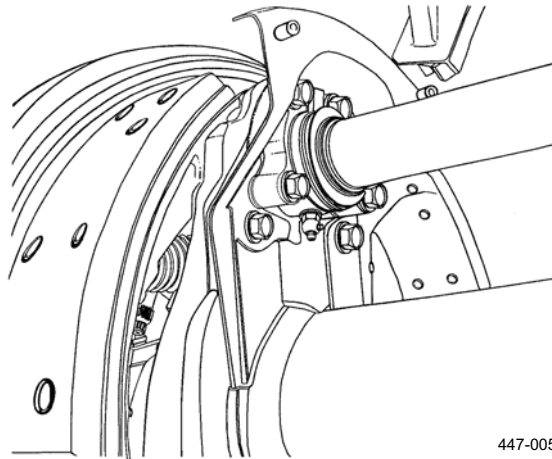

Figure 4. Filler Plate.

DUST SHIELD REMOVAL AND INSTALLATION - CONTINUED

3. Install the two self-tapping bolts to secure the filler plate on the brake spider.



447-0059

Figure 5. Self-Tapping Screws.

4. Assemble the large C-section of the dust shield onto the brake spider and over the filler plate studs. Install the two self-tapping bolts to hold the C-section onto the brake spider.

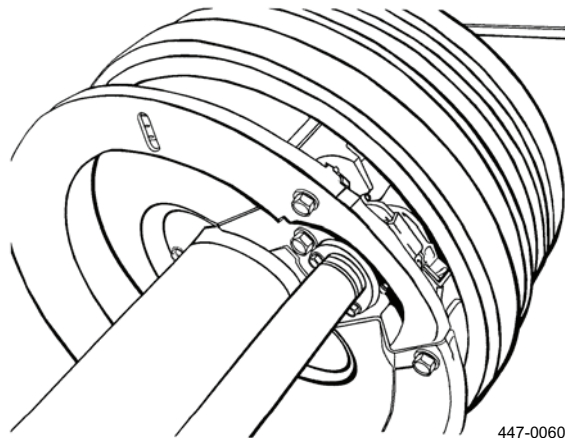

447-0060

Figure 6. C-Section of Dust Shield.

DUST SHIELD REMOVAL AND INSTALLATION - CONTINUED

5. Install the two nuts onto the filler plate studs to secure the filler plate to the C-section of the dust shield.
6. Reposition the brake drum tight against the hub flange and check for any dust shield interferences. If there are any light interference conditions, the dust shield can be slightly displaced by using a small pry bar between the drum and dust shield in the area where they are rubbing.

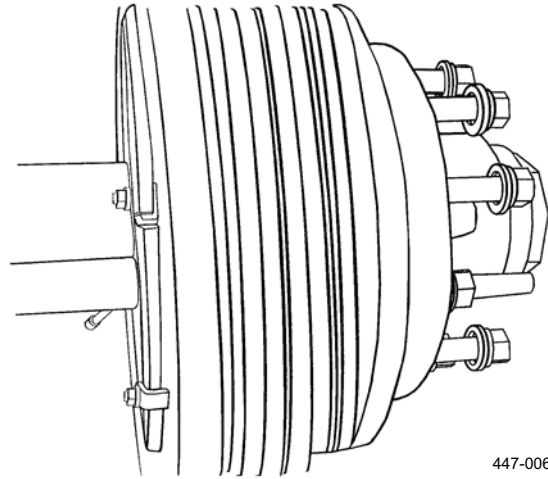
**Figure 7. Filler Plate.**

7. Ensure plugs (Figure 8, Item 12) are installed.

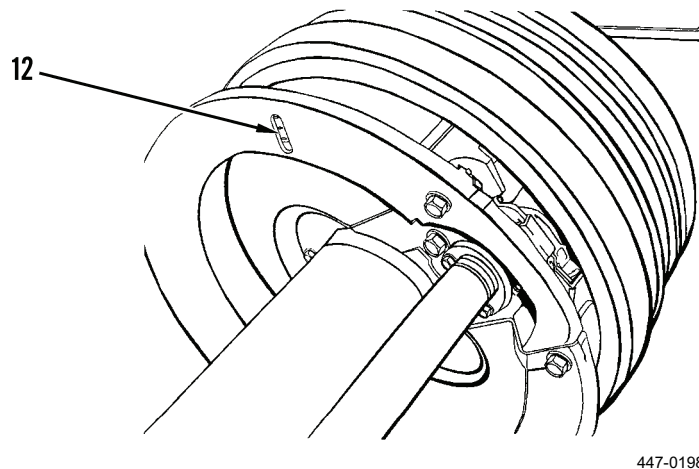
**Figure 8. Plugs.****END OF TASK**

FOLLOW-ON TASKS

1. Install brake drum (WP 0033).
2. Install tire and wheel (WP 0021).
3. Remove jack stands.
4. Connect semitrailer to prime mover.
5. Raise landing legs.
6. Remove/store chocks and ground boards.
7. Road test to check for proper/safe operation.

END OF TASK**END OF WORK PACKAGE**

ORGANIZATIONAL MAINTENANCE
HUBS AND DRUMS REPLACEMENT
Removal, Installation

INITIAL SETUP
Maintenance Level

Organizational

Tools and Special Tools

Tool kit, general mechanic's (Item 4, WP 0082)
 Shop equipment, automotive maintenance and repair (Item 3, WP 0082)
 Socket (Item 11, WP 0082)
 Torque wrench, 0 to 200 lb-in. (0 to 22.6 Nm) (Item 8, WP 0082)
 Floor jacks
 Jack stands

Materials/Parts

Oil, lubricating (Item 11, WP 0085)
 Gasket (4)
 Keeper arm

Materials/Parts - Continued

Lockwasher (24)
 Seal (4)

References

WP 0067
 WP 0097
 WP 0102
 WP 0105
 WP 0106
 WP 0108

Equipment Conditions

Landing legs down
 Semitrailer disconnected from prime mover
 Tires and wheels removed (WP 0021)
 Ground boards emplaced

WARNING

- Jack must be positioned directly under axle to prevent slippage. Direct all personnel to stay clear of semitrailer when semitrailer is supported in the air. Failure to comply may result in injury or death to personnel or damage to equipment.
- To prevent shifting of semitrailer, floor jack should be used only on a hard, level surface. Use ground boards, if necessary. Chock tires. Failure to comply may result in injury or death to personnel.

NOTE

- ABS tone ring is part of hub assembly not a separate item of supply.
- There are four sets of hub and drums on the semitrailer. This procedure removes and installs one complete set.
- Repair, turning, and final disposition of drums are Direct Support tasks.
- Brake drums may be re-bored at Direct Support. Reference WP 0106.
- See WP 0067, WP 0097, WP 0102, WP 0105, and WP 0108 for technical data on brakes.

REMOVAL

1. Remove brake drum (Figure 1, Item 14) and 10 wheel studs (Figure 1, Item 4) from hub (Figure 1, Item 3).
2. Remove six screws (Figure 1, Item 13), lockwashers (Figure 1, Item 12), hubcap (Figure 1, Item 11), and gasket (Figure 1, Item 10) from hub (Figure 1, Item 3). Discard lockwashers and gasket.
3. Remove keeper arm (Figure 1, Item 9) and self-locking nut (Figure 1, Item 8) from spindle (WP 0108). Discard keeper arm.
4. Remove outer cone and rollers (Figure 1, Item 1), inner tapered roller cup (Figure 1, Item 2), hub (Figure 1, Item 3), tapered cup (Figure 1, Item 5), cone and rollers (Figure 1, Item 6), and seal (Figure 1, Item 7). Discard seal.

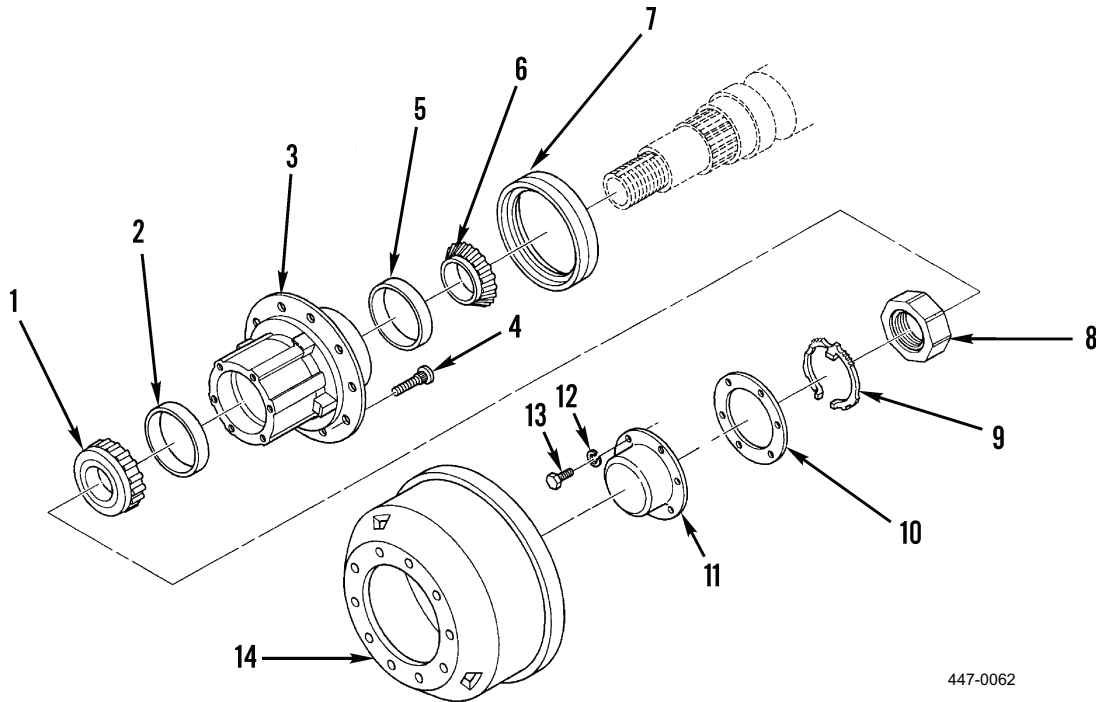

Figure 1. Hub and Drum.

END OF TASK**INSTALLATION****CAUTION**

Seal is tool-installed, pressed into hub, and must not be cocked or distorted. Spindle must be clean. Failure to comply could cause damage to equipment.

NOTE

Grease seal is installed in hub. Use of a seal installation tool is the best method for installation of seal.

1. Install new seal (Figure 1, Item 7), cone and rollers (Figure 1, Item 6), tapered cup (Figure 1, Item 5), hub (Figure 1, Item 3), tapered roller cup (Figure 1, Item 2), and cone and rollers (Figure 1, Item 1) onto spindle.
2. Install self-locking nut (Figure 1, Item 8) and new keeper arm (Figure 1, Item 9) onto spindle (WP 0108).

INSTALLATION - CONTINUED**NOTE**

Tighten hubcap fasteners to 15 lb-ft (20.3 Nm).

3. Install new gasket (Figure 1, Item 10) and hubcap (Figure 1, Item 11) onto hub (Figure 1, Item 3) using six new lockwashers (Figure 1, Item 12) and screws (Figure 1, Item 13). Gasket should be dry.

WARNING

Do not get oil on mounting face of drum or wheel. Failure to comply may result in injury or death to personnel.

NOTE

- All flange nuts and studs are right-hand threads.
 - Apply two drops of oil between nut and flange.
 - Apply two drops of oil to last two or three threads at end of each stud.
 - Using oil, lightly lubricate pilots on hub to ease wheel and removal and installation.
4. Seat brake drum (Figure 1, Item 14) onto hub (Figure 1, Item 3) using 10 wheel studs (Figure 1, Item 4) as guides. Do not damage threads.

END OF TASK**FOLLOW-ON TASKS**

1. Install tires and wheels (WP 0021).
2. Connect semitrailer to prime mover.
3. Raise landing legs.
4. Remove/store chocks and ground boards.
5. Road test to check for safe operation.

END OF TASK**END OF WORK PACKAGE**

ORGANIZATIONAL MAINTENANCE
AUTOMATIC SLACK ADJUSTERS MAINTENANCE
Removal, Installation, Adjustment

INITIAL SETUP**Maintenance Level**

Organizational

Tools and Special ToolsTool kit, general mechanic's (Item 4, WP 0082)
Jack stands**Equipment Conditions**Landing legs down
Semitrailer disconnected from prime mover
Tires chocked
Ground boards emplaced**References**

WP 0110

WARNING

Do not use any great with Teflon, over 3% molysulfide content, or "white" great in the automatic slack adjusters. These lubricants will adversely affect the friction clutch and cause it not to hold the adjustment, resulting in premature failure, injury to personnel, and damage to equipment.

CAUTION

- Electrical or pneumatic tools shall not be used for slack adjustment.
- Initial adjustments procedure starts with measurement not tear-down.
- Failure to comply could cause damage to equipment.

NOTE

There are four slack adjusters and they are removed and installed the same way. This procedure covers one slack adjuster.

REMOVAL

1. See WP 0110 for technical data on automatic slack adjuster.
2. Remove nut (Figure 1, Item 4), bracket (Figure 1, Item 5), stud (Figure 1, Item 3), and bushing (Figure 1, Item 2) from slack adjuster (Figure 1, Item 1).

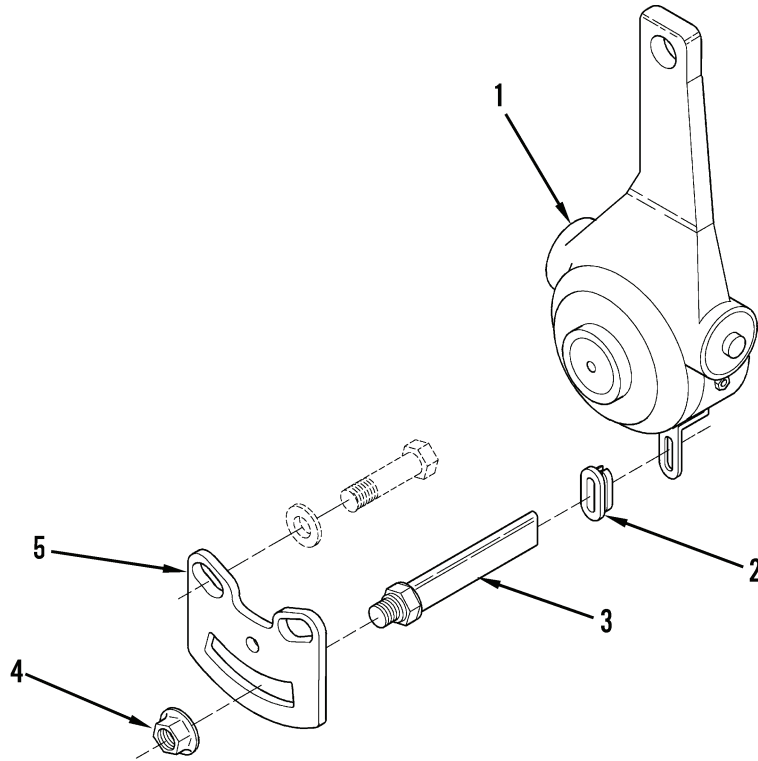

447-0063

Figure 1. Automatic Slack Adjuster.**END OF TASK****INSTALLATION**

1. Install bushing (Figure 1, Item 2), stud (Figure 1, Item 3), bracket (Figure 1, Item 5), and nut (Figure 1, Item 4) on slack adjuster (Figure 1, Item 1).
2. See WP 0110 for technical data on automatic slack adjustment.

END OF TASK**ADJUSTMENT**

See WP 0110.

END OF TASK

FOLLOW-ON TASKS

1. Remove wheel chocks.
2. Connect semitrailer to prime mover.
3. Raise landing legs.
4. Remove/store chocks and ground boards.
5. Road test to ensure proper operation.

END OF TASK**END OF WORK PACKAGE**

ORGANIZATIONAL MAINTENANCE
ECU VALVE REPLACEMENT**Removal, Installation**

INITIAL SETUP
Maintenance Level

Organizational

References

WP 0105

Tools and Special Tools

Tool kit, general mechanic's (Item 4, WP 0082)

Jack stands

Equipment Conditions

Landing legs down

Electrical power disconnected

Semitrailer disconnected from prime mover

Tires chocked on both sides of vehicle

Ground boards emplaced

Air reservoirs drained (WP 0018)

Materials/Parts

Sealing compound (Item 15, WP 0085)

WARNING

Wear protective goggles when underneath semitrailer. Failure to comply could result in injury to personnel.

CAUTION

Do not use Teflon tape. Doing so could cause damage to equipment.

NOTE

See WP 0105 for technical data on air brake system.

REMOVAL

1. Disconnect four sensor cables from ECU valve (Figure 1, Item 2).
2. Disconnect electrical cables from ECU valve (Figure 1, Item 2).
3. Remove two hoses and two elbows from curbside of ECU valve (Figure 1, Item 2).
4. Remove two pipe plugs (Figure 1, Item 3) from rear of ECU valve (Figure 1, Item 2).
5. Remove two elbow fittings and two hoses from roadside of ECU valve (Figure 1, Item 2).
6. Remove pipe nipple (Figure 1, Item 1) from front air reservoir and pull away ECU valve (Figure 1, Item 2) from front air reservoir.

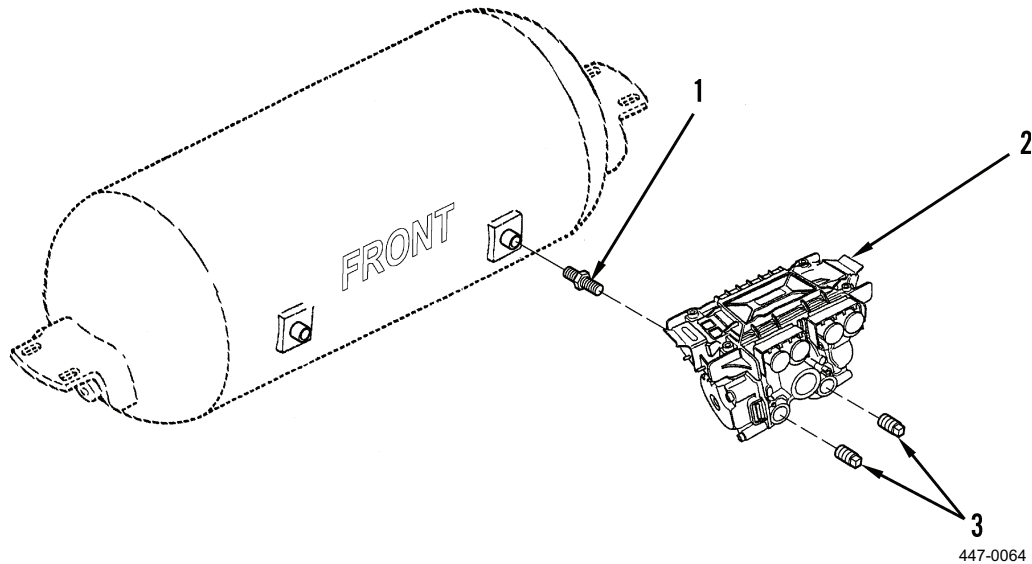

Figure 1. ECU Valve.

END OF TASK**INSTALLATION**

1. Apply sealing compound to threads of elbows, pipe plugs (Figure 1, Item 3), and nipple (Figure 1, Item 1). Do not use Teflon tape.
2. Install two elbow fittings, hoses, pipe plugs (Figure 1, Item 3), and pipe nipple (Figure 1, Item 1) on ECU valve (Figure 1, Item 2).
3. Install ECU valve (Figure 1, Item 2) and nipple (Figure 1, Item 1) on front air reservoir.
4. Install two elbows and hoses on curbside of ECU valve (Figure 1, Item 2).
5. Connect all electrical cables to ECU valve (Figure 1, Item 2).
6. Connect four sensor cables to ECU valve (Figure 1, Item 2).

END OF TASK

FOLLOW-ON TASKS

1. Connect semitrailer to prime mover.
2. Raise landing legs.
3. Remove/store chocks and ground boards.
4. Road test to check for air leaks and warning light operation.

END OF TASK**END OF WORK PACKAGE**

ORGANIZATIONAL MAINTENANCE**ABS BRAKE POWER CONNECTIONS REPLACEMENT****Removal, Installation**

INITIAL SETUP**Maintenance Level**

Organizational

References

WP 0105

Tools and Special Tools

Tool kit, general mechanic's (Item 4, WP 0082)

Equipment Conditions

Landing legs down

Semitrailer disconnected from prime mover

Electrical power disconnected

Tires chocked

Ground boards emplaced

Air reservoirs drained (WP 0018)

Materials/Parts

Tiedown strap (Item 17, WP 0085)

Locknut (4)

WARNING

Wear protective goggles when underneath semitrailer. Failure to comply could result in injury to personnel.

NOTE

See WP 0105 for technical data on air brake system.

REMOVAL

1. Remove four sensor clips (Figure 1, Item 10) from four sensors on inside hub of four inner wheels.
2. Remove four sensors (Figure 1, Item 9) from inside hub of four inner wheels. Hand-install sensors or lightly push into clip using a wooden dowel rod.
3. Disconnect four sensor cables (Figure 1, Item 8) from four sensors (Figure 1, Item 9).
4. Disconnect four sensor cables (Figure 1, Item 8) from ECU valve.
5. Disconnect diagnostic tool (Figure 1, Item 1) from power/diagnostic cable (Figure 1, Item 7).
6. Disconnect power/diagnostic cable (Figure 1, Item 7) from ECU valve, power supply, and mounting bracket (Figure 1, Item 3), removing four screws (Figure 1, Item 4), eight washers (Figure 1, Item 5), and four locknuts (Figure 1, Item 6). Discard locknuts.

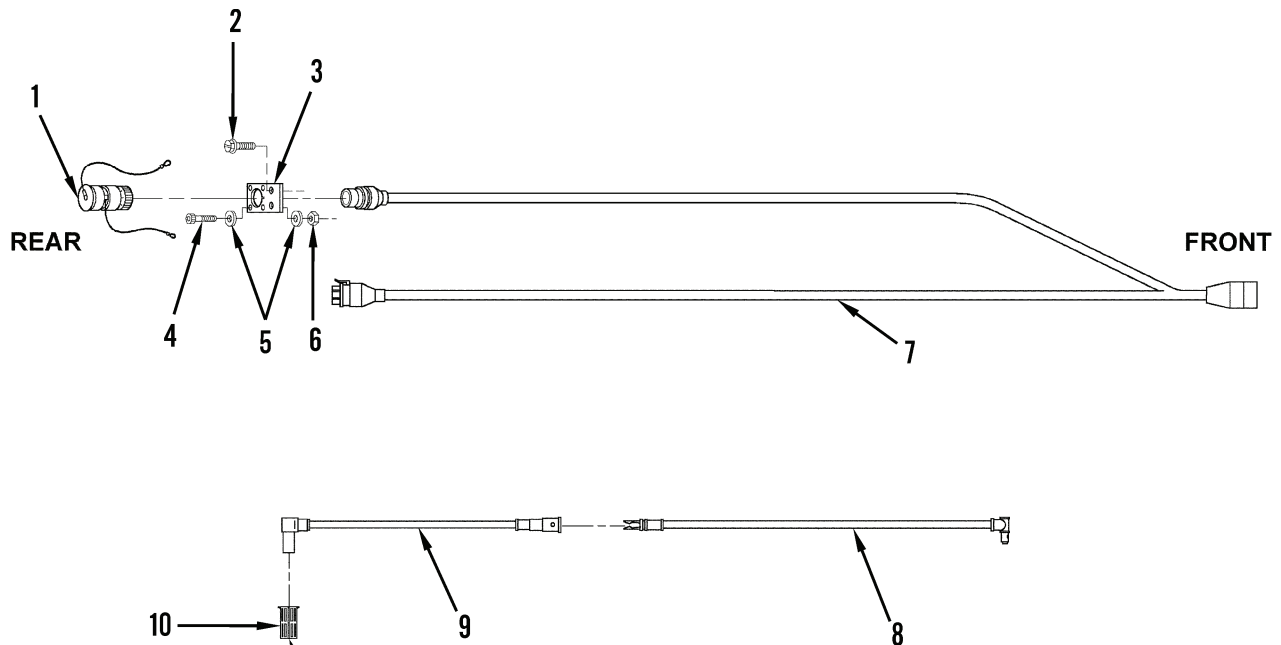

447-0065

Figure 1. ABS Brake Power Connections.**END OF TASK****INSTALLATION**

1. Connect diagnostic/power cable (Figure 1, Item 7) to ECU valve, power supply, and mounting bracket (Figure 1, Item 3) with four screws (Figure 1, Item 4), eight washers (Figure 1, Item 5), and four new locknuts (Figure 1, Item 6).
2. Connect diagnostic tool (Figure 1, Item 1) to diagnostic/power cable (Figure 1, Item 7).
3. Connect four sensor cables (Figure 1, Item 8) to ECU valve.
4. Connect four sensor cables (Figure 1, Item 8) to four sensors (Figure 1, Item 9).
5. Install four sensors (Figure 1, Item 9) on inside hubs of the four inner wheels.
6. Secure four sensors (Figure 1, Item 9) to wheel hubs with sensor clips (Figure 1, Item 10).

INSTALLATION - CONTINUED**CAUTION**

Sensor cables must be strapped at the 12 o'clock or 3 o'clock position on the axle (top or rearward side of axle) to protect them during off-road operation. Use as many tiedown straps as required to ensure the cables are tightly secured to the axle ends. Failure to do so could result in damage to equipment.

NOTE

Attach nylon tiedown straps to axle allowing for easy replacement. Locking tab shall be situated within 90 degrees of axle top.

7. Secure sensor cables (Figure 2, Item 8) to axle with nylon tiedown straps (Figure 2, Item 11).

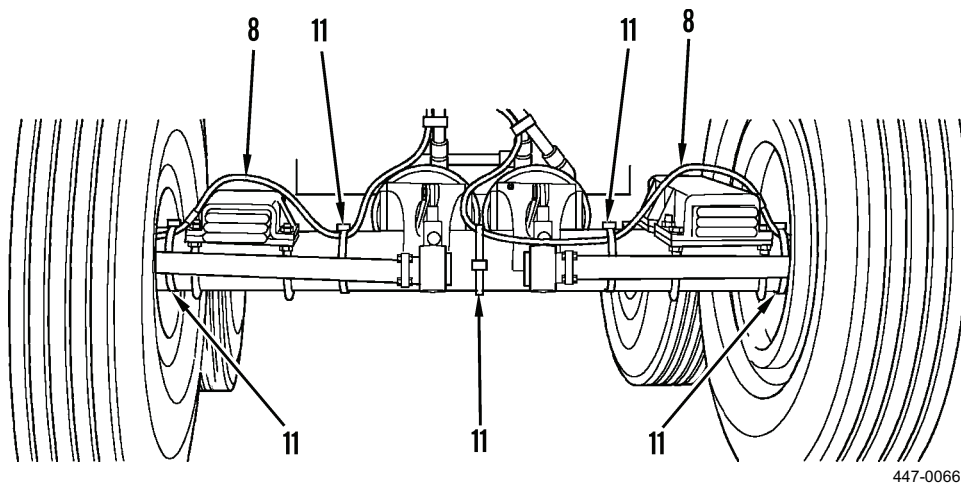

Figure 2. Sensor Cables.

END OF TASK**FOLLOW-ON TASKS**

1. Connect semitrailer to prime mover.
2. Raise landing legs.
3. Remove/store chocks and ground boards.
4. Road test to check for ABS warning light operation.

END OF TASK**END OF WORK PACKAGE**

ORGANIZATIONAL MAINTENANCE
AIR LINES AND FITTINGS REPLACEMENT
Removal, Installation

INITIAL SETUP**Maintenance Level**

Organizational

Tools and Special Tools

Tool kit, general mechanic's (Item 4, WP 0082)

Jack stands

References

WP 0035

WP 0040

References - Continued

WP 0096

WP 0105

Equipment Conditions

Landing legs down

Semitrailer disconnected from prime mover

Tires chocked

Ground boards emplaced

Air reservoirs drained (WP 0018)

WARNING

- Wear protective goggles when underneath trailer. Failure to comply could result in injury to personnel.
- Pressurized air (100 psi/690 kPa) may cause injury to personnel or damage to equipment.
- Do not overtighten hose end brass fittings. The fittings should be installed finger tight with an additional 1 to 1-1/2 turns using a wrench. Do not twist hoses. Check for air leaks. Failure to follow this warning may cause the fittings to fail, brake lock-up, and possible injury or death to personnel.

NOTE

See WP 0096 and WP 0105 for technical data on air brake system.

REMOVAL

1. Remove hose clips (Figure 1, Item 13) and hose clamps (Figure 1, Item 14) as necessary.
2. Remove two adapters (Figure 1, Item 17) from two gladhands and remove two hoses (Figure 1, Item 16), adapters (Figure 1, Item 15), tube adapters (Figure 1, Item 1), and tubes (Figure 1, Items 2 and 8).
3. Remove adapter (Figure 1, Item 1) from air reservoir.
4. Remove pipe tee (Figure 1, Item 12) from ECU valve, elbow (Figure 1, Item 3) from front air reservoir, and remove adapter (Figure 1, Item 15).
5. Remove two elbows (Figure 1, Item 3) from front and rear air reservoirs and remove tube (Figure 1, Item 2).
6. Remove adapter (Figure 1, Item 1) from front air reservoir.
7. Remove tube (Figure 1, Item 8) from elbow (Figure 1, Item 3), pipe coupling (Figure 1, Item 5), and hose assembly (Figure 1, Item 6).
8. Remove elbow (Figure 1, Item 3), hose (Figure 1, Item 8), adapter (Figure 1, Item 1), and pipe tee (Figure 1, Item 9) from air brake chambers.
9. Remove two elbows (Figure 1, Item 7), hose assemblies (Figure 1, Item 6), pipe couplings (Figure 1, Item 5), and elbows (Figure 1, Item 4).
10. Remove two elbows (Figure 1, Item 3) from ECU valve and two tubes (Figure 1, Item 2).
11. Remove elbow (Figure 1, Item 3), tube (Figure 1, Item 8), adapter (Figure 1, Item 1), and pipe tee (Figure 1, Item 9) from air brake chamber.
12. Remove three elbows (Figure 1, Item 7), hose assemblies (Figure 1, Item 6), and pipe bushings (Figure 1, Item 10).
13. Remove two elbows (Figure 1, Item 7) from ECU valve.
14. Remove elbow (Figure 1, Item 7).
15. Remove two pipe plugs (Figure 1, Item 11) from control valve (WP 0040).
16. Remove two pipe plugs (Figure 1, Item 11) from ECU valve (WP 0035).

REMOVAL - CONTINUED

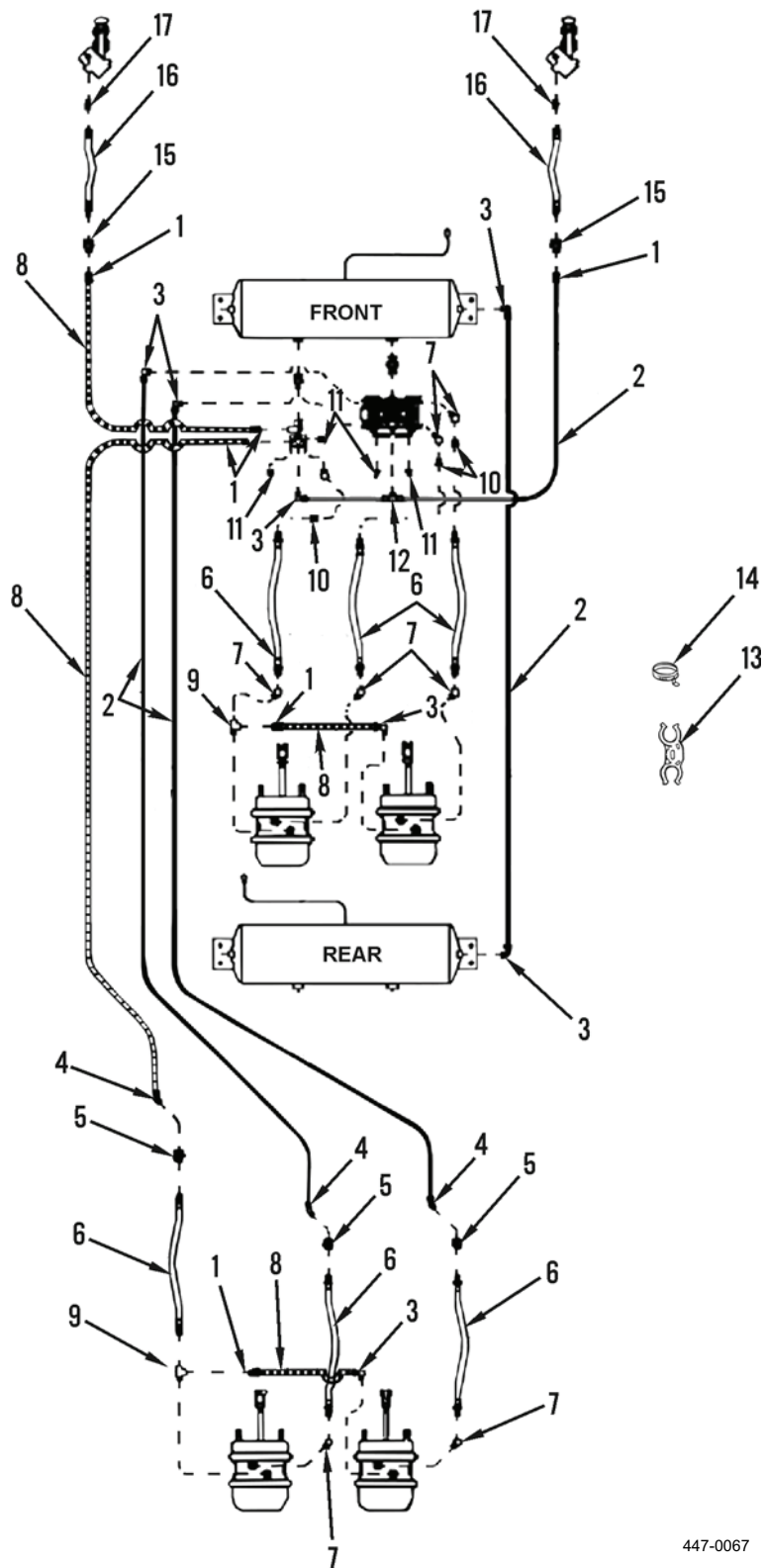

447-0067

Figure 1. Air Lines and Fittings.

END OF TASK

INSTALLATION

1. Install two pipe plugs (Figure 2, Item 11) in ECU valve (WP 0035).
2. Install two pipe plugs (Figure 2, Item 11) in control valve (WP 0040).
3. Install elbow (Figure 2, Item 7).
4. Install two elbows (Figure 2, Item 7) in ECU valve.
5. Install three pipe bushings (Figure 2, Item 7), hose assemblies (Figure 2, Item 1), and elbows (Figure 2, Item 2).
6. Install pipe tee (Figure 2, Item 9), adapter (Figure 2, Item 1), tube (Figure 2, Item 8), and elbow (Figure 2, Item 3) in air brake chamber. Do not twist hoses.
7. Install two elbows (Figure 2, Item 3) onto ECU valve and two tubes (Figure 2, Item 2).
8. Install two elbows (Figure 2, Item 4), pipe couplings (Figure 2, Item 5), hose assemblies (Figure 2, Item 6), and elbows (Figure 2, Item 7) in two tubes (Figure 2, Item 8).
9. Install pipe tee (Figure 2, Item 9), adapter (Figure 2, Item 1), hose (Figure 2, Item 8), and elbow (Figure 2, Item 3) on air brake chambers.
10. Install hose assembly (Figure 2, Item 6), pipe coupling (Figure 2, Item 5), and elbow (Figure 2, Item 4) on tube (Figure 2, Item 8).
11. Install adapter (Figure 2, Item 1) on front air reservoir.
12. Install two elbows (Figure 2, Item 3) on front and rear air reservoirs and install tube (Figure 2, Item 2).
13. Install pipe tee (Figure 2, Item 1) on ECU valve and elbow (Figure 2, Item 3) on front air reservoir and install tube (Figure 2, Item 15).
14. Install adapter (Figure 2, Item 22) on air reservoir.
15. Install two adapters (Figure 2, Item 1) on two gladhands and install tubes (Figure 2, Items 2 and 8).
16. Install hose clamps (Figure 2, Item 14) and hose clips (Figure 2, Item 13) as necessary.

INSTALLATION - CONTINUED

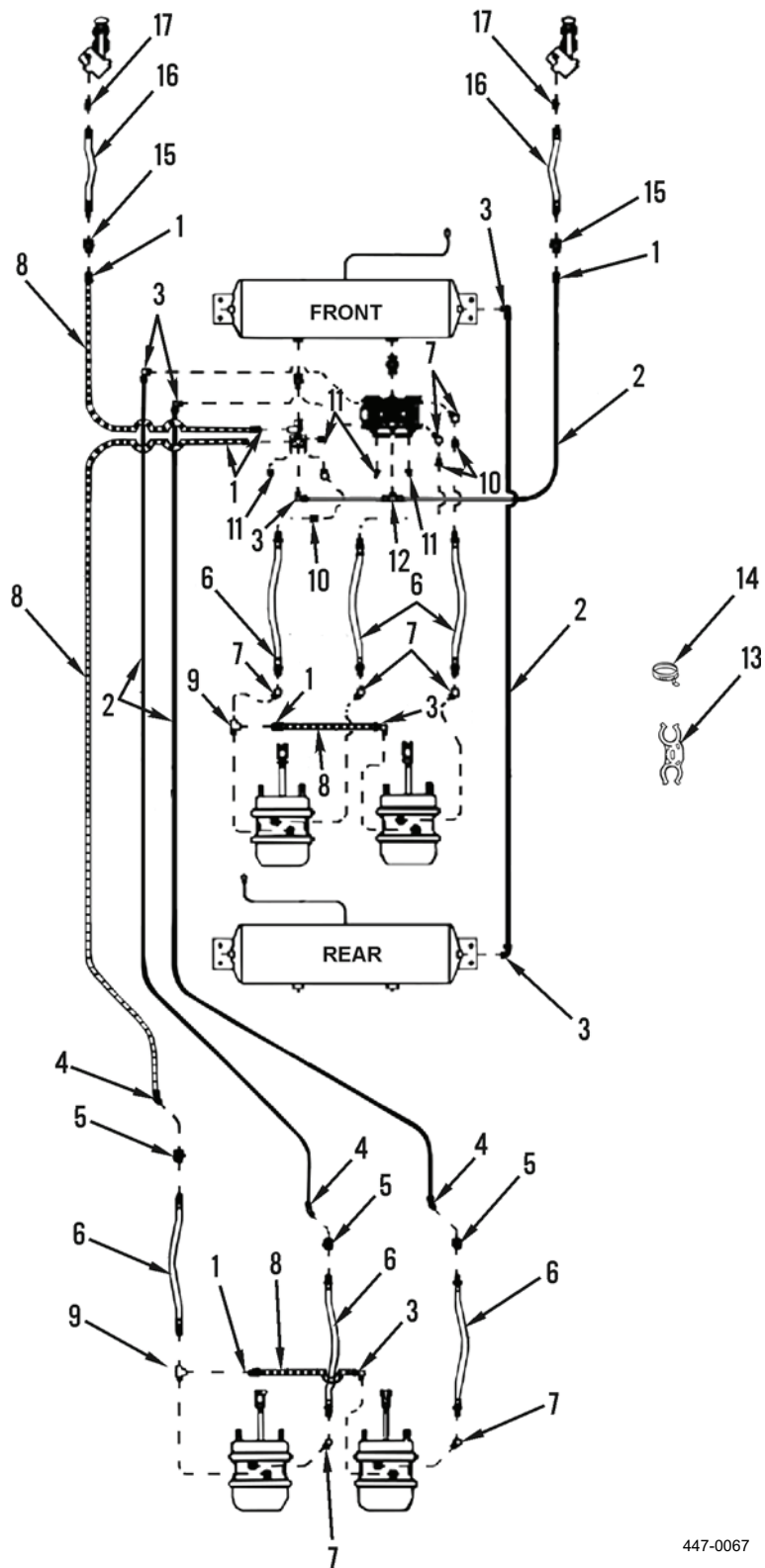

447-0067

Figure 2. Air Lines and Fittings.

END OF TASK

FOLLOW-ON TASKS

1. Connect semitrailer to prime mover.
2. Raise landing legs.
3. Remove/store chocks and ground boards.
4. Pressurize system and check for leaks.
5. Road test system to ensure proper operation.

END OF TASK**END OF WORK PACKAGE**

ORGANIZATIONAL MAINTENANCE
AIR BRAKE CHAMBERS REPLACEMENT
Removal, Installation

INITIAL SETUP**Maintenance Level**

Organizational

Tools and Special Tools

Tool kit, general mechanic's (Item 4, WP 0082)

Jack stands

Materials/Parts

Cotter pin (4)

Locknut (8)

References

WP 0096

WP 0106

WP 0110

Equipment Conditions

Landing legs down

Semitrailer disconnected from prime mover

Tires chocked

Ground boards emplaced

Air reservoirs drained (WP 0018)

WARNING

- Disassembly of air brake chambers is NOT authorized. When inspecting or caging air brake chambers, do not position yourself in front of, or in line with, the chamber. Failure to follow this warning may result in injury or death to personnel.
- Discarded air brake chambers must be safely and properly disposed of. They should be disarmed prior to disposal. Failure to disarm assembly prior to disposal may, in time, result in spontaneous release of the spring chamber and its contents, causing death, personal injury, and/or property damage.
- Before performing any work on the spring brake system, chock the wheels front and rear to prevent semitrailer movement. Failure to follow this warning may result in injury or death to personnel.
- Wear protective goggles when underneath trailer. Failure to comply may result in injury to personnel.
- All brake chambers must be caged before working on the brake system to prevent serious injury to personnel and damage to equipment.

NOTE

- See WP 0096 for technical data on air brake system. See WP 0110 for technical data on automatic slack adjusters.
- There are four air brake chambers and they are removed and installed the same way. This procedure covers one air brake chamber.

REMOVAL

1. Loosen jamnut (Figure 1, Item 5). Remove cotter pin, pin, and yoke assembly (Figure 1, Item 4), and jamnut. Discard cotter pin.
2. Remove two locknuts (Figure 1, Item 3), washers (Figure 1, Item 2), and air brake chamber (Figure 1, Item 1). Discard locknuts.

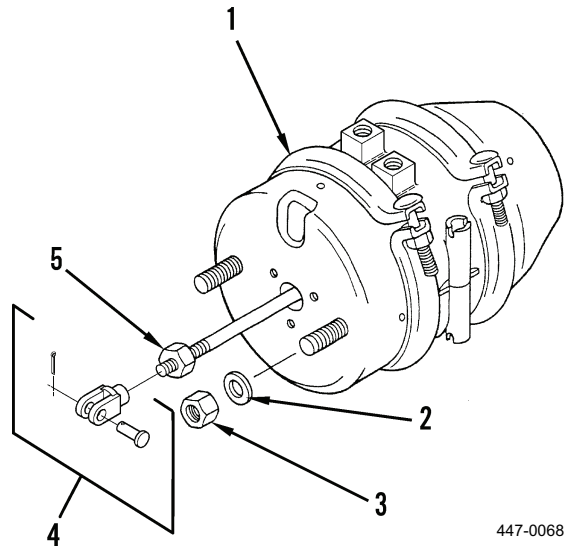

Figure 1. Air Brake Chamber.

END OF TASK**INSTALLATION**

1. Install air brake chamber (Figure 1, Item 1), two washers (Figure 1, Item 2), and new locknuts (Figure 1, Item 3).
2. Install jamnut (Figure 1, Item 5), yoke assembly, pin, and new cotter pin (Figure 1, Item 4). Tighten jamnut.

END OF TASK**FOLLOW-ON TASKS**

1. Connect semitrailer to prime mover.
2. Remove tire chocks.
3. Raise landing legs.
4. Remove/store ground boards.
5. Pressurize system.
6. Check system for air leaks.
7. Road test to check for safe operation.

END OF TASK**END OF WORK PACKAGE**

ORGANIZATIONAL MAINTENANCE**AIR RESERVOIRS REPLACEMENT****Removal, Installation**

INITIAL SETUP**Maintenance Level**

Organizational

Tools and Special Tools

Tool kit, general mechanic's (Item 4, WP 0082)

Jack stands

Materials/Parts

Locknut (8)

Equipment Conditions

Landing legs down

Semitrailer disconnected from prime mover

Tires chocked

Ground boards emplaced

Air reservoirs drained (WP 0018)

ECU valve removed (WP 0035)

WARNING

Wear protective goggles when underneath semitrailer. Failure to comply could result in injury to personnel.

REMOVAL

1. Remove four locknuts (Figure 1, Item 2), washers (Figure 1, Item 4), hex screws (Figure 1, Item 5), two rubber pads (Figure 1, Item 3), and front air reservoir (Figure 1, Item 1) from mounts. Discard locknuts.
2. Remove drain valve (Figure 1, Item 7) and pipe plug (Figure 1, Item 8) from front air reservoir (Figure 1, Item 1).
3. Remove four locknuts (Figure 1, Item 2), washers (Figure 1, Item 4), hex screws (Figure 1, Item 5), two rubber pads (Figure 1, Item 3), and rear air reservoir (Figure 1, Item 6) from mounts. Discard locknuts.
4. Remove two pipe plugs (Figure 1, Item 9), drain valve (Figure 1, Item 7), and pipe plug (Figure 1, Item 8) from rear air reservoir (Figure 1, Item 6).

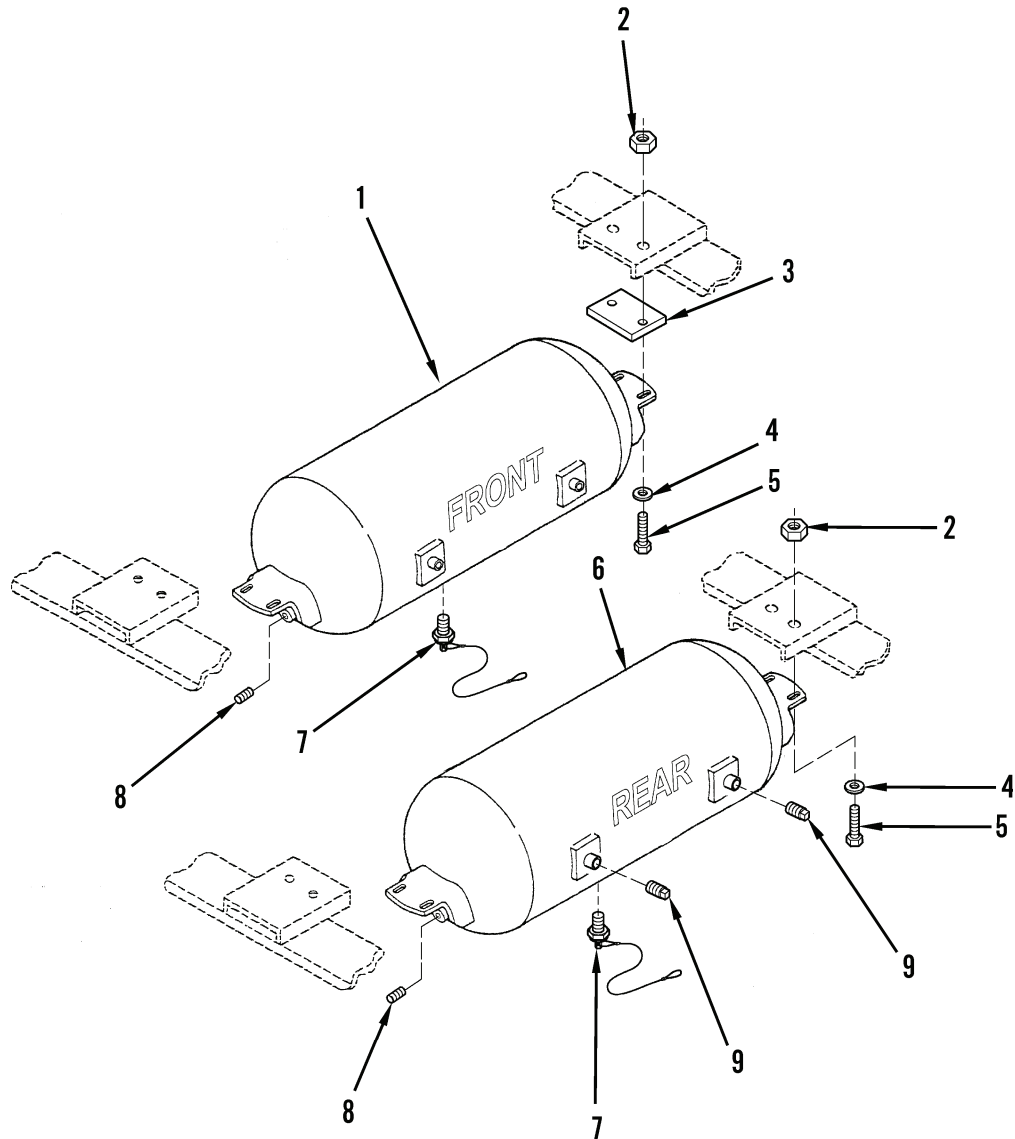

447-0069

Figure 1. Air Reservoirs.**END OF TASK**

INSTALLATION

1. Install two pipe plugs (Figure 1, Item 9), drain valve (Figure 1, Item 7), and pipe plug (Figure 1, Item 8) on rear air reservoir (Figure 1, Item 6).
2. Install rear air reservoir (Figure 1, Item 6) on mounts using four hex screws (Figure 1, Item 5), washers (Figure 1, Item 4), two rubber pads (Figure 1, Item 3), and four new locknuts (Figure 1, Item 2).
3. Install drain valve (Figure 1, Item 7) and pipe plug (Figure 1, Item 8) on front air reservoir (Figure 1, Item 1).
4. Install front air reservoir (Figure 1, Item 1) on mounts using four hex screws (Figure 1, Item 5), washers (Figure 1, Item 4), two rubber pads (Figure 1, Item 3), and four new locknuts (Figure 1, Item 2).

END OF TASK**FOLLOW-ON TASKS**

1. Install ECU control valve on rear tank (WP 0035).
2. Connect semitrailer to prime mover.
3. Remove tire chocks.
4. Raise landing legs.
5. Remove/store ground boards.
6. Pressurize system.
7. Check for air leaks.
8. Road test to ensure safe operation.

END OF TASK**END OF WORK PACKAGE**

ORGANIZATIONAL MAINTENANCE**AIR BRAKE CHAMBER CONTROL VALVE REPLACEMENT**
Removal, Installation

INITIAL SETUP**Maintenance Level**

Organizational

Tools and Special Tools

Tool kit, general mechanic's (Item 4, WP 0082)

References

WP 0037

Equipment Conditions

Landing legs down

Semitrailer disconnected from prime mover

Tires chocked

Ground boards emplaced

Air reservoirs drained (WP 0018)

WARNING

Wear protective goggles when underneath trailer. Failure to comply could result in injury to personnel.

NOTE

- Retain plugs and save after removal.
- The air lines connected to the air brake chamber control valve must be removed prior to this procedure. See WP 0037 for technical data on air lines and fittings.

REMOVAL

1. Remove air brake chamber control valve (Figure 1, Item 3) with nipple (Figure 1, Item 1) attached from front air reservoir.
2. Remove nipple (Figure 1, Item 1) and two pipe plugs (Figure 1, Item 2) from air brake chamber control valve (Figure 1, Item 3).

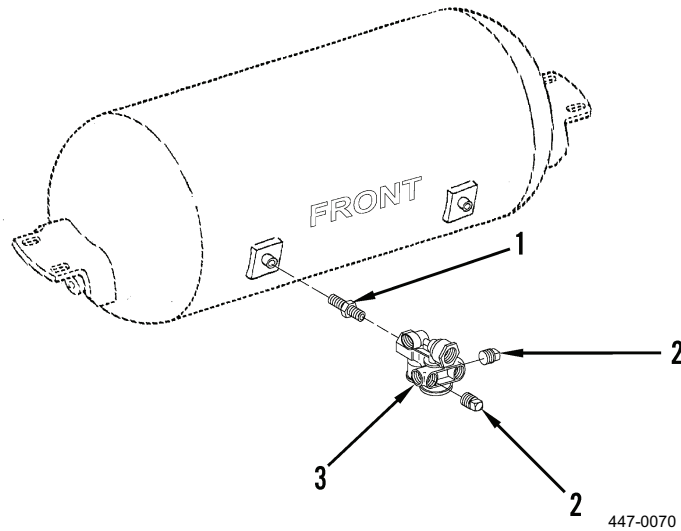

Figure 1. Air Brake Chamber Control Valve.

END OF TASK**INSTALLATION**

1. Install nipple (Figure 1, Item 1) in air brake chamber control valve (Figure 1, Item 3) at RES port. Install two pipe plugs (Figure 1, Item 2).
2. Install air brake chamber control valve (Figure 1, Item 3) with nipple (Figure 1, Item 1) in front air reservoir.

END OF TASK**FOLLOW-ON TASKS**

1. Couple semitrailer to prime mover.
2. Remove tire chocks from both sides and store.
3. Raise landing legs.
4. Remove/store ground boards.
5. Check for air leakage.
6. Road test to check for proper/safe operation.

END OF TASK**END OF WORK PACKAGE**

ORGANIZATIONAL MAINTENANCE
GLADHANDS REPLACEMENT (M871R)
Removal, Installation

INITIAL SETUP**Maintenance Level**

Organizational

Tools and Special Tools

Tool kit, general mechanic's (Item 4, WP 0082)

Materials/Parts

Screw, self-tapping (6)

Equipment Conditions

Landing legs down

Semitrailer disconnected from prime mover

Tires chocked

Ground boards emplaced

NOTE

- Gladhands are removed and installed in the same way. This procedure is for one gladhand.
- Packing for service gladhand is blue and packing for emergency gladhand is red.
- Hose for service gladhand is blue and hose for emergency gladhand is red.

REMOVAL

1. Remove two self-tapping screws (Figure 1, Item 1) and cover plate (Figure 1, Item 2). Discard self-tapping screws.

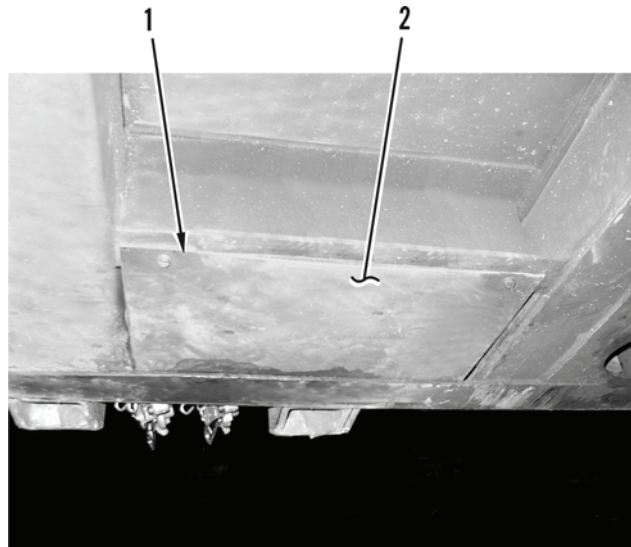

447-0205

Figure 1. Cover Plate.

REMOVAL - CONTINUED

2. Disconnect hose (Figure 2, Item 3) from gladhand (Figure 2, Item 7).
3. Remove three self-tapping screws (Figure 2, Item 5), washer (Figure 2, Item 6), and gladhand (Figure 2, Item 7). Discard self-tapping screw.
4. Remove packing (Figure 2, Item 4) from gladhand (Figure 2, Item 7).

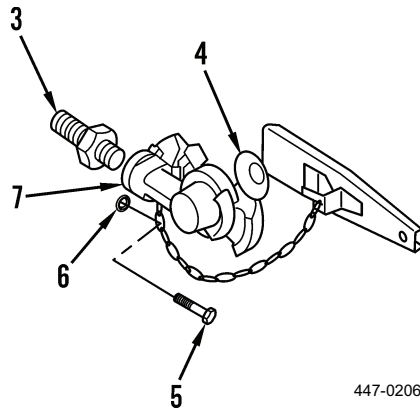
**Figure 2. Gladhand.****END OF TASK****INSTALLATION**

1. Install packing (Figure 2, Item 4) in gladhand (Figure 2, Item 7).
2. Install gladhand (Figure 2, Item 7), washer (Figure 2, Item 6), and three new self-tapping screws (Figure 2, Item 5).
3. Connect hose (Figure 2, Item 3) to gladhand (Figure 2, Item 7).
4. Install cover plate (Figure 3, Item 2) and two new self-tapping screws (Figure 3, Item 1).

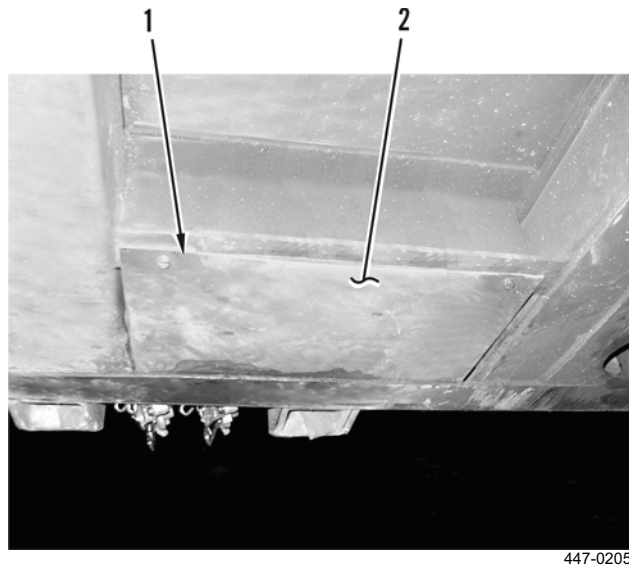
**Figure 3. Cover Plate.****END OF TASK**

FOLLOW-ON TASKS

1. Connect semitrailer to prime mover.
2. Raise landing legs.
3. Remove/store chocks and ground boards.
4. Check for air leaks.

END OF TASK**END OF WORK PACKAGE**

ORGANIZATIONAL MAINTENANCE
GLADHANDS REPLACEMENT (M871A1R AND M871A2R)
Removal, Installation

INITIAL SETUP
Maintenance Level

Organizational

Equipment Conditions

Landing legs down

Semitrailer disconnected from prime mover

Tools and Special Tools

Tool kit, general mechanic's (Item 4, WP 0082)

Tires chocked

Ground boards emplaced

Materials/Parts

Oil, lubricating (Item 11, WP 0085)

Screw, self-tapping (7)

NOTE

- Gladhands are removed and installed in the same way, except service gladhand has three self-tapping screws and emergency gladhand has four self-tapping screws. This procedure is for the service gladhand.
- Packing for service gladhand is blue and packing for emergency gladhand is red.
- Hose for service gladhand is blue and hose for emergency gladhand is red.

REMOVAL

1. Remove packing (Figure 1, Item 3) from gladhand (Figure 1, Item 4).
2. Remove three self-tapping screws (Figure 1, Item 2) and pull out gladhand (Figure 1, Item 4). Discard self-tapping screws.
3. Disconnect hose (Figure 1, Item 1) and remove gladhand (Figure 1, Item 4).

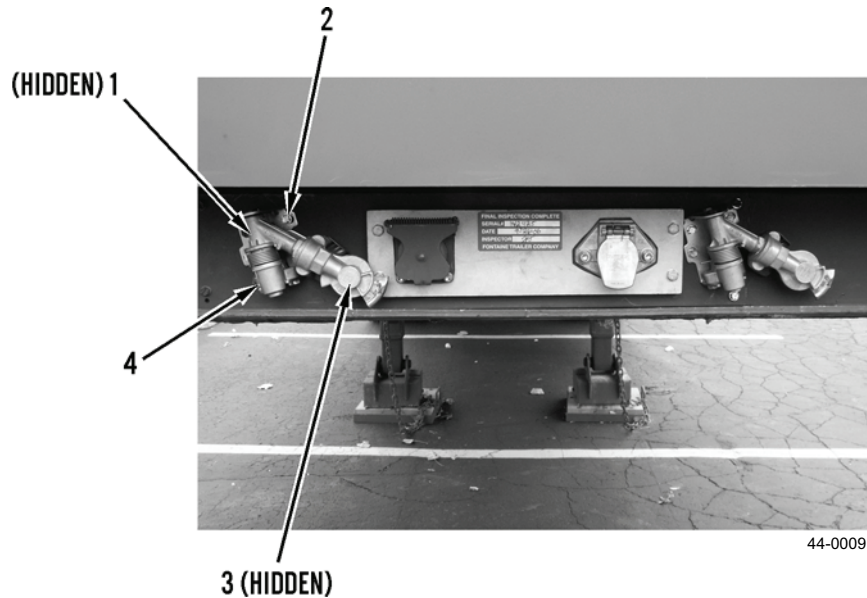

Figure 1. Gladhands.

END OF TASK**INSTALLATION**

1. Connect hose (Figure 1, Item 1) to gladhand (Figure 1, Item 4).
2. Install gladhand (Figure 1, Item 4) and three new self-tapping screws (Figure 1, Item 2).
3. Install packing (Figure 1, Item 3) on gladhand (Figure 1, Item 4).

END OF TASK**FOLLOW-ON TASKS**

1. Lubricate swing arm with 10-wt. oil.
2. Connect semitrailer to prime mover.
3. Raise landing legs.
4. Remove/store chocks and ground boards.
5. Check for air leaks.

END OF TASK**END OF WORK PACKAGE**

ORGANIZATIONAL MAINTENANCE
DOCK BUMPERS REPLACEMENT (M871R AND M871A1R)
Removal, Installation

INITIAL SETUP**Maintenance Level**

Organizational

Tools and Special Tools

Tool kit, general mechanic's (Item 4, WP 0082)

Materials/Parts

Nut, self-locking (8)

Equipment Conditions

Landing legs down

Semitrailer disconnected from prime mover

Tires chocked

Ground boards emplaced

WARNING

Chock tires to prevent semitrailer movement. Failure to do so could result in injury to personnel.

NOTE

- There are four dock bumpers and they are removed and installed the same way. The following procedure covers one dock bumper.
- The M871R uses self-locking nuts; the M871A1R uses nuts.

REMOVAL

Remove two self-locking nuts (Figure 1, Item 1), bolts (Figure 1, Item 4), four washers (Figure 1, Item 2), and bumper (Figure 1, Item 3). Discard self-locking nuts.

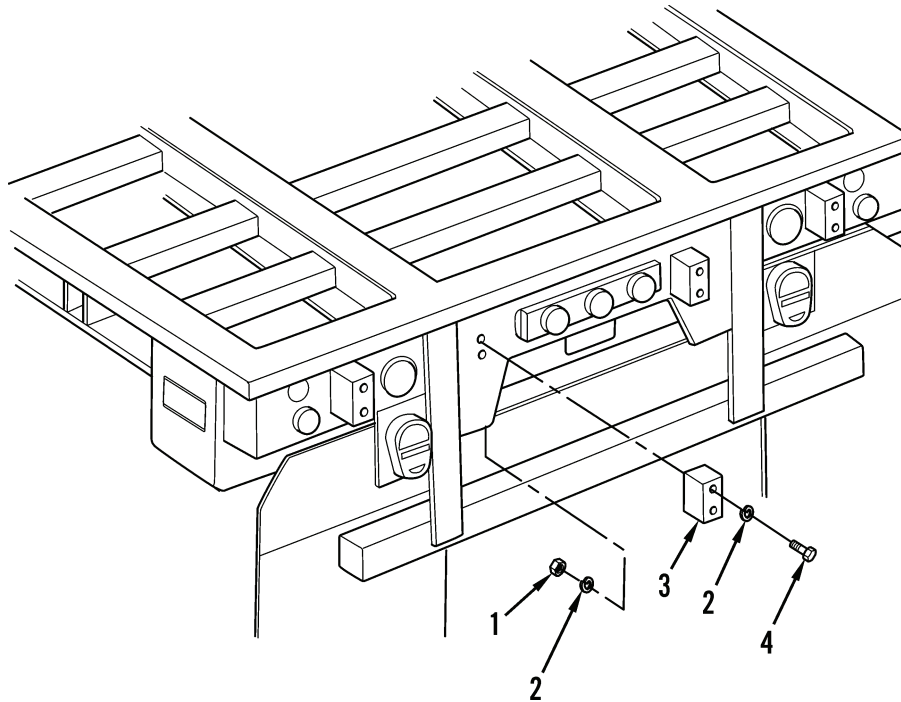

447-0200

Figure 1. Dock Bumper.

END OF TASK**INSTALLATION**

Install bumper (Figure 1, Item 3), four washers (Figure 1, Item 2), two bolts (Figure 1, Item 4), and new self-locking nuts (Figure 1, Item 1).

END OF TASK**FOLLOW-ON TASKS**

1. Connect semitrailer to prime mover.
2. Raise landing legs.
3. Remove/store chocks and ground boards.

END OF TASK**END OF WORK PACKAGE**

ORGANIZATIONAL MAINTENANCE
DOCK BUMPERS REPLACEMENT (M871A2R)
Removal, Installation

INITIAL SETUP
Maintenance Level

Organizational

Tools and Special Tools

Tool kit, general mechanic's (Item 4, WP 0082)

Materials/Parts

Locknut (8)

Equipment Conditions

Landing legs down

Semitrailer disconnected from prime mover

Tires chocked

Ground boards emplaced

WARNING

Chock tires to prevent semitrailer movement. Failure to do so could result in injury to personnel.

NOTE

There are two dock bumpers and they are removed and installed the same way. This procedure covers one dock bumper.

REMOVAL

Remove four locknuts (Figure 1, Item 1), bolts (Figure 1, Item 4), washers (Figure 1, Item 3), and bumper (Figure 1, Item 2). Discard locknuts.

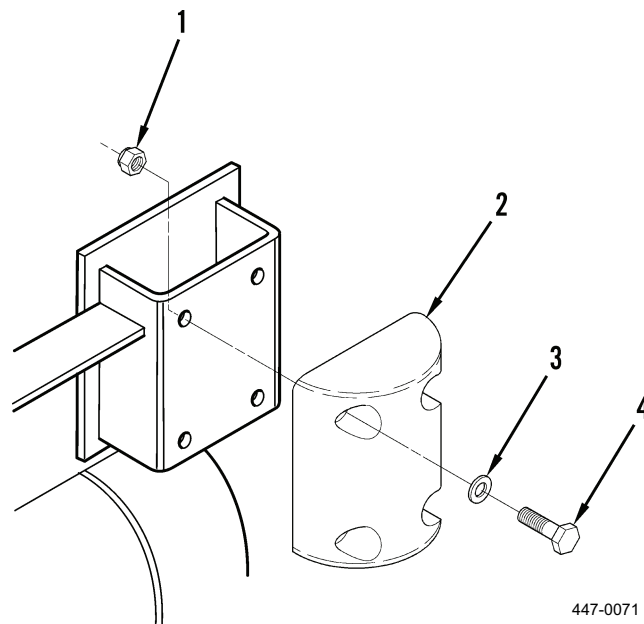

Figure 1. Dock Bumper.

END OF TASK

INSTALLATION

Install bumper (Figure 2, Item 2), four washers (Figure 2, Item 3), bolts (Figure 2, Item 4), and new locknuts (Figure 2, Item 1).

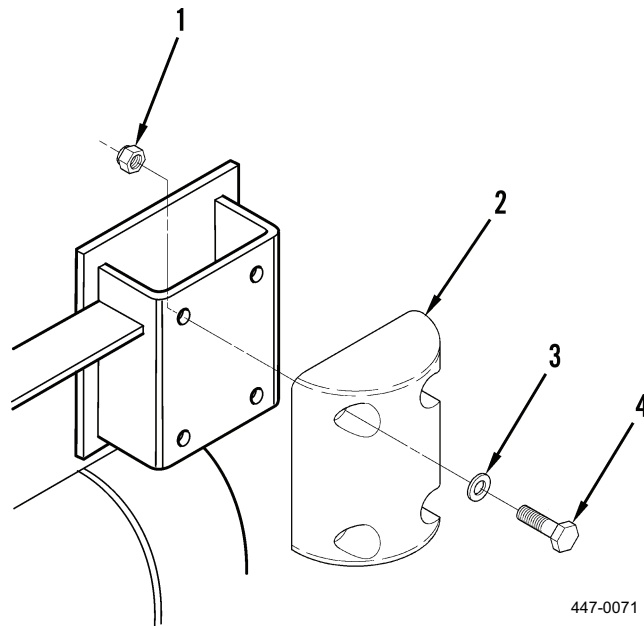

Figure 2. Dock Bumper.

END OF TASK**FOLLOW-ON TASKS**

1. Connect semitrailer to prime mover.
2. Raise landing legs.
3. Remove/store chocks and ground boards.

END OF TASK**END OF WORK PACKAGE**

ORGANIZATIONAL MAINTENANCE
RETRACTABLE TWIST LOCKS MAINTENANCE (M871R AND M871A1R)
**Removal, Disassembly, Repair,
Assembly, Installation**

INITIAL SETUP
Maintenance Level

Organizational

References

WP 0023

Tools and Special Tools

Tool kit, general mechanic's (Item 4, WP 0082)

Equipment Conditions

Landing legs down

Semitrailer disconnected from prime mover

Tires chocked

Ground boards emplaced

Materials/Parts

Oil, lubricating (Item 11, WP 0085)

Pin (8)

NOTE

- Ensure retractable twist lock pocket is clean and free of debris.
- Socket cup is welded in. This task is accomplished at Direct Support maintenance.
- There are four retractable twist locks and they are removed and installed the same way. This procedure covers one retractable twist lock.
- See WP 0023 for additional service requirements.

REMOVAL

1. Lower twist lock.
2. Drive out pin (Figure 1, Item 1) and remove lower assembly (Figure 1, Item 2) by turning clockwise. Discard pin.
3. Remove upper assembly (Figure 1, Item 3), taking care not to separate locator block and bayonet.

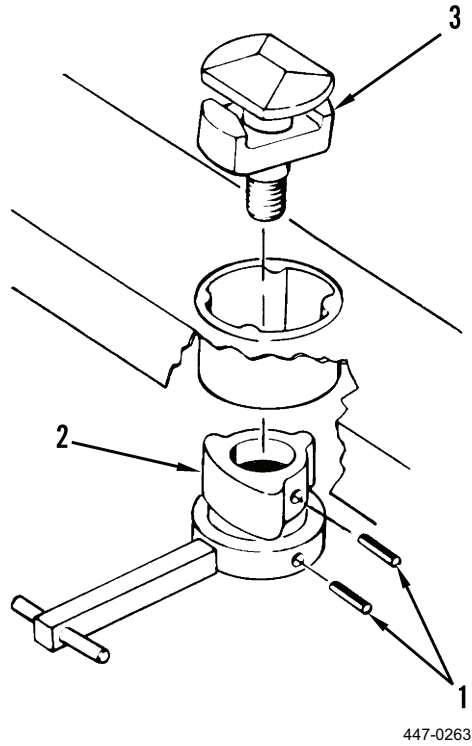

Figure 1. Retractable Twist Lock.

END OF TASK

DISASSEMBLY**CAUTION**

Take care in separating locator block and bayonet to prevent loss of springs and balls.

1. Remove setscrew (Figure 2, Item 1), spring (Figure 2, Item 2), and ball (Figure 2, Item 3).
2. Separate locator block (Figure 2, Item 4) and bayonet (Figure 2, Item 5).
3. Remove ball (Figure 2, Item 6) and spring (Figure 2, Item 7).

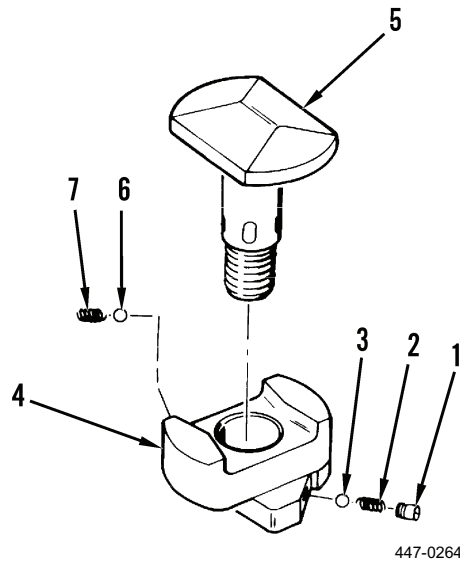

Figure 2. Upper Assembly.

4. Remove and discard pin (Figure 3, Item 1).
5. Remove handle (Figure 3, Item 2) from base cap (Figure 3, Item 3).

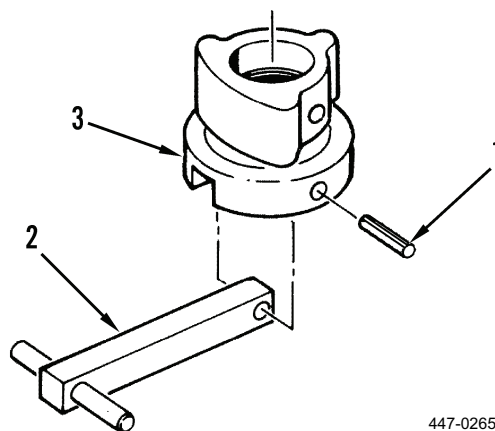

Figure 3. Lower Assembly.

END OF TASK

REPAIR

Repair is by replacement of assembly only.

END OF TASK**ASSEMBLY**

1. Install handle (Figure 4, Item 2) to base cap (Figure 4, Item 3).
2. Install new pin (Figure 4, Item 1).

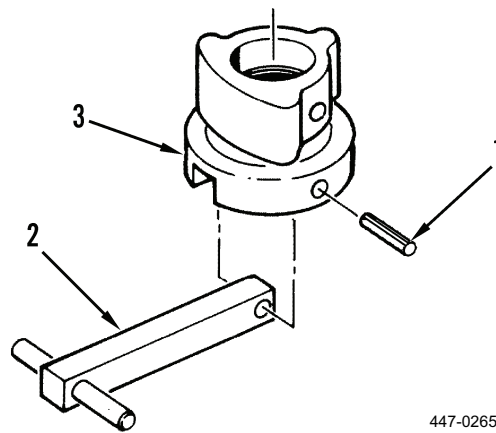

Figure 4. Lower Assembly.

3. Place spring (Figure 5, Item 7) and ball (Figure 5, Item 6) into position.
4. Install locator block (Figure 5, Item 4) to bayonet (Figure 5, Item 5).
5. Install ball (Figure 5, Item 3), spring (Figure 5, Item 2), and setscrew (Figure 5, Item 1).

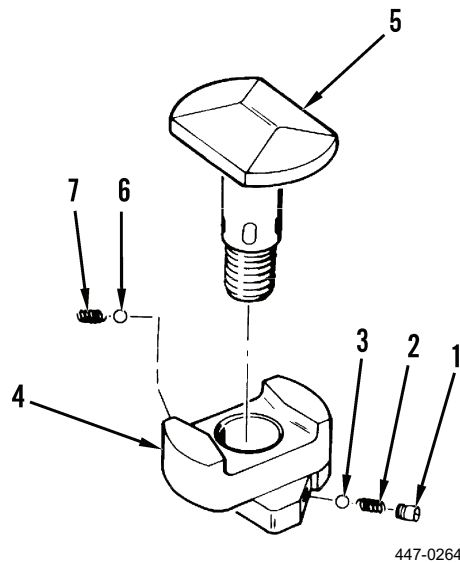

Figure 5. Upper Assembly.

END OF TASK

INSTALLATION

1. Install upper assembly (Figure 6, Item 3).
2. Install lower assembly (Figure 6, Item 2). Turn clockwise and align holes for pin (Figure 6, Item 1).
3. Install new pin (Figure 6, Item 1).

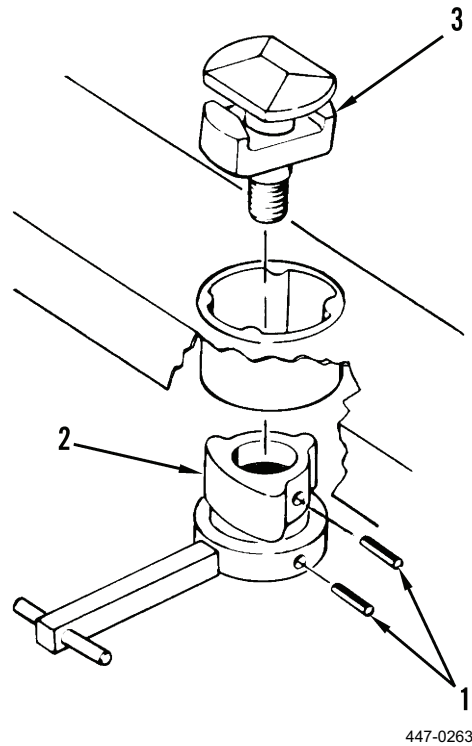

Figure 6. Retractable Twist Lock.

END OF TASK**FOLLOW-ON TASKS**

1. Lubricate twist lock with 10-wt. oil.
2. Make sure twist lock operates freely with no binding.
3. Connect semitrailer to prime mover.
4. Raise landing legs.
5. Remove/store chocks and ground boards.

END OF TASK**END OF WORK PACKAGE**

ORGANIZATIONAL MAINTENANCE**RETRACTABLE TWIST LOCKS REPLACEMENT (M871A2R)****Removal, Installation**

INITIAL SETUP**Maintenance Level**

Organizational

References

WP 0023

Tools and Special Tools

Tool kit, general mechanic's (Item 4, WP 0082)

Equipment Conditions

Landing legs down

Semitrailer disconnected from prime mover

Tires chocked

Ground boards emplaced

Materials/Parts

Oil, lubricating (Item 11, WP 0085)

Pin (8)

NOTE

- Ensure retractable twist lock pocket is clean and free of debris.
- Item 8 (socket) is welded in. This task is accomplished at Direct Support maintenance.
- There are four retractable twist locks and they are removed and installed the same way. This procedure covers one retractable twist lock.
- See WP 0023 for additional service requirements.

REMOVAL

1. Remove elastic strap (Figure 1, Item 4) from eye bolt (Figure 1, Item 5). Lower handle (Figure 1, Item 1) to vertical position.
2. Remove elastic strap (Figure 1, Item 4) from handle (Figure 1, Item 1).
3. Lower twist lock (Figure 1, Item 2) in socket (Figure 1, Item 8) to access pin (Figure 1, Item 3).
4. Drive pin (Figure 1, Item 3) from twist lock (Figure 1, Item 2) and remove twist lock from socket (Figure 1, Item 8). Discard pin.
5. Remove nut (Figure 1, Item 7), eye bolt (Figure 1, Item 5), and nut (Figure 1, Item 6).

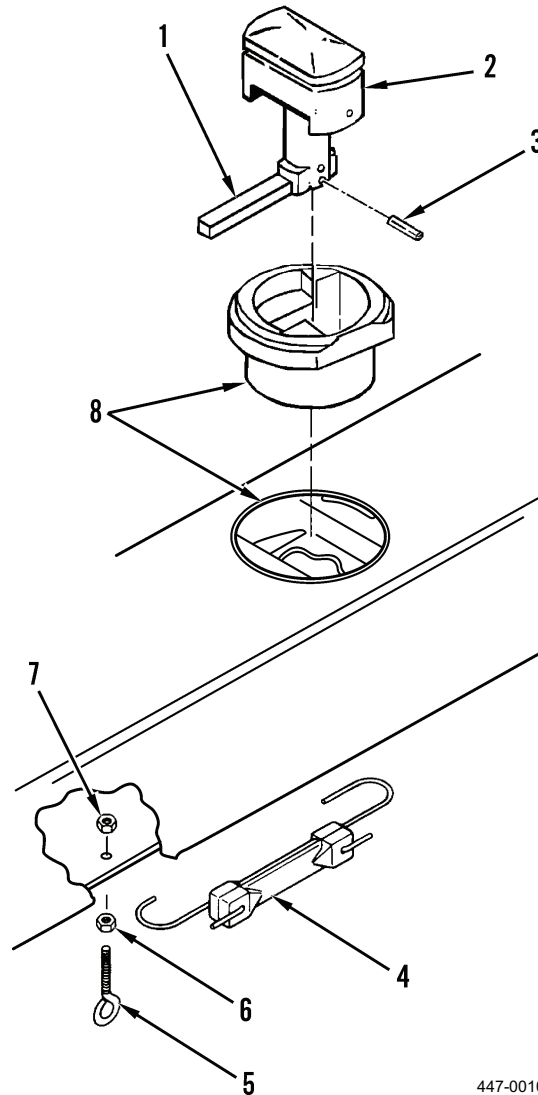

447-0010

Figure 1. Retractable Twist Lock.**END OF TASK**

INSTALLATION

1. Install nut (Figure 1, Item 6), eye bolt (Figure 1, Item 5), and nut (Figure 1, Item 7).
2. Install twist lock (Figure 1, Item 2) in socket (Figure 1, Item 8) and drive new pin (Figure 1, Item 3) into twist lock.
3. Install elastic strap (Figure 1, Item 4) on handle (Figure 1, Item 1).
4. Lift end of handle (Figure 1, Item 1) and secure elastic strap (Figure 1, Item 4) to eye bolt (Figure 1, Item 5).

END OF TASK**FOLLOW-ON TASKS**

1. Lubricate twist lock with 10-wt. oil.
2. Make sure twist lock operates freely with no binding.
3. Connect semitrailer to prime mover.
4. Raise landing legs.
5. Remove/store chocks and ground boards.

END OF TASK**END OF WORK PACKAGE**

ORGANIZATIONAL MAINTENANCE**TIEDOWN RINGS MAINTENANCE****Removal, Modification,
Installation**

INITIAL SETUP**Maintenance Level**

Organizational

Tools and Special Tools

Tool kit, general mechanic's (Item 4, WP 0082)

Materials/Parts

Locknut (20)

Equipment Conditions

Landing legs down

Semitrailer disconnected from prime mover

Tires chocked

Ground boards emplaced

REMOVAL**NOTE**

There are 10 tiedown rings and they are removed and installed the same way. This procedure covers one tiedown ring.

Remove two locknuts (Figure 1, Item 5), screws (Figure 1, Item 1), strap (Figure 1, Item 3), and tiedown ring (Figure 1, Item 2) from frame (Figure 1, Item 4). Discard locknuts.

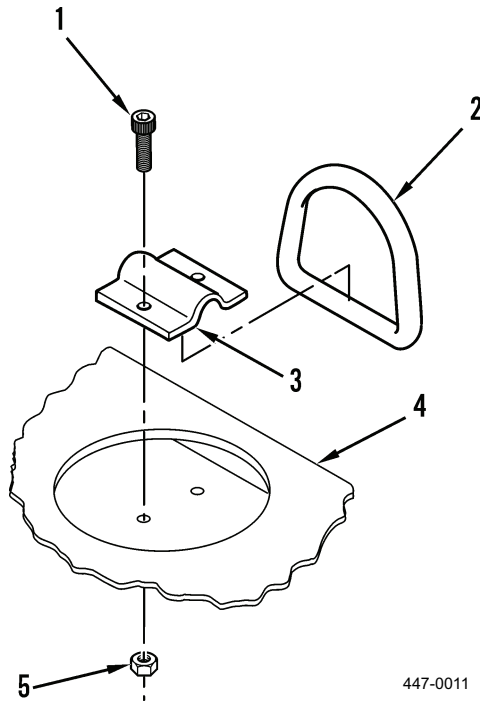

447-0011

Figure 1. Tiedown Rings.**END OF TASK**

MODIFICATION**NOTE**

There are different configurations of the tiedown rings. Check that the strap bolt holes align with the holes in the recessed mounting plate. If the holes do not align, a hole will have to be drilled as shown in *Modification* in this work package. If the holes align, proceed to *Installation* in this work package.

1. Align new hole center to the centerline of the existing holes (Figure 2, Item A).
2. Locate new hole center 1-1/2 in. (38 mm) on the recessed mounting plate toward the outside of the side rail (Figure 2, Item B).

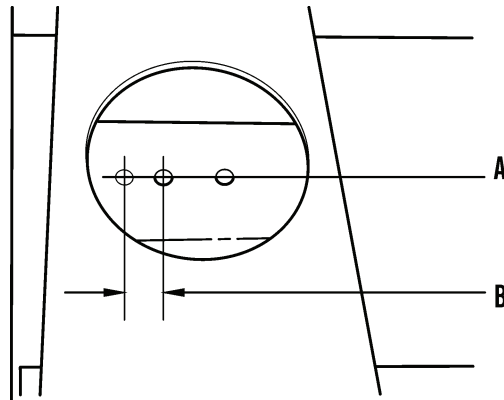

447-0207

Figure 2. Location of Hole to be Drilled.

3. Drill 7/16 in. (11 mm) hole (Figure 3, Item C) in the recessed mounting plate.

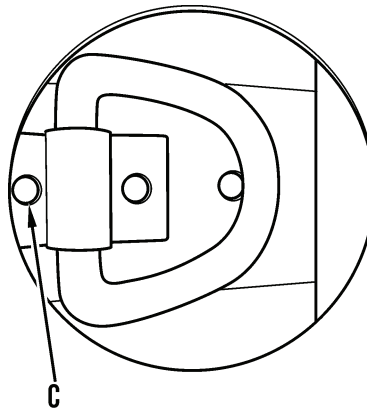

447-0208

Figure 3. Drilling New Hole.**END OF TASK**

INSTALLATION**NOTE**

The OEM hole (Figure 4, Item D) in the recessed mounting plate toward the inside of the side rail is not used.

Install tiedown ring (Figure 4, Item 2), strap (Figure 4, Item 3), two screws (Figure 4, Item 1), and new locknuts (Figure 4, Item 5). Tighten locknuts to 20 to 28 lb-ft (27 to 38 Nm).

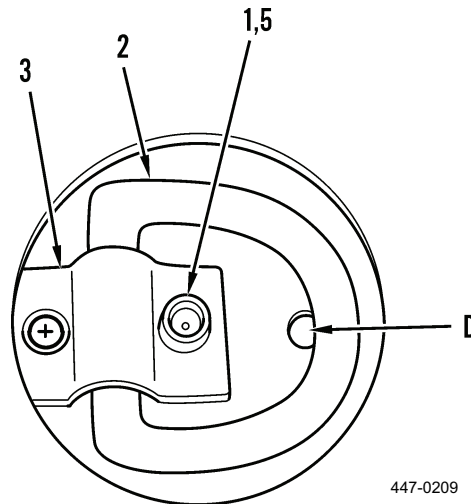

Figure 4. Tiedown Rings.

END OF TASK**FOLLOW-ON TASKS**

1. Connect semitrailer to prime mover.
2. Raise landing legs.
3. Remove/store chocks and ground boards.

END OF TASK**END OF WORK PACKAGE**

ORGANIZATIONAL MAINTENANCE
SPARE TIRE CARRIER MAINTENANCE
Removal, Disassembly, Repair,
Assembly, Installation

INITIAL SETUP**Maintenance Level**

Organizational

Tools and Special Tools

Tool kit, general mechanic's (Item 4, WP 0082)

Materials/Parts

Lockwasher (6)

Nut, self-locking (3)

Equipment Conditions

Landing legs down

Semitrailer disconnected from prime mover

Tires chocked

Ground boards emplaced

Spare tire removed (WP 0022)

NOTE

Some semitrailers have welded-on spare tire carriers. If spare tire carrier is welded to semitrailer, notify Direct Support Maintenance to replace welded-on spare tire carrier with bolt-on spare tire carrier.

REMOVAL

1. Support spare tire carrier (Figure 1, Item 12).
2. At inside bracket (Figure 1, Item 3), remove two nuts (Figure 1, Item 1), lockwashers (Figure 1, Item 2), screws (Figure 1, Item 5), and washers (Figure 1, Item 4). Discard lockwashers.
3. At two outside brackets (Figure 1, Item 9), remove four nuts (Figure 1, Item 10), lockwashers (Figure 1, Item 11), screws (Figure 1, Item 8), washers (Figure 1, Item 7), and spare tire carrier (Figure 1, Item 12). Discard lockwashers.

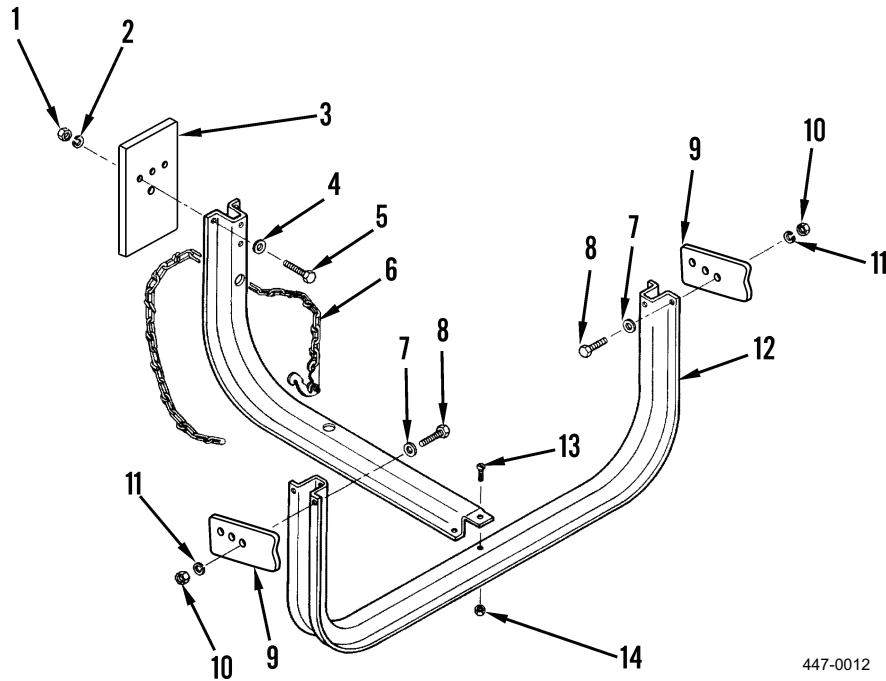

447-0012

Figure 1. Spare Tire Carrier.**END OF TASK****DISASSEMBLY**

1. Remove chain (Figure 1, Item 6) from spare tire carrier (Figure 1, Item 12).
2. Remove three self-locking nuts (Figure 1, Item 14) and screws (Figure 1, Item 13) and separate sections of spare tire carrier (Figure 1, Item 12). Discard self-locking nuts.

END OF TASK**REPAIR**

Repair is limited to replacement of chain (Figure 1, Item 6).

END OF TASK

ASSEMBLY

1. Connect sections of spare tire carrier (Figure 1, Item 12) and install three screws (Figure 1, Item 13) and new self-locking nuts (Figure 1, Item 14).
2. Install chain (Figure 1, Item 6) in spare tire carrier (Figure 1, Item 12).

END OF TASK**INSTALLATION**

1. Position and support spare tire carrier (Figure 1, Item 12).
2. At two outside brackets (Figure 1, Item 9), install four washers (Figure 1, Item 7), screws (Figure 1, Item 8), new lockwashers (Figure 1, Item 11), and nuts (Figure 1, Item 10).
3. At inside bracket (Figure 1, Item 3), install two washers (Figure 1, Item 4), screws (Figure 1, Item 5), new lockwashers (Figure 1, Item 2), and nuts (Figure 1, Item 1).

END OF TASK**FOLLOW-ON TASKS**

1. Install spare tire (WP 0022).
2. Connect semitrailer to prime mover.
3. Raise landing legs.
4. Remove/store chocks and ground boards.

END OF TASK**END OF WORK PACKAGE**

ORGANIZATIONAL MAINTENANCE
WHEEL CHOCKS REPAIR
Disassembly, Assembly

INITIAL SETUP
Maintenance Level

Organizational

Equipment Conditions

Landing legs down
 Semitrailer disconnected from prime mover
 Tires chocked
 Ground boards emplaced

Tools and Special Tools

Tool kit, general mechanic's (Item 4, WP 0082)

DISASSEMBLY
NOTE

There are four wheel chocks and they are stowed in the stowage box located on the left (road) side of the semitrailer.

Remove two clips (Figure 1, Item 1) and chain (Figure 1, Item 2) from two wheel chocks (Figure 1, Item 3).

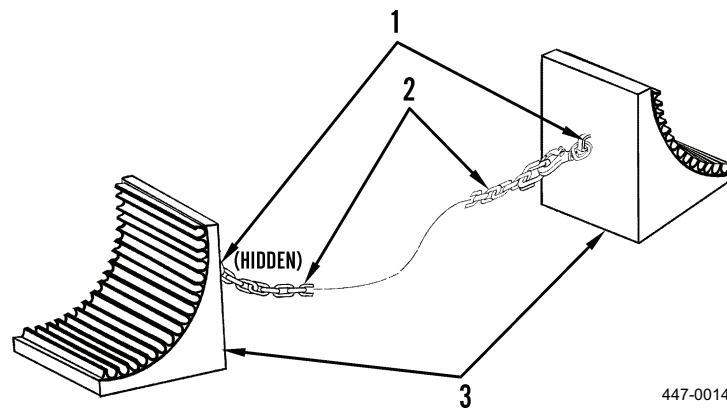

Figure 1. Wheel Chocks.

END OF TASK
ASSEMBLY

Install two clips (Figure 1, Item 1) and chain (Figure 1, Item 2) on two wheel chocks (Figure 1, Item 3).

END OF TASK

FOLLOW-ON TASKS

1. Connect semitrailer to prime mover.
2. Raise landing legs.
3. Remove/store ground boards.

END OF TASK**END OF WORK PACKAGE**

ORGANIZATIONAL MAINTENANCE**LANDING GEAR REPLACEMENT****Removal, Installation**

INITIAL SETUP**Maintenance Level**

Organizational

Personnel Required

Four

Tools and Special Tools

Tool kit, general mechanic's (Item 4, WP 0082)

Jack stands

References

WP 0094

Materials/Parts

Oil, lubricating (Item 11, WP 0085)

Nut, self-locking (8)

Locknut (22)

Rivet, pop (4)

Equipment Conditions

Semitrailer disconnected from prime mover

Semitrailer blocked on jack stands

Tires chocked

Ground boards emplaced

WARNING

Landing gear weighs 200 lb (91 kg). Use four personnel to replace landing gear. Failure to comply may result in injury or death to personnel.

NOTE

See WP 0094 for technical data.

REMOVAL

NOTE

Step 1 applies only to the M871R and M871A1R semitrailers.

1. Remove four self-locking nuts (Figure 1, Item 5), eight washers (Figure 1, Item 3), four screws (Figure 1, Item 4), and two brackets (Figure 1, Item 2). Discard self-locking nuts.

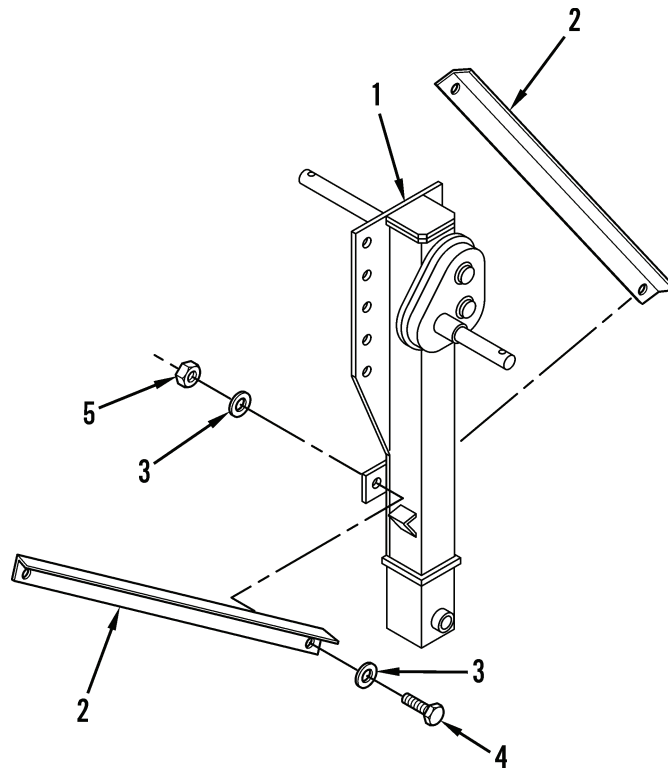

447-0201

Figure 1. Brackets (M871R and M871A1R Only).

2. Remove two bolts (Figure 2, Item 6) and self-locking nuts (Figure 2, Item 9) from cross drive shaft (Figure 2, Item 7). Discard self-locking nuts.
3. Remove eight bolts (Figure 2, Item 21) and locknuts (Figure 2, Item 22) from landing leg upper bracket. Discard locknuts.
4. Remove three bolts (Figure 2, Item 21) and locknuts (Figure 2, Item 22) from landing leg lower bracket and remove landing leg (Figure 2, Item 1) from semitrailer. Discard locknuts.
5. Remove hex screw (Figure 2, Item 12), self-locking nut (Figure 2, Item 9), and pin (Figure 2, Item 11) from landing gear shoe assembly. Discard self-locking nut.
6. Remove two hitch pins (Figure 2, Item 20), washers (Figure 2, Item 19), ties (Figure 2, Item 14), pins (Figure 2, Item 15), front shoe assembly (Figure 2, Item 13), and rear shoe assembly (Figure 2, Item 18) from landing leg (Figure 2, Item 1).
7. Remove two pop rivets (Figure 2, Item 17) and lanyards (Figure 2, Item 16) from landing leg (Figure 2, Item 1). Discard pop rivets (if required).
8. Repeat steps 3 thru 7 for remaining landing leg.
9. Remove bolt (Figure 2, Item 6), two washers (Figure 2, Item 8), and self-locking nut (Figure 2, Item 9) from landing leg crank (Figure 2, Item 10) and remove crank. Discard self-locking nut.

REMOVAL - CONTINUED

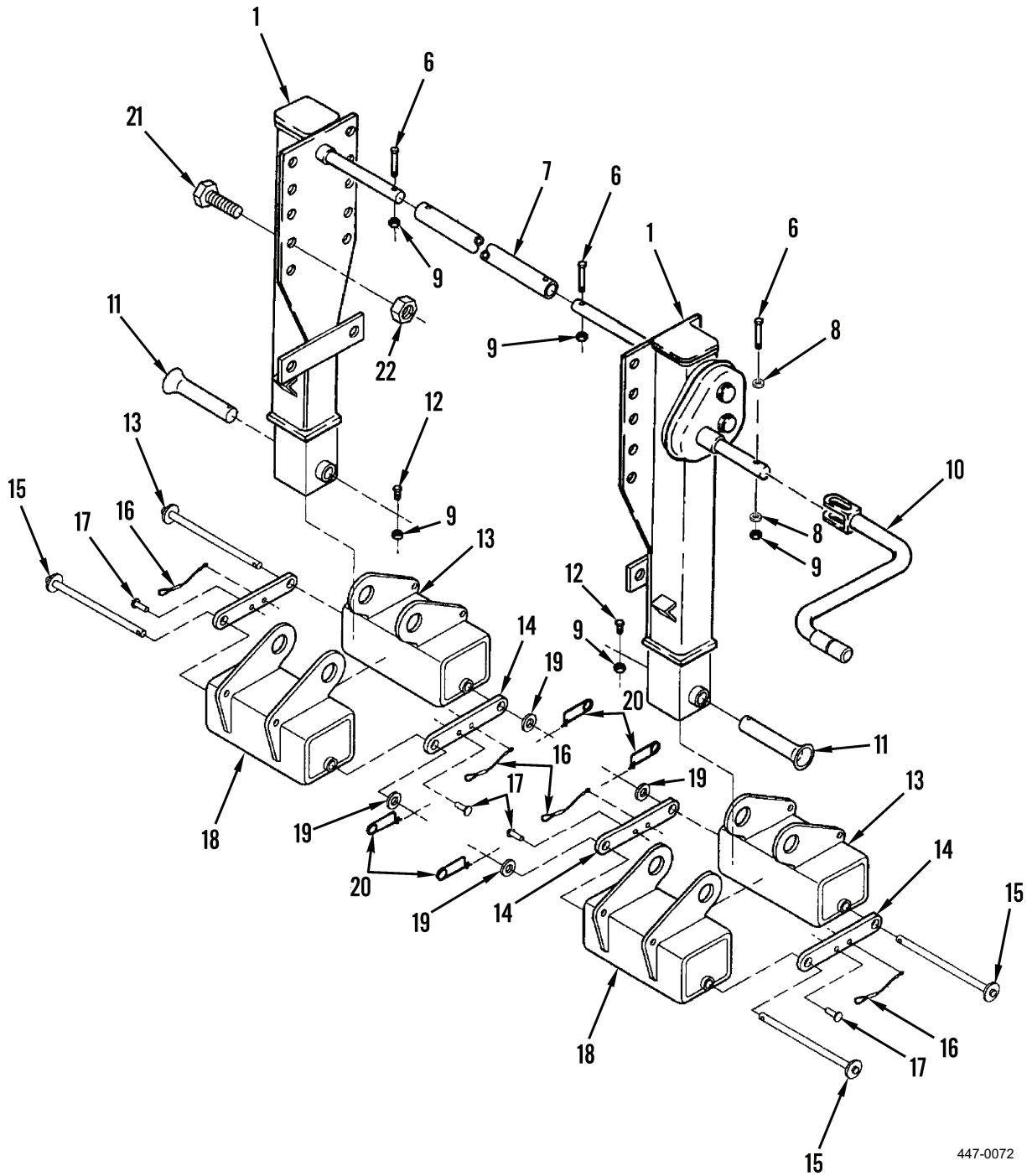

Figure 2. Landing Gear.

447-0072

END OF TASK

INSTALLATION

1. Install two lanyards (Figure 3, Item 16) into landing leg (Figure 3, Item 1) using two new pop rivets (Figure 3, Item 17).
2. Install front shoe assembly (Figure 3, Item 13) on rear shoe assembly (Figure 3, Item 18) using two hitch pins (Figure 3, Item 20), washers (Figure 3, Item 19), ties (Figure 3, Item 14), and pins (Figure 3, Item 15).
3. Install shoe assembly on landing leg (Figure 3, Item 1) using pin (Figure 3, Item 11), hex screw (Figure 3, Item 12), and new self-locking nut (Figure 3, Item 9).
4. Install landing leg (Figure 3, Item 1) onto landing leg upper bracket using eight bolts (Figure 3, Item 21) and new locknuts (Figure 3, Item 22).
5. Install landing leg (Figure 3, Item 1) onto landing leg lower bracket using three bolts (Figure 3, Item 21) and new locknuts (Figure 3, Item 22).
6. Repeat steps 1 thru 5 for remaining landing leg.
7. Install landing leg (Figure 3, Item 1) onto cross drive shaft (Figure 3, Item 7) using two bolts (Figure 3, Item 6) and new self-locking nuts (Figure 3, Item 9).
8. Install landing leg crank (Figure 3, Item 10) onto landing leg (Figure 3, Item 1) using bolt (Figure 3, Item 6), two washers (Figure 3, Item 8), and new self-locking nut (Figure 3, Item 9).

INSTALLATION - CONTINUED

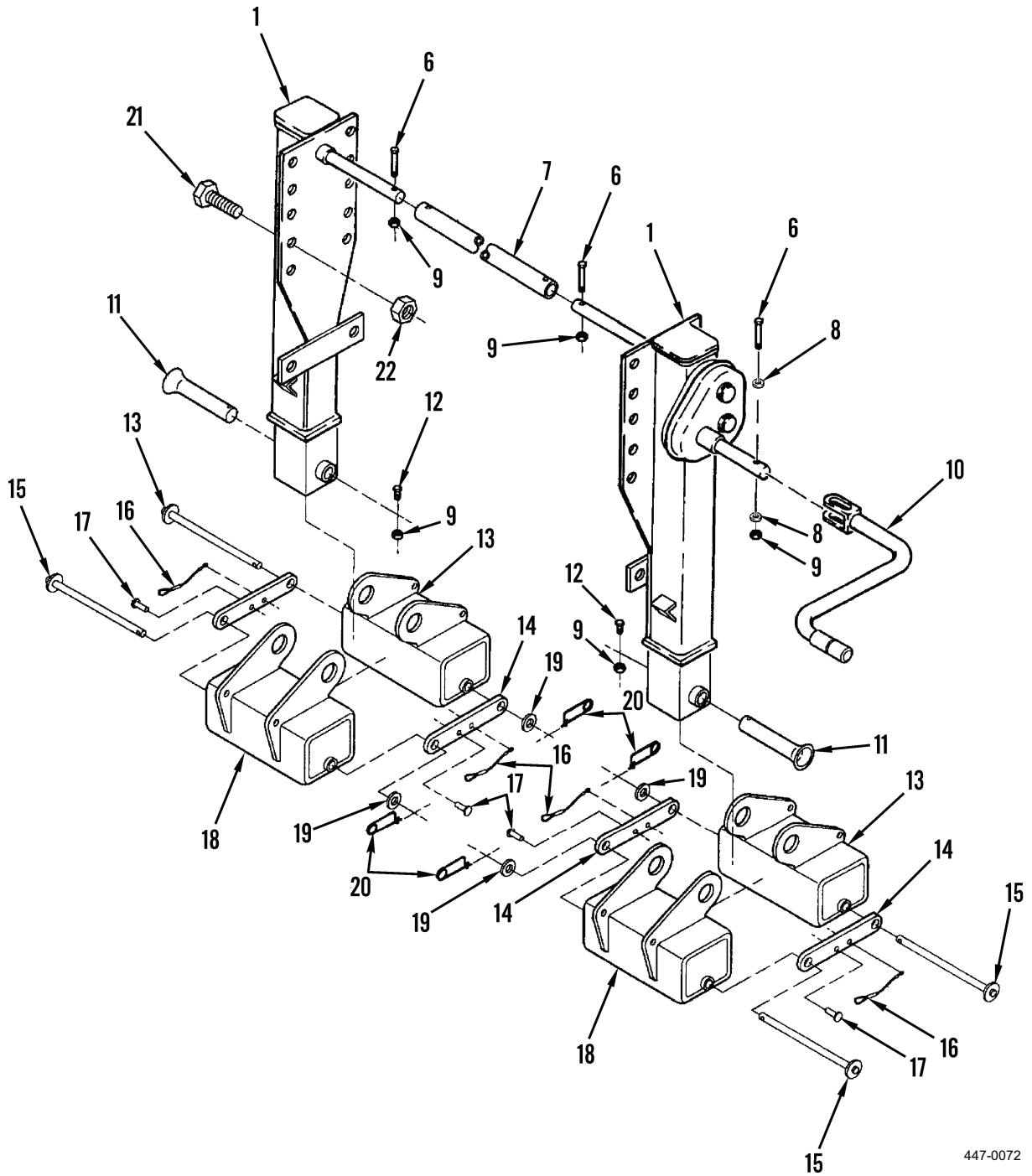

Figure 3. Landing Gear.

447-0072

INSTALLATION - CONTINUED**NOTE**

Step 9 applies only to the M871R and M871A1R semitrailers.

9. Install two brackets (Figure 4, Item 2), four screws (Figure 4, Item 4), eight washers (Figure 4, Item 3), and four new self-locking nuts (Figure 4, Item 5).

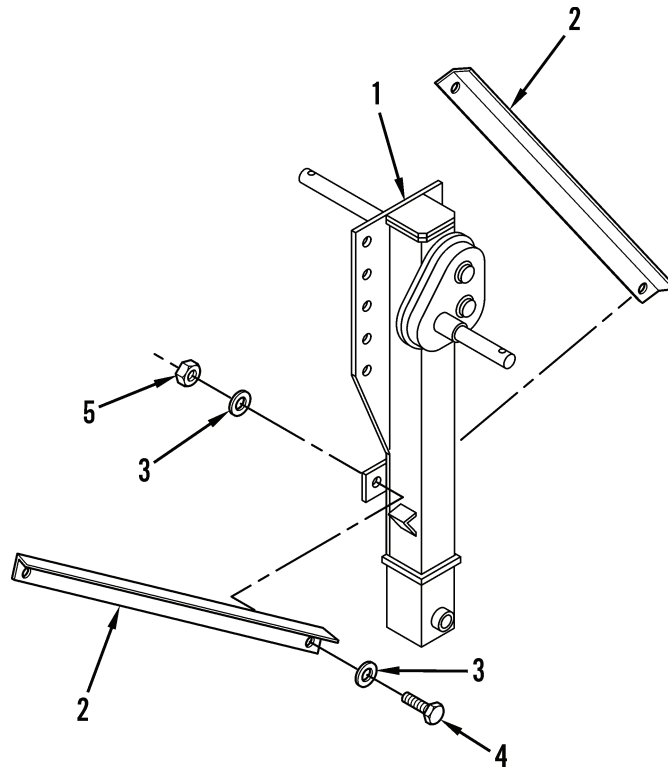

447-0201

Figure 4. Brackets (M871R and M871A1R Only).

END OF TASK**FOLLOW-ON TASKS**

1. Lubricate with 10-wt. oil.
2. Retract/extend landing legs to ensure smooth operation.
3. Emplace ground boards.
4. Lower landing legs.
5. Remove jack stands.
6. Connect semitrailer to prime mover.
7. Raise landing legs.
8. Remove/store chocks and ground boards.

END OF TASK**END OF WORK PACKAGE**

ORGANIZATIONAL MAINTENANCE
GROUND BOARDS REPLACEMENT
Removal, Installation

INITIAL SETUP
Maintenance Level

Organizational

Tools and Special Tools

Tool kit, general mechanic's (Item 4, WP 0082)

Materials/Parts

Cotter pin (4)

Equipment Conditions

Landing legs down

Semitrailer disconnected from prime mover

Tires chocked

WARNING

Watch hands and fingers when removing/installing ground boards. Hands/fingers could be pinched or cut if not careful when removing/installing ground boards.

NOTE

There are two ground boards and they are removed and installed the same way. This procedure covers one ground board.

REMOVAL

1. Remove two cotter pins (Figure 1, Item 1), washers (Figure 1, Item 2), and pin (Figure 1, Item 3) from semitrailer bracket. Discard cotter pins.
2. Remove clip (Figure 1, Item 4) and chain link (Figure 1, Item 5) from chain and remove ground board (Figure 1, Item 6) from semitrailer.

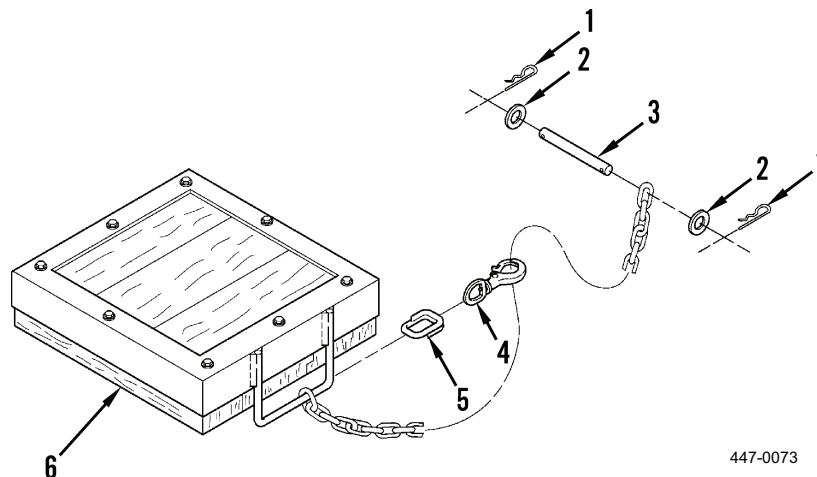

447-0073

Figure 1. Ground Boards.

END OF TASK

INSTALLATION

1. Install ground board (Figure 2, Item 6) onto semitrailer and install clip (Figure 2, Item 4) and chain link (Figure 2, Item 5).
2. Install two new cotter pins (Figure 2, Item 1), washers (Figure 2, Item 2), and one pin (Figure 2, Item 3) on semitrailer bracket.

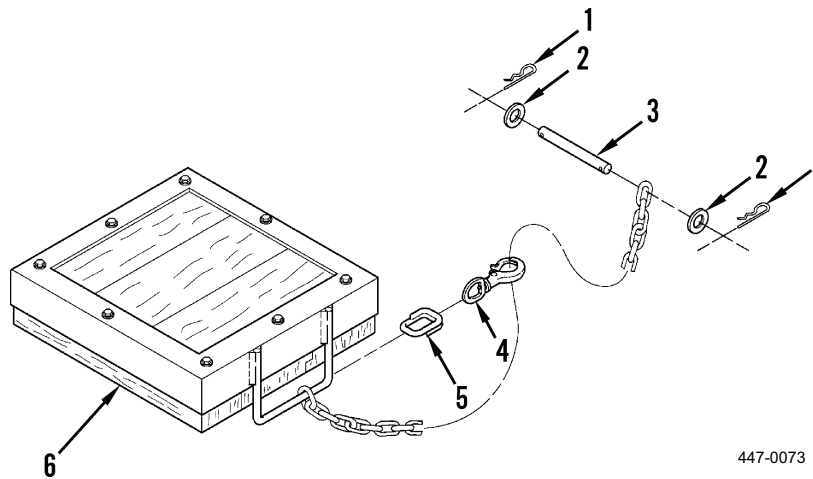

447-0073

Figure 2. Ground Boards.**END OF TASK****FOLLOW-ON TASKS**

1. Secure ground board (Figure 2, Item 6) using clip (Figure 2, Item 4) to take up slack in chain. Pull on handle to ensure ground board will not slide out during operation.
2. Connect semitrailer to prime mover.
3. Remove tire chocks.
4. Raise landing legs.

END OF TASK**END OF WORK PACKAGE**

ORGANIZATIONAL MAINTENANCE**BULKHEAD REPLACEMENT****Removal, Installation**

INITIAL SETUP**Maintenance Level**

Organizational

Personnel Required

Two

Tools and Special Tools

Tool kit, general mechanic's (Item 4, WP 0082)

Suitable lifting device, 850-lb capacity

References

WP 0064

Materials/Parts

Lockwasher (4)

Self-locking nut (4)

Equipment Conditions

Landing legs down

Semitrailer disconnected from prime mover

Tires chocked

Ground boards emplaced

Manifest box removed (WP 0058)

WARNING

Bulkhead weighs 557 lb (253 kg). Use suitable lifting device and two personnel to replace bulkhead. Failure to comply may result in injury or death to personnel.

REMOVAL

1. Attach lifting device to bulkhead (Figure 1, Item 1).
2. Remove four bolts (Figure 1, Item 4), lockwashers (Figure 1, Item 3), and nut/plates (Figure 1, Item 2). Discard lockwashers.

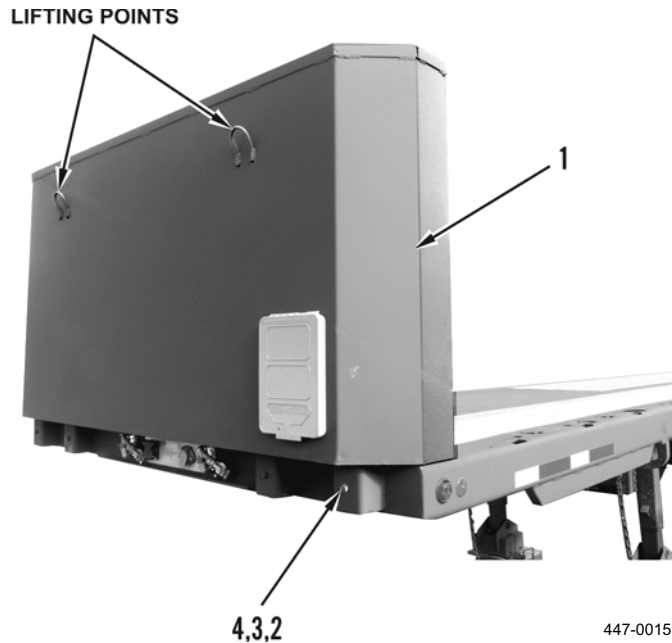
**Figure 1. Bulkhead.**

3. Remove four self-locking nuts (Figure 2, Item 7), washers (Figure 2, Item 6), bolts (Figure 2, Item 5), and bulkhead (Figure 2, Item 1). Discard self-locking nuts.

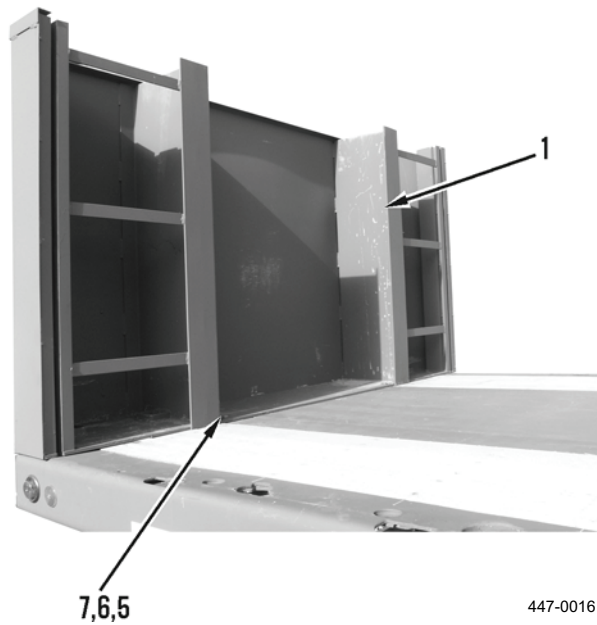
**Figure 2. Bulkhead.****END OF TASK**

INSTALLATION

1. Install bulkhead (Figure 2, Item 1), four bolts (Figure 2, Item 5), washers (Figure 2, Item 6), and new self-locking nuts (Figure 2, Item 7).
2. Install four nut/plates (Figure 1, Item 2), new lockwashers (Figure 1, Item 3), and bolts (Figure 1, Item 4).
3. Remove lifting device from bulkhead (Figure 1, Item 1).

END OF TASK**FOLLOW-ON TASKS**

1. Install manifest box (WP 0058).
2. Connect semitrailer to prime mover.
3. Raise landing legs.
4. Remove/store chocks and ground boards.
5. Install conspicuity tape (WP 0064).

END OF TASK**END OF WORK PACKAGE**

ORGANIZATIONAL MAINTENANCE
CORNER AND SIDE STAKES REPLACEMENT
Removal, Installation

INITIAL SETUP**Maintenance Level**

Organizational

References

WP 0004

Tools and Special Tools

Tool kit, general mechanic's (Item 4, WP 0082)

Equipment Conditions

Landing legs down
Semitrailer disconnected from prime mover
Side and rear panels removed
Tires chocked
Ground boards emplaced

Materials/Parts

Rivet (17)

NOTE

Refer to WP 0004 for position of corner and side stakes.

REMOVAL

1. Remove two links (Figure 1, Item 3), rivets (Figure 1, Item 4), lanyards (Figure 1, Item 5), and corner stakes (Figure 1, Item 2). Discard rivets.
2. Remove 15 links (Figure 1, Item 8), rivets (Figure 1, Item 6), lanyards (Figure 1, Item 7), and side stakes (Figure 1, Item 1). Discard rivets.

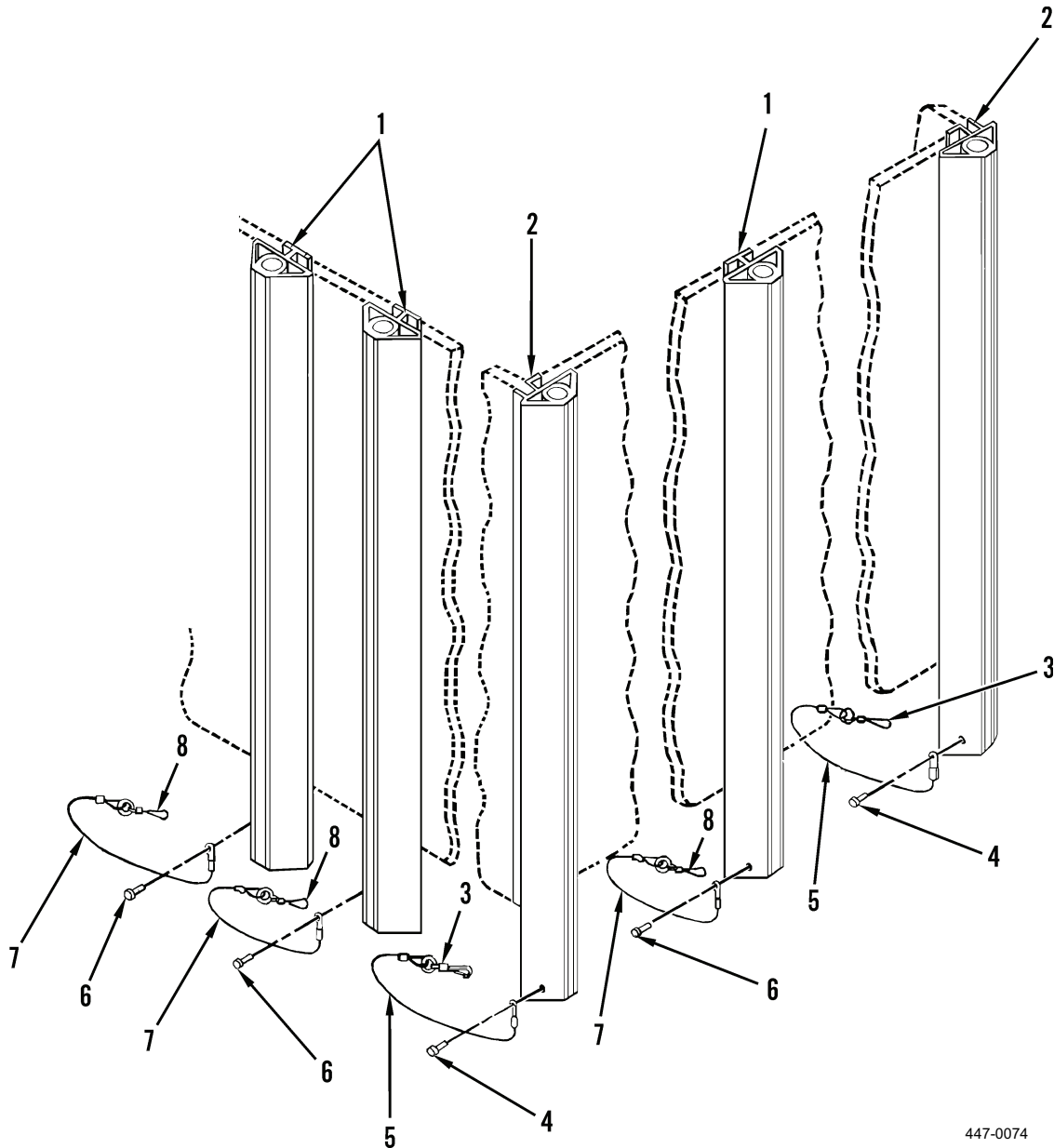

447-0074

Figure 1. Corner and Side Stakes.

END OF TASK

INSTALLATION**WARNING**

Ensure retaining hardware is present and serviceable. Failure to comply may result in injury to personnel.

1. Install two corner stakes (Figure 1, Item 2) using links (Figure 1, Item 3), new rivets (Figure 1, Item 4), and lanyards (Figure 1, Item 5).
2. Install 15 side stakes (Figure 1, Item 1) using links (Figure 1, Item 8), new rivets (Figure 1, Item 6), and lanyards (Figure 1, Item 7).

END OF TASK**FOLLOW-ON TASKS**

1. Install side/rear/front panels.
2. Ensure all stakes and panels are secured.
3. Connect semitrailer to prime mover.
4. Remove/store chocks and ground boards.
5. Raise landing legs.

END OF TASK**END OF WORK PACKAGE**

ORGANIZATIONAL MAINTENANCE
ANTISAIL MUD FLAPS REPLACEMENT
Removal, Installation

INITIAL SETUP**Maintenance Level**

Organizational

Tools and Special Tools

Tool kit, general mechanic's (Item 4, WP 0082)

Materials/Parts

Locknut (8)

Equipment Conditions

Landing legs down

Semitrailer disconnected from prime mover

Tires chocked

Ground boards emplaced

NOTE

There are two mud flaps and they are removed and installed the same way. This procedure covers one mud flap.

REMOVAL

Remove four locknuts (Figure 1, Item 1), washers (Figure 1, Item 2), screws (Figure 1, Item 5), antisail bracket (Figure 1, Item 4), and mud flap (Figure 1, Item 3) from semitrailer. Discard locknuts.

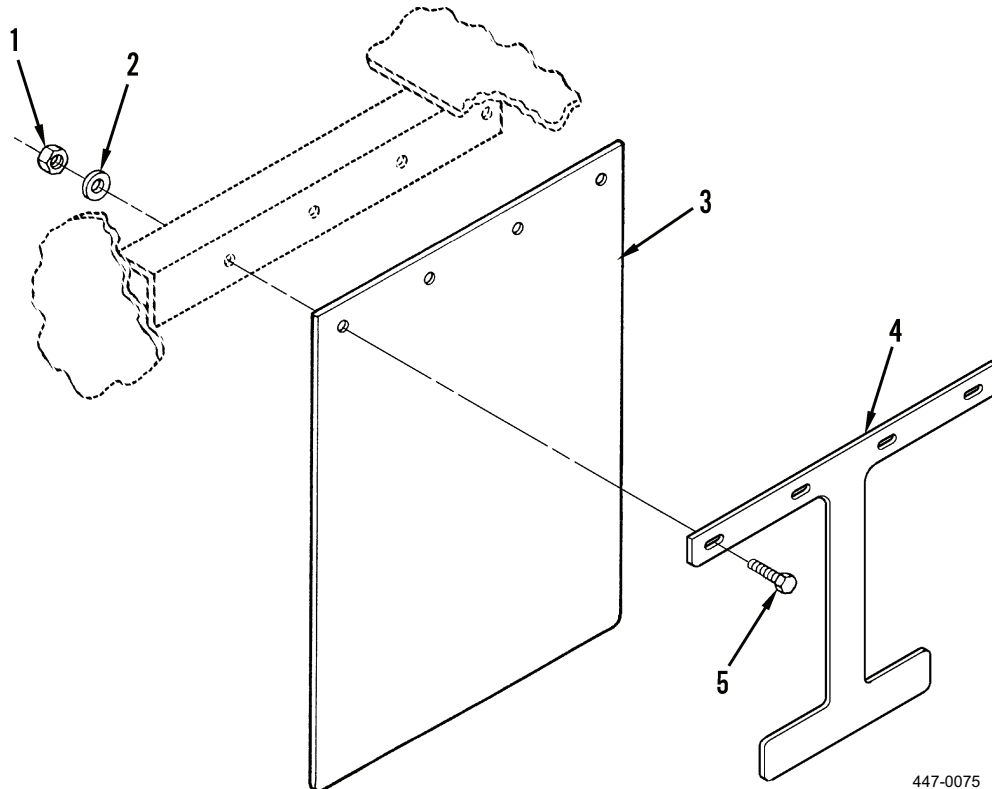

Figure 1. Antisail Mud Flaps.

447-0075

END OF TASK

INSTALLATION

Secure antisail bracket (Figure 2, Item 4) and mud flap (Figure 2, Item 3) to semitrailer using four new locknuts (Figure 2, Item 1), washers (Figure 2, Item 2), and screws (Figure 2, Item 5).

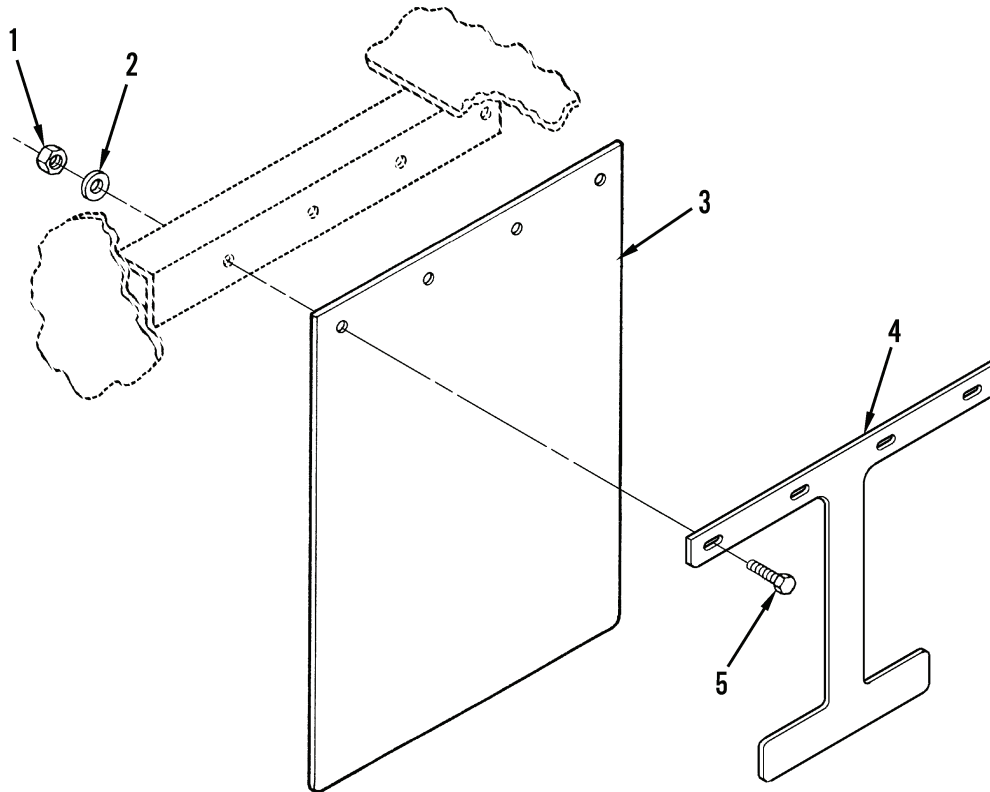

447-0075

Figure 2. Antisail Mud Flaps.

END OF TASK**FOLLOW-ON TASKS**

1. Connect semitrailer to prime mover.
2. Raise landing legs.
3. Remove/secure chocks and ground boards.

END OF TASK**END OF WORK PACKAGE**

ORGANIZATIONAL MAINTENANCE
FLOOR DECK BOARDS REPLACEMENT (M871R AND M871A1R)
Removal, Installation

INITIAL SETUP**Maintenance Level**

Organizational

Tools and Special Tools

Tool kit, general mechanic's (Item 4, WP 0082)
Shop equipment, common No. 1 (Item 1, WP 0082)
Bit, hex, insert, (Item 10, WP 0082)

Materials/Parts

Linseed oil (Item 9, WP 0085)
Rust inhibitor (Item 14, WP 0085)
UV wood protector (Item 18, WP 0085)

Equipment Conditions

Landing legs down
Semitrailer disconnected from prime mover
Tires chocked
Ground boards emplaced

REMOVAL

1. Measure board (Figure 1, Item 1) to be replaced.
2. Remove screws (Figure 1, Item 2) as needed to free board (Figure 1, Item 1).
3. Lift board (Figure 1, Item 1) away from frame.
4. Repeat as needed for any other boards needing replacement.
5. Grind flush all screws that have not been removed from crossmembers.
6. Properly dispose of screws and boards.

END OF TASK**INSTALLATION**

1. If paint has worn off crossmembers, re-coat with rust inhibitor and CARC paint.

NOTE

- Lift and tilt boards so they properly fit in the ship-lapped grooves and rails as shown in Figure 1.
 - Because all decks are not the same, MINOR trimming of boards may be required. However, DO NOT MODIFY a board to make it fit — follow Figure 1 and the ship-lap positioning.
 - If necessary, pre-mark (Figure 1, Item A) crossmembers so their location can be identified after boards have been laid in place.
2. Place boards (Figure 1, Item 1) into position.

NOTE

- If a finger-joint in the board overlays a crossmember, screws may be installed though the finger-joint. DO NOT try to cut the board so the finger-joint does not lay over a crossmember.
 - Steps 3 and 4 can be accomplished in one operation by using self-tapping deck screws.
3. Drill boards and crossmembers at the same time with 9/32-in. holes to ensure matchup of holes. Countersink holes in boards.
 4. Drive screws (Figure 1, Item 2) through boards into crossmembers using two screws per crossmember that board overlays.
 5. Repeat steps 2 thru 4 for other boards that were removed.
 6. Treat new boards with boiled linseed oil or a UV wood protector.

INSTALLATION - CONTINUED

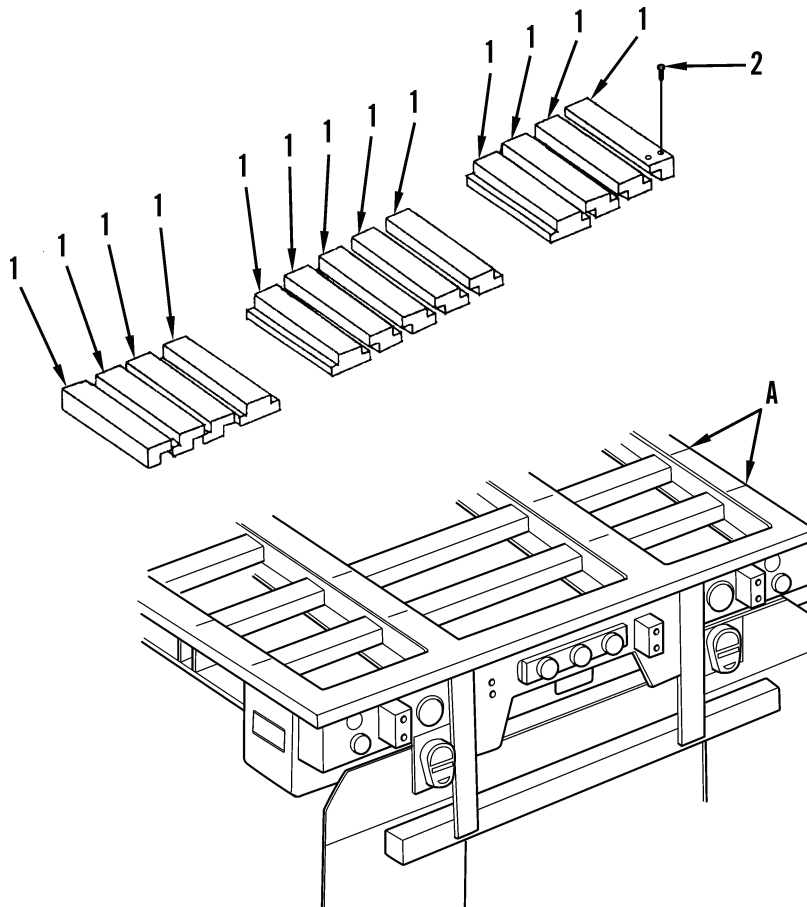

447-0212-1

Figure 1. Floor Deck Boards.

END OF TASK**FOLLOW-ON TASKS**

1. Connect semitrailer to prime mover.
2. Raise landing legs.
3. Remove/store chocks and ground boards.

END OF TASK**END OF WORK PACKAGE**

ORGANIZATIONAL MAINTENANCE
FLOOR DECK BOARDS REPLACEMENT (M871A2R)
Removal, Installation

INITIAL SETUP**Maintenance Level**

Organizational

Tools and Special Tools

Tool kit, general mechanic's (Item 4, WP 0082)
Shop equipment, common No. 1 (Item 1, WP 0082)
Bit, hex, insert, (Item 10, WP 0082)

Materials/Parts

Linseed oil (Item 9, WP 0085)
Rust inhibitor (Item 14, WP 0085)
UV wood protector (Item 18, WP 0085)

Equipment Conditions

Landing legs down
Semitrailer disconnected from prime mover
Tires chocked
Ground boards emplaced

REMOVAL

1. Measure board (Figure 1, Item 1) to be replaced.
2. Remove screws (Figure 1, Item 2) as needed to free board (Figure 1, Item 1).
3. Lift board (Figure 1, Item 1) away from frame.
4. Repeat as needed for any other boards needing replacement.
5. Grind flush all screws that have not been removed from crossmembers.
6. Properly dispose of screws and boards

INSTALLATION

1. If paint has worn off crossmembers, re-coat with rust inhibitor and CARC paint.

NOTE

- Lift and tilt boards so they properly fit in the ship-lapped grooves and rails as shown in Figure 1.
 - Because all decks are not the same, MINOR trimming of boards may be required. However, DO NOT MODIFY a board to make it fit — follow Figure 1 and the ship-lap positioning.
 - If necessary, pre-mark (Figure 1, Item A) crossmembers so their location can be identified after boards have been laid in place.
2. Place boards (Figure 1, Item 1) into position.

NOTE

- If a finger-joint in the board overlays a crossmember, screws may be installed though the finger-joint. DO NOT try to cut the board so the finger-joint does not lay over a crossmember.
 - Steps 3 and 4 can be accomplished in one operation by using self-tapping deck screws.
3. Drill boards and crossmembers at the same time with 9/32-in. holes to ensure matchup of holes. Countersink holes in boards.
 4. Drive screws (Figure 1, Item 2) through boards into crossmembers using two screws per crossmember that board overlays.
 5. Repeat steps 2 thru 4 for other boards that were removed.
 6. Treat new boards with boiled linseed oil or a UV wood protector.

INSTALLATION - CONTINUED

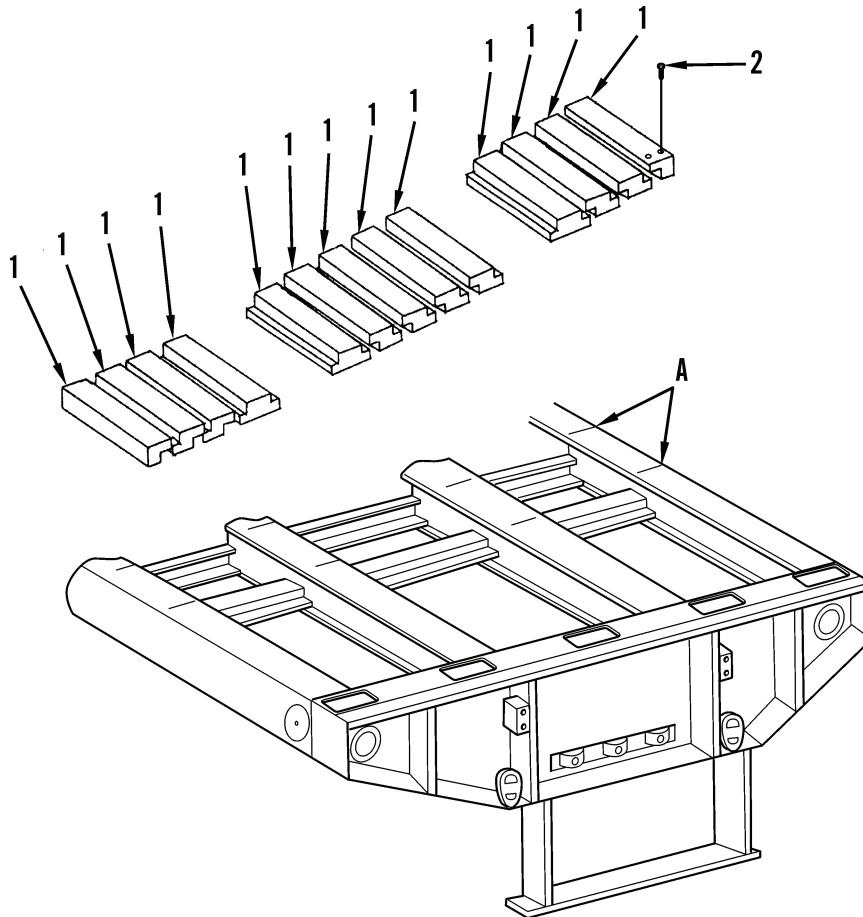

447-0213-1

Figure 1. Floor Deck Boards.

END OF TASK**FOLLOW-ON TASKS**

1. Connect semitrailer to prime mover.
2. Raise landing legs.
3. Remove/store chocks and ground boards.

END OF TASK**END OF WORK PACKAGE**

ORGANIZATIONAL MAINTENANCE**STOWAGE BOX REPLACEMENT****Removal, Installation**

INITIAL SETUP**Maintenance Level**

Organizational

References

TM 9-237

WP 0070

Tools and Special Tools

Tool kit, general mechanic's (Item 4, WP 0082)

Suitable lifting device, 300-lb capacity

Equipment Conditions

Landing legs down

Semitrailer disconnected from prime mover

Tires chocked

Ground boards emplaced

Stowage box emptied

Materials/Parts

Oil, lubricating (Item 11, WP 0085)

Locknut (8)

Nonmetallic seal (A/R)

Personnel RequiredTwo

WARNING

Stowage box weighs 195 lb (88 kg). Use suitable lifting device and two personnel to replace stowage box. Failure to comply may result in injury or death to personnel.

REMOVAL

1. Remove 8 locknuts (Figure 1, Item 3), 16 washers (Figure 1, Item 2), and 8 bolts (Figure 1, Item 1) from stowage box (Figure 1, Item 4). Discard locknuts.
2. Remove stowage box (Figure 1, Item 4) from side panel brackets (Figure 1, Item 6).

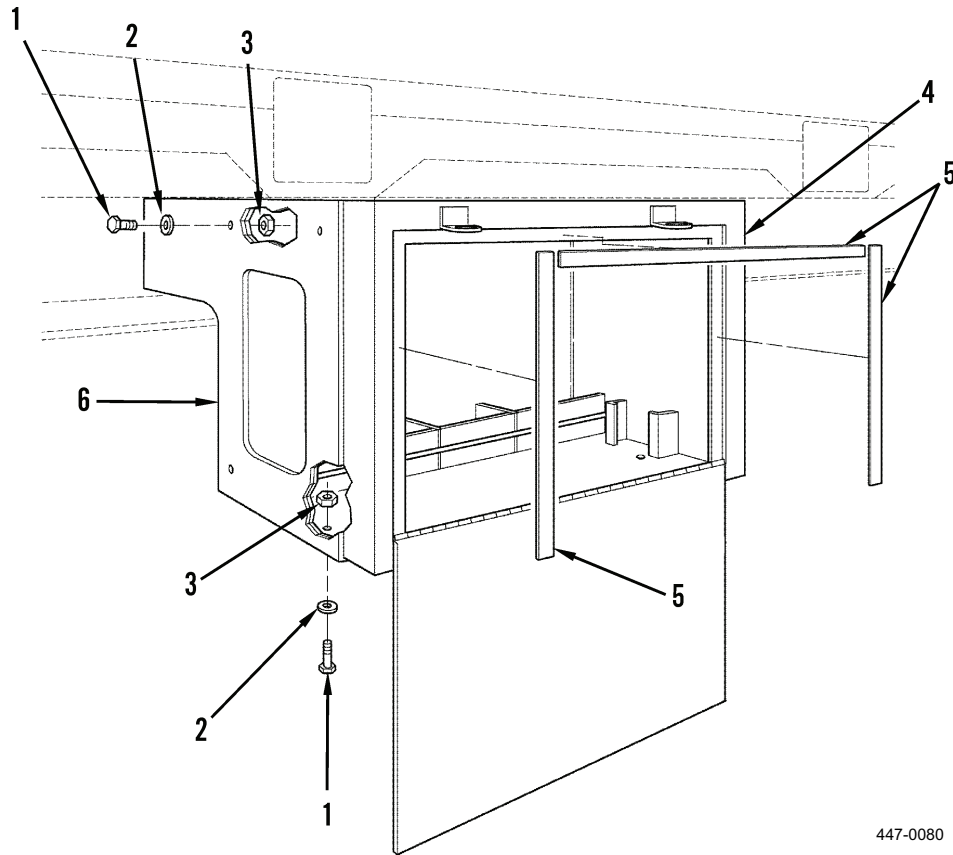

447-0080

Figure 1. Stowage Box.**END OF TASK****INSTALLATION****NOTE**

- Replacement of stowage box side panels is a Direct Support function (see WP 0070). See TM 9-237 for welding instructions.
 - Paint entire box before installation of nonmetallic seal if necessary.
1. Place stowage box (Figure 1, Item 4) on side panel brackets (Figure 1, Item 6). Set on side, slide in box, and then bolt.
 2. Install stowage box (Figure 1, Item 4), 8 bolts (Figure 1, Item 1), 16 washers (Figure 1, Item 2), and 8 new locknuts (Figure 1, Item 3).
 3. Install new nonmetallic seal (Figure 1, Item 5) as needed onto exterior lip of storage box (Figure 1, Item 4).

END OF TASK

FOLLOW-ON TASKS

1. Lubricate hinges with oil.
2. Replace BII items in stowage box and secure.
3. Connect semitrailer to prime mover.
4. Raise landing legs.
5. Remove/store chocks and ground boards.

END OF TASK**END OF WORK PACKAGE**

ORGANIZATIONAL MAINTENANCE
MANIFEST BOX REPLACEMENT
Removal, Installation

INITIAL SETUP
Maintenance Level

Organizational

Tools and Special Tools

Tool kit, general mechanic's (Item 4, WP 0082)

Materials/Parts

Locknut (4)

Equipment Conditions

Landing legs down

Semitrailer disconnected from prime mover

Tires chocked

Ground boards emplaced

REMOVAL

Remove four locknuts (Figure 1, Item 3), washers (Figure 1, Item 2), bolts (Figure 1, Item 4), and manifest box (Figure 1, Item 1) from semitrailer. Discard locknuts.

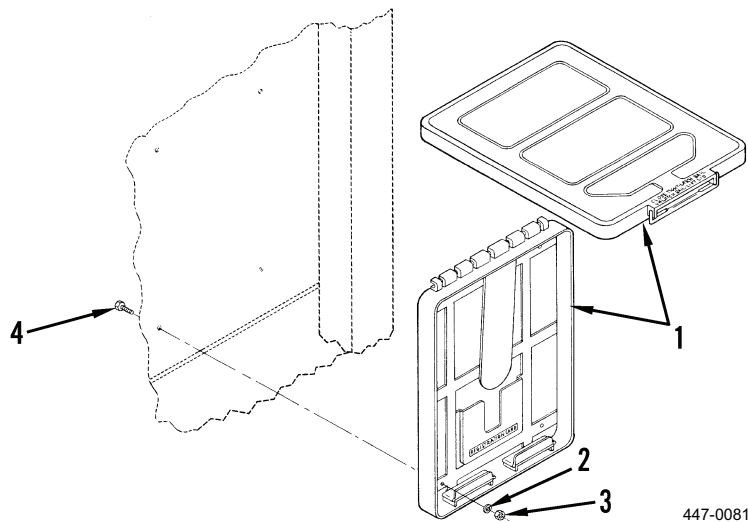

Figure 1. Manifest Box.

END OF TASK
INSTALLATION

Install manifest box (Figure 1, Item 1), four bolts (Figure 1, Item 4), washers (Figure 1, Item 2), and new locknuts (Figure 1, Item 3).

END OF TASK

FOLLOW-ON TASKS

1. Connect semitrailer to prime mover.
2. Raise landing legs.
3. Remove/store chocks and ground boards.

END OF TASK**END OF WORK PACKAGE**

ORGANIZATIONAL MAINTENANCE
LADDER BRACKET REPLACEMENT
Removal, Installation

INITIAL SETUP
Maintenance Level

Organizational

Tools and Special Tools

Tool kit, general mechanic's (Item 4, WP 0082)

Materials/Parts

Locknut (4)

Equipment Conditions

Landing legs down
 Semitrailer disconnected from prime mover
 Tires chocked
 Ground boards emplaced
 Ladder removed (WP 0004)

REMOVAL

Remove four locknuts (Figure 1, Item 1), bolts (Figure 1, Item 2), eight washers (Figure 1, Item 3), and bracket (Figure 1, Item 4). Discard locknuts.

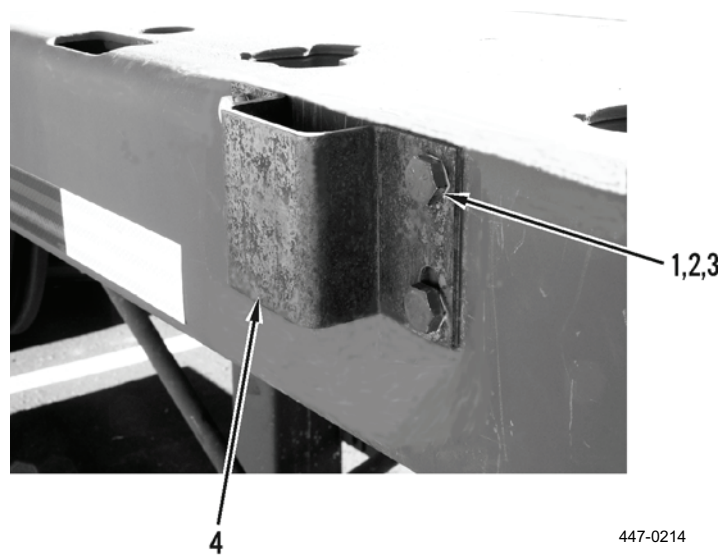

Figure 1. Ladder Bracket.

END OF TASK**INSTALLATION**

Install bracket (Figure 1, Item 4), eight washers (Figure 1, Item 3), four bolts (Figure 1, Item 2), and new locknuts (Figure 1, Item 1).

END OF TASK

FOLLOW-ON TASKS

1. Install ladder (WP 0004).
2. Connect semitrailer to prime mover.
3. Raise landing legs.
4. Remove/store chocks and ground boards.

END OF TASK**END OF WORK PACKAGE**

ORGANIZATIONAL MAINTENANCE
REFLECTORS REPLACEMENT**Removal, Installation****INITIAL SETUP****Maintenance Level**

Organizational

Tools and Special Tools

Tool kit, general mechanic's (Item 4, WP 0082)

Materials/Parts

Antiseize compound (Item 1, WP 0085)

Self-tapping screw (8)

Equipment Conditions

Landing legs down

Semitrailer disconnected from prime mover

Tires chocked

Ground boards emplaced

REMOVAL**NOTE**

There are four amber reflectors and four red reflectors and they are all removed and installed the same way. This procedure covers one reflector.

Remove self-tapping screw (Figure 1, Item 2) and amber or red reflector (Figure 1, Item 1) from semitrailer. Discard self-tapping screw.

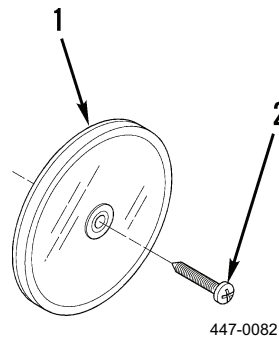
**Figure 1. Reflectors.****END OF TASK****INSTALLATION**

Apply antiseize compound to new self-tapping screw (Figure 1, Item 2) and install amber or red reflector (Figure 1, Item 1).

END OF TASK

FOLLOW-ON TASKS

1. Connect semitrailer to prime mover.
2. Raise landing legs.
3. Remove/store chocks and ground boards.

END OF TASK**END OF WORK PACKAGE**

ORGANIZATIONAL MAINTENANCE
DECALS AND DATA PLATES REPLACEMENT
Removal, Installation, Decals and Data Plates

INITIAL SETUP**Maintenance Level**

Organizational

Tools and Special Tools

Tool kit, general mechanic's (Item 4, WP 0082)

Materials/Parts

Rivet (8)

Equipment Conditions

Landing legs down

Semitrailer disconnected from prime mover

Tires chocked

Ground boards emplaced

REMOVAL**NOTE**

Transcribe pertinent information onto new decals and data plates.

1. Drill out/chisel four rivets (Figure 2, Item 9) and remove lifting/tiedown data plate (Figures 2, 3, and 5, Item 10) and lubrication data plate (Figures 2 and 5, Item 8) from semitrailer. Discard rivets.
2. Remove automatic slack adjusters notice decal (Figures 1 and 4, Item 5), hubs information/warning decal (Figures 1 and 4, Item 6), two UID decals (Figures 1, 4, and 5, Item 3), inspection decal (Figures 1 and 4, Item 2), gross axle weight rating decal (Figures 1 and 5, Item 4), final inspection decal (Figures 1 and 4, Item 1), and torque decal (Figures 2 and 5, Item 7) from semitrailer. Discard labels.

END OF TASK**INSTALLATION**

1. Install new torque decal (Figures 2 and 5, Item 7), final inspection decal (Figures 1 and 4, Item 1), gross axle weight rating decal (Figures 1 and 5, Item 4), inspection decal (Figures 1 and 4, Item 2), two UID decals (Figures 1, 4, and 5, Item 3), hubs information/warning decal (Figures 1 and 4, Item 6), and automatic slack adjusters notice decal (Figures 1 and 4, Item 5) on semitrailer.
2. Install lubrication data plate (Figures 2 and 5, Item 8) and lifting/tiedown data plate (Figures 2, 3, and 5, Item 10) using eight new rivets (Figure 2, Item 9).

END OF TASK

DECALS AND DATA PLATES

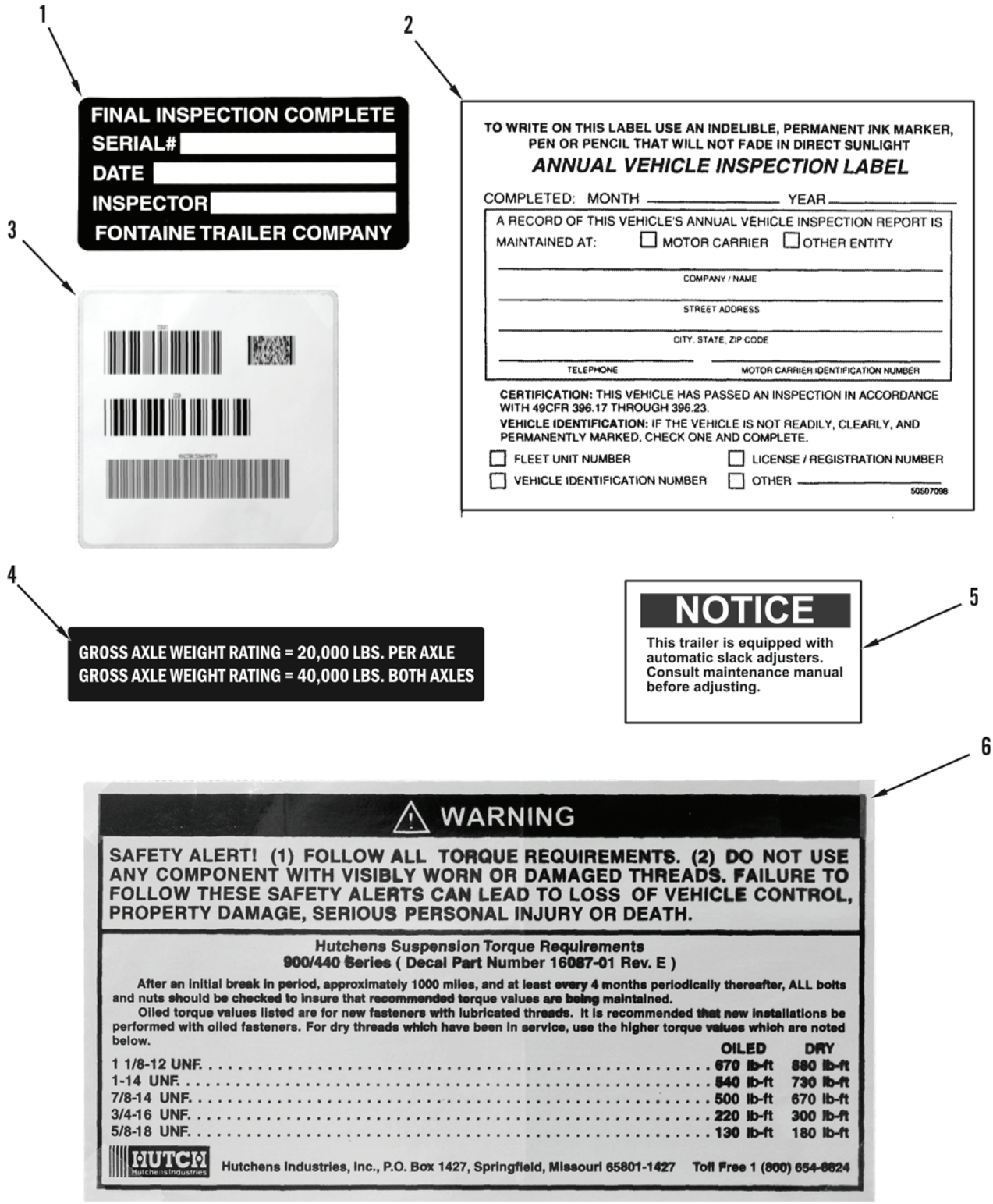
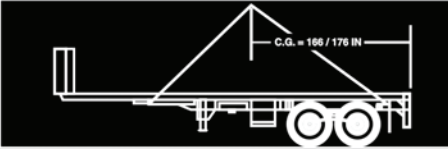

Figure 1. Decals.

DECALS AND DATA PLATES - CONTINUED

10

SEMITRAILER, FLATBED BREAKBULK/CONTAINER TRANSPORTER, 22 1/2 TON, M871R



C.G. = 166 / 176 IN

GAWR & GAWR
 GVWR BASED ON SPEED LIMITATION OF 55 MPH
 61000 #
 GAWR TIRE PRESSURE 92 PSI COLD WITH 11 R22.5 16 Ply (H)
 19360 #

THIS VEHICLE CONFORMS TO ALL APPLICABLE FEDERAL MOTOR VEHICLE SAFETY STANDARDS IN EFFECT ON THE DATE OF MANUFACTURE

	WEIGHT DISTRIBUTION	
	EMPTY	LOADED (MAX)
AXLES	3770 LBS	35,655 LBS
LANDING GEAR	3520 LBS	40,434 LBS
KINGPIN	5860 LBS	24,975 LBS

LIFTING DATA
 ALL CARGO IN EITHER BULK OR CONTAINER MODE MUST BE EVENLY DISTRIBUTED ON TRAILER WHEN LIFTING WITH LIFTING EYES. SLINGING THROUGH A CONTAINER CAN ONLY BE DONE WHEN TRAILER IS LOADED WITH A 20 FT CONTAINER. LIFTING CAPACITY OF EACH LIFTING EYE IS 40,000 LBS

TIE DOWN DATA
 EACH TIE DOWN MAY BE USED FOR BOTH LONGITUDINAL AND LATERAL RESTRAINT. RESTRAINING CAPACITY OF EACH TIE DOWN IS 61,000 LBS

DATE OF MANUFACTURE: _____ **MFD BY:** SOUTHWEST TRUCK BODY CO. ST. LOUIS, MO
VEHICLE REG. NO. _____ **MODEL:** M871
SERIAL NO. _____ **NSN:** 2330-01-122-6779 **CONTRACT:** DAAE07-79-C-60A2

RESET BY: FONTAINE TRAILER MILITARY PRODUCTS 100 FONTAINE RD. PRINCETON, KY 42445
CONTRACT: DAAE07-98-DT064
REBUILD DATE: _____
DELIVERY DATE: _____

50970054

9

LUBRICATION CHART
SEMI-TRAILER, FLATBED, 22.5 TON
M871R, M871A1R, M871A2R

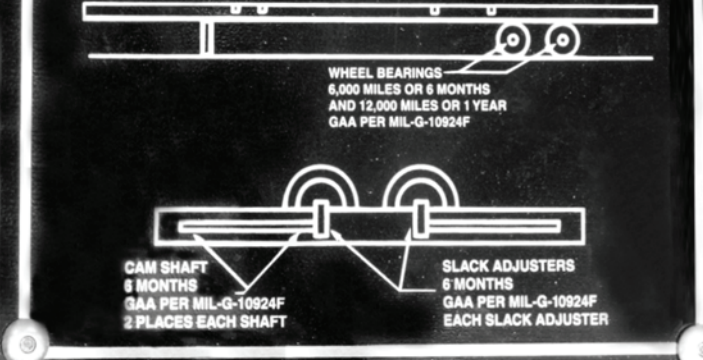

WHEEL BEARINGS
 6,000 MILES OR 6 MONTHS
 AND 12,000 MILES OR 1 YEAR
 GAA PER MIL-G-10924F

CAM SHAFT
 6 MONTHS
 GAA PER MIL-G-10924F
 2 PLACES EACH SHAFT

SLACK ADJUSTERS
 6 MONTHS
 GAA PER MIL-G-10924F
 EACH SLACK ADJUSTER

7

! WARNING

HUBS (FOR PILOT MOUNTED DISC WHEELS)
 8 - 10 STUD HUBS
 APPLIES TO M22 X 1.5 STUDS / TWO PIECE FLANGE NUT.

All threads are right hand metric.
 Tighten Flange Nuts to 50 ft. lb. using sequence shown.
 Check Disc-Wheels for proper positioning on pads and proper seating against flange.
 Tighten Flange Nuts to recommended torque using sequence shown.
 RECOMMENDED TORQUE: 450 - 500 FT. LBS.



10 1 8
 3 5 2 6
 7 3 4 4
 5 8 4
 7 2 9

1. Read and understand this warning and the Installation, Service and Safety Instruction Manual to understand all safety precautions, proper operation, and maintenance of your Webb hub. Failure to do so could result in death or serious injury and could result in a compromise of your vehicles safe operation through loss or failure of a wheel or the compromise of the braking system. Copies of the Installation, Service and Safety Instruction Manual are available, free of charge, from Webb Wheel Products, Inc. upon request.

2. Always use a properly calibrated torque wrench to assure proper torque. Under torque and over torque can cause thread and/or nut damage and could result in the loss of a wheel. Failure to ensure proper torque could result in death or serious injury and could shorten the expected life of this product.

3. Recheck torque after the first 50 to 100 miles of service. Parts may seat naturally, causing the torque to drop. A drop in torque could result in the loss of a wheel. Proper torque is essential to avoid damage or compromise of your vehicles safety. Failure to ensure proper torque could result in death or serious injury.

WEBB Webb Wheel Products
 2310 INDUSTRIAL DRIVE, S.W.
 CULLMAN, ALABAMA 35055
 256-739-6660 WWW.WEBBWHEEL.COM

82092 (C)

Figure 2. Decal, Data Plates, and Rivets.

DECALS AND DATA PLATES - CONTINUED

10

SEMITRAILER, FLATBED BREAKBULK/CONTAINER TRANSPORTER, 22 1/2 TON, M871A1R

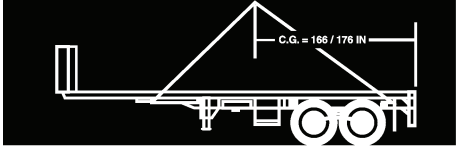

GVWR & GAWR
 GVWR BASED ON SPEED LIMITATION OF 55 MPH: 61000 #
 GAWR TIRE PRESSURE 82 PSI COLD WITH 11 R22.5 16 Ply (H): 19360 #

THIS VEHICLE CONFORMS TO ALL APPLICABLE FEDERAL MOTOR VEHICLE SAFETY STANDARDS IN EFFECT ON THE DATE OF MANUFACTURE

LIFTING DATA		WEIGHT DISTRIBUTION	
ALL CARGO IN EITHER BULK OR CONTAINER MODE MUST BE EVENLY DISTRIBUTED ON TRAILER WHEN LIFTING WITH LIFTING EYES. SLINGING THROUGH A CONTAINER CAN ONLY BE DONE WHEN TRAILER IS LOADED WITH A 20 FT CONTAINER. LIFTING CAPACITY OF EACH LIFTING EYE IS 40,000 LBS		EMPTY	LOADED (MAX)
TIE DOWN DATA EACH TIE DOWN MAY BE USED FOR BOTH LONGITUDINAL AND LATERAL RESTRAINT. RESTRAINING CAPACITY OF EACH TIE DOWN IS 61,000 LBS		AXLES	9770 LBS 35,685 LBS
		LANDING GEAR	9520 LBS 40,434 LBS
		KINGPIN	5860 LBS 24,975 LBS
DATE OF MANUFACTURE: <input type="text"/>		SHIPPING CUBE: 2,163 CU FT MAXIMUM PAYLOAD: 45,000 LBS SHIPPING WEIGHT: 15,630 LBS	
VEHICLE REG. NO. <input type="text"/>		RESET BY: FONTAINE TRAILER MILITARY PRODUCTS 100 FONTAINE RD. PRINCETON, KY 42445	
SERIAL NO. <input type="text"/>		CONTRACT: DAAE07-98-DT064 REBUILD DATE: <input type="text"/> DELIVERY DATE: <input type="text"/>	

MFGD BY: SHOALS AMERICAN INDUSTRIES
 338 WASHINGTON ST.
 MUSCLE SHOALS, AL

MODEL: M871A1
 NSN: 2330-01-226-0701
 CONTRACT: DAAE07-85-C-J058

50976055

SEMITRAILER, FLATBED BREAKBULK/CONTAINER TRANSPORTER, 22 1/2 TON, M871A2R

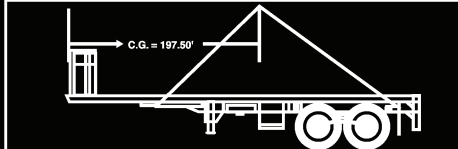

GVWR & GAWR
 GVWR BASED ON SPEED LIMITATION OF 55 MPH: 61000 #
 GAWR TIRE PRESSURE 82 PSI COLD WITH 11 R22.5 16 Ply (H): 19360 #

THIS VEHICLE CONFORMS TO ALL APPLICABLE FEDERAL MOTOR VEHICLE SAFETY STANDARDS IN EFFECT ON THE DATE OF MANUFACTURE

LIFTING DATA		WEIGHT DISTRIBUTION	
ALL CARGO IN EITHER BREAKBULK OR CONTAINER MODE MUST BE EVENLY DISTRIBUTED ON TRAILER, PROOFED VERTICAL COMPONENT OF LIFT DEVICE = 36250#		EMPTY	LOADED (MAX)
TIE DOWN DATA VEHICLE TIE DOWN DEVICES CAN BE USED IN ANY DIRECTION MAX ANGLE OF TIE DOWN - 45 DEGREES MAXIMUM PROOFED CAPACITY = 60000# EA CARGO TIEDOWN RINGS RATED AT 10000# EA		AXLES	8140 36656
DATE OF MANUFACTURE: <input type="text"/>		LANDING GEAR	6420 50000
		KINGPIN	3570 25000
VEHICLE REG. NO. <input type="text"/>		SHIPPING CUBE: 1822 CU FT MAXIMUM PAYLOAD: 45000 LBS SHIPPING WEIGHT: 12240 LBS	
SERIAL NO. <input type="text"/>		RESET BY: FONTAINE TRAILER MILITARY PRODUCTS 100 FONTAINE RD. PRINCETON, KY 42445	
CONTACT# DAAE07-88-C-J097		CONTRACT: DAAE07-98-DT064 REBUILD DATE: <input type="text"/> DELIVERY DATE: <input type="text"/>	

MFGD BY: DYNAWELD, INC.
 29W414 N. AURORA RD
 NAPERVILLE, ILL. 60563

50970651

447-0268

Figure 3. Data Plates.

DECALS AND DATA PLATES - CONTINUED

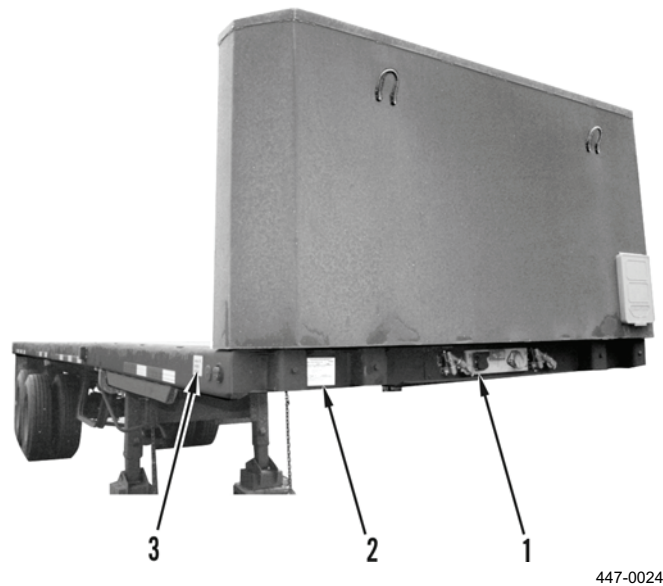

Figure 4. Location of Decals and Data Plates.

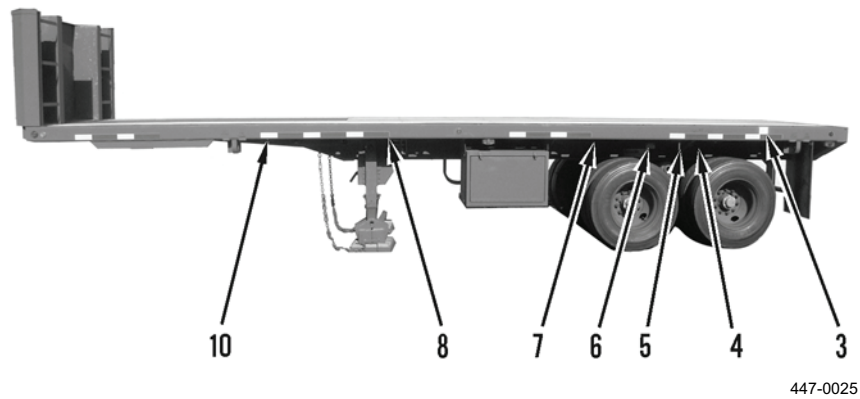

Figure 5. Location of Decals and Data Plates.

END OF TASK

FOLLOW-ON TASKS

1. Connect semitrailer to prime mover.
2. Raise landing legs.
3. Remove/store chocks and ground boards.

END OF TASK

END OF WORK PACKAGE

ORGANIZATIONAL MAINTENANCE
ABS WARNING LIGHT REPLACEMENT
Removal, Installation

INITIAL SETUP**Maintenance Level**

Organizational

Tools and Special Tools

Tool kit, general mechanic's (Item 4, WP 0082)

Materials/Parts

Grease, dielectric (silicone) (Item 7, WP 0085)

Grommet

Equipment Conditions

Landing legs down

Semitrailer disconnected from prime mover

Tires chocked

Ground boards emplaced

WARNING

Disconnect electrical power source before performing any maintenance on the electrical system.
Failure to comply could result in injury to personnel.

REMOVAL

1. Remove grommet (Figure 1, Item 2) from ABS warning light (Figure 1, Item 1). Discard grommet.
2. Disconnect connectors from back of ABS warning light (Figure 1, Item 1) and remove ABS warning light (Figure 1, Item 1) from semitrailer.

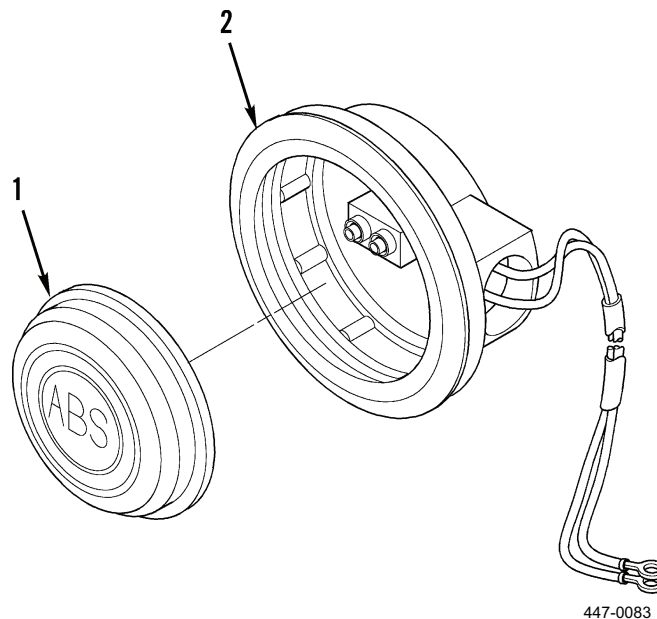

Figure 1. ABS Warning Light.

END OF TASK

INSTALLATION

1. Apply dielectric grease on pins and then connect connectors to back of ABS warning light (Figure 2, Item 1).
2. Install new grommet (Figure 2, Item 2) and ABS warning light (Figure 2, Item 1) at semitrailer bracket.

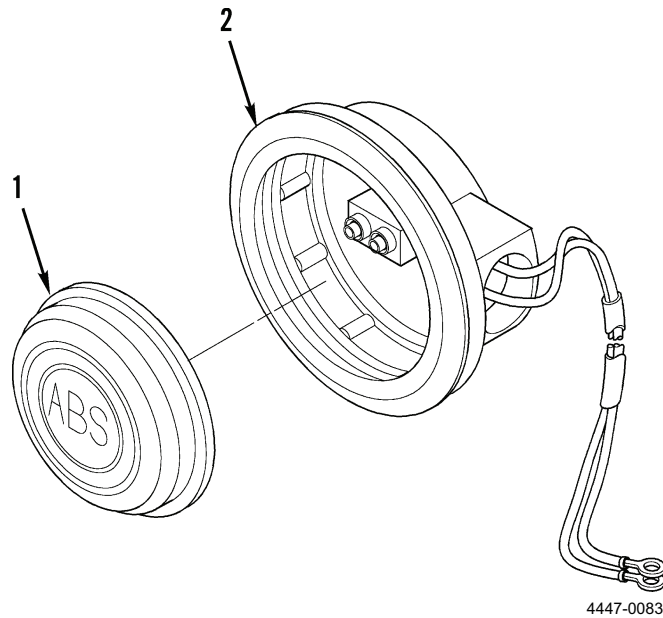

Figure 2. ABS Warning Light.

END OF TASK**FOLLOW-ON TASKS**

1. Connect semitrailer to prime mover.
2. Raise landing legs.
3. Remove/store chocks and ground boards.
4. Road test to ensure proper operation.

END OF TASK**END OF WORK PACKAGE**

ORGANIZATIONAL MAINTENANCE
HUBODOMETER® REPLACEMENT
Removal, Installation

INITIAL SETUP

Maintenance Level

Organizational

References

WP 0109

Tools and Special Tools

Tool kit, general mechanic's (Item 4, WP 0082)

Equipment Conditions

Landing legs down

Semitrailer disconnected from prime mover

Tires chocked

Ground boards emplaced

Materials/Parts

Nut assembly

CAUTION

Do not stand on HUBODOMETER®. Doing so could cause damage to equipment.

NOTE

- See WP 0109 for technical data.
- When ordering a new HUBODOMETER®, specify the mileage from the old HUBODOMETER®.

REMOVAL

Remove nut assembly (Figure 1, Item 2) and HUBODOMETER® (Figure 1, Item 1) from vehicular bracket (Figure 1, Item 3). Discard nut assembly.

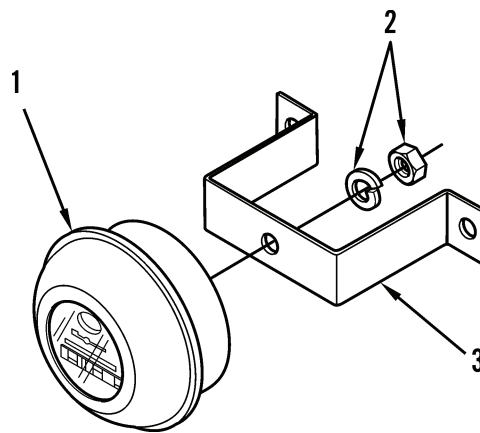

447-0084

Figure 1. HUBODOMETER®.

END OF TASK

INSTALLATION

Install HUBODOMETER® (Figure 2, Item 1) and new nut assembly (Figure 2, Item 2) on vehicular bracket (Figure 2, Item 3). Tighten nut assembly to 15 lb-ft (20 Nm).

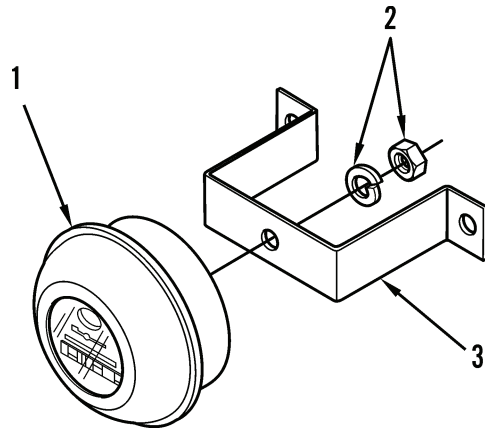

447-0084

Figure 2. HUBODOMETER®.

END OF TASK**FOLLOW-ON TASKS**

1. Connect semitrailer to prime mover.
2. Raise landing legs.
3. Remove/store chocks and ground boards.
4. Road test to ensure proper operation.

END OF TASK**END OF WORK PACKAGE**

ORGANIZATIONAL MAINTENANCE
CONSPICUITY TAPE REPLACEMENT
Removal, Installation

INITIAL SETUP
Maintenance Level

Organizational

Tools and Special Tools

Tool kit, general mechanic's (Item 4, WP 0082)

Materials/Parts

Tape, conspicuity (A/R)

Equipment Conditions

Landing legs down

Semitrailer disconnected from prime mover

Tires chocked

Ground boards emplaced

REMOVAL

Remove conspicuity tape (Figure 1 or 2, Item 1, 2, or 3) from semitrailer as necessary. Discard conspicuity tape.

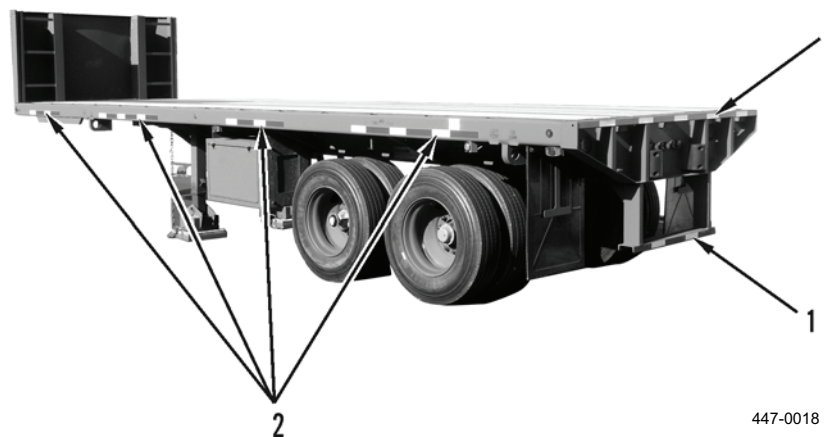

Figure 1. Conspicuity Tape (Sides and Rear).

END OF TASK**INSTALLATION****NOTE**

- Make sure surface area to be taped is clean and dry.
- There are two widths of rolled conspicuity tape. Be certain to apply appropriate conspicuity tape only to the locations indicated below.

1. Apply 2 in. (5.1 cm) red/white conspicuity tape (Figure 1, Item 2) to both sides of semitrailer as shown.
2. Apply 1-1/2 in. (3.8 cm) red/white conspicuity tape (Figure 1, Item 1) along full width of semitrailer rear.
3. Apply 1-1/2 in. (3.8 cm) red/white conspicuity tape (Figure 1, Item 1) along full width of rear bumper.

INSTALLATION - CONTINUED

4. Apply 2 in. (5.1 cm) white conspicuity tape (Figure 2, Item 3) to both sides of bulkhead as shown.

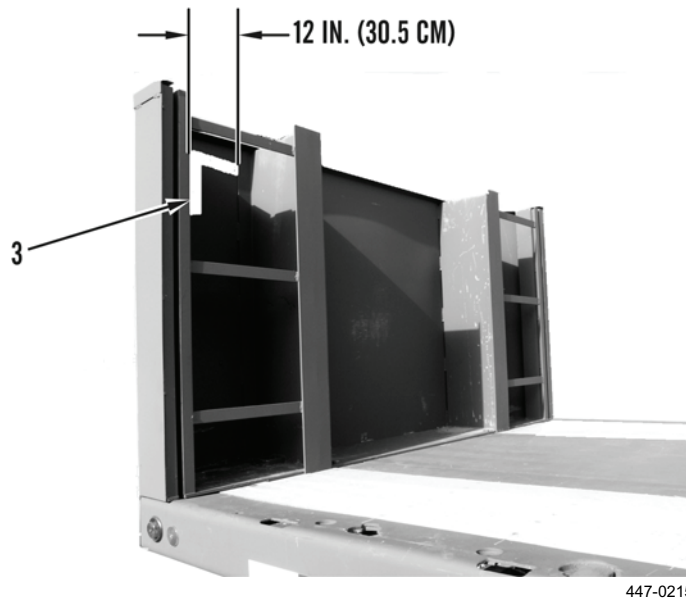

Figure 2. Conspicuity Tape (Bulkhead).

END OF TASK**FOLLOW-ON TASKS**

1. Connect semitrailer to prime mover.
2. Raise landing legs.
3. Remove/store chocks and ground boards.

END OF TASK**END OF WORK PACKAGE**

ORGANIZATIONAL MAINTENANCE
SERVICE UPON RECEIPT
General, Inspection Instructions, Servicing Instructions

INITIAL SETUP

Maintenance Level	References
Organizational	DA PAM 750-8
Tools and Special Tools	WP 0014
Tool kit, general mechanic's (Item 4, WP 0082)	WP 0016
	WP 0067
Materials/Parts	WP 0083
Cleaning compound, solvent, type III (Item 3, WP 0085)	
Rag, wiping (Item 13, WP 0085)	

GENERAL

When a new, used, or reconditioned semitrailer is first received, determine whether it has been properly prepared for service and is in condition to perform its mission. Follow the inspection instructions and servicing instructions specified in this work package.

INSPECTION INSTRUCTIONS

1. Read and follow all instructions on DD Form 1397 attached to conspicuous part of semitrailer.
2. Remove all straps, plywood, tape, seals, and wrappings.

WARNING

Solvent cleaning compound MIL-PRF-680 Type III is an environmentally compliant and low toxic material. However, it may be irritating to the eyes and skin. Use protective gloves and goggles. Use in well-ventilated areas. Keep away from open flames and other sources of ignition. Failure to follow this warning may cause injury or death to personnel.

3. Remove rust-preventive compound from coated exterior parts of semitrailer using solvent cleaning compound and rags.
4. Inspect semitrailer for damage incurred during shipment. Also check to see if equipment has been modified.
5. Check equipment against packing list to ensure that shipment is complete. Report any discrepancies in accordance with instructions in DA PAM 750-8.
6. Inventory BII (WP 0083).

END OF TASK

SERVICING INSTRUCTIONS

1. Perform all Operator/Organizational Preventive Maintenance Checks and Services (PMCS) (WP 0014 and WP 0016). Schedule next PMCS on DD Form 314.
2. Lubricate all lubrication points as described in WP 0067 regardless of interval.
3. Report any problems on DA Form 2407.
4. Perform a break-in road test of 25 miles (40 km) at a maximum speed of 50 mph (80 kph).

END OF TASK**END OF WORK PACKAGE**

ORGANIZATIONAL MAINTENANCE
PREPARATION FOR STORAGE OR SHIPMENT

INITIAL SETUP**Maintenance Level**

Organizational

Tools and Special Tools

Tool kit, general mechanic's (Item 4, WP 0082)

References

DA PAM 710

DA PAM 750-8

SB 740-98-1

References - Continued

TB 43-0209

TM 43-0139

TM 55-200

TM 55-601

TM 743-200-1

WP 0016

WP 0065

WP 0067

GENERAL

1. This work package contains requirements and procedures for administrative storage of equipment that is issued to and in use by Army activities worldwide.
2. The requirements specified herein are necessary to maintain equipment in administrative storage in such a way as to achieve the maximum readiness condition.
3. Equipment that is placed in administrative storage should be capable of being readied to perform its mission within a 24-hour period, or as otherwise may be prescribed by the approving authority. Before equipment is placed in administrative storage, current PMCS must be completed and deficiencies corrected.
4. Report equipment in administrative storage as prescribed for all reportable equipment.
5. Perform inspections, maintenance services, and lubrication as specified herein.
6. Records and reports to be maintained for equipment in administrative storage are those prescribed by DA PAM 750-8 for equipment in use.
7. A 10 percent variance is acceptable on time, running hours, or mileage used to determine the required maintenance actions.
8. Accomplishment of applicable PMCS, as mentioned throughout this work package, will be on a quarterly basis.

DEFINITION OF ADMINISTRATIVE STORAGE

The placement of equipment in administrative storage can be for short periods of time when a shortage of maintenance effort exists. Items should be ready for use within the time factors as determined by the directing authority. During the storage period, appropriate maintenance records will be kept.

PREPARATION OF EQUIPMENT FOR ADMINISTRATIVE STORAGE

Storage Site

1. Select the best available site for administrative storage. Separate stored equipment from equipment in use. Conspicuously mark the area "ADMINISTRATIVE STORAGE."
2. Covered space is preferred. When sufficient covered space for all items to be stored is not available, priority should be given to items which are most susceptible to deterioration from the elements. SB 740-98-1 should be used as a guide for establishing which items are most susceptible to deterioration.
3. Open sites should be improved hardstand, if possible. Unimproved sites should be firm, well-drained, and kept free of excessive vegetation.

Storage Plan

1. Store equipment so as to provide maximum protection from the elements and to provide access for inspection, maintenance, and exercising. Anticipate removal or deployment problems and take suitable precautions.
2. Take into account environmental conditions, such as extreme heat or cold, high humidity, blowing sand or loose debris, soft ground, mud, and heavy snow, and take adequate precautions.
3. Establish a fire plan and provide for adequate fire fighting equipment and personnel.

Maintenance Services and Inspection

1. Prior to storage, perform the next scheduled Organizational PMCS (WP 0016).
2. Inspect and approve the equipment prior to storage. Do not place equipment in storage in a nonmission capable condition.
3. Lubricate equipment in accordance with applicable lubrication instructions located in WP 0067.

END OF TASK

BII AND AAL ITEMS

1. Process BII and AAL items simultaneously with the major item to which they are assigned.
2. If possible, store BII and AAL items with the major item.
3. If stored apart from the major item, mark BII and AAL items with tags indicating the major item, its registration or serial number, and location, and store in protective-type closures. In addition, place a tag or list indicating the location of the removed items in a conspicuous place on the major item.

END OF TASK

CORRECTION OF SHORTCOMINGS AND DEFICIENCIES

Correct all shortcomings and deficiencies prior to storage, or obtain a waiver from the approving authority.

END OF TASK

GENERAL CLEANING, PAINTING, AND PRESERVATION

CAUTION

Do not direct water or steam, under pressure, against electrical wires or any exterior opening. Failure to follow this caution may result in damage to equipment.

1. Clean all equipment of dirt, grease, and other contaminants in accordance with applicable provisions of this manual. Do not use vapor degreasing. Remove foreign objects that are wedged in tire treads.

GENERAL CLEANING, PAINTING, AND PRESERVATION - CONTINUED

2. Remove rust and damaged paint by scraping, wire brushing, sanding, or buffing. Sand to a smooth finish and spot paint as necessary. Refer to TM 43-0139 and TB 43-0209.
3. After cleaning and drying, immediately coat unpainted wear surfaces with oil or grease, as appropriate (WP 0067).

NOTE

Air circulation under draped covers reduces deterioration from moisture and heat.

4. Place equipment and provide blocking or framing to allow ventilation and water drainage. Support cover away from item surfaces, which may rust, rot, or mildew.

END OF TASK**CARE OF EQUIPMENT IN ADMINISTRATIVE STORAGE****Maintenance Services**

After equipment has been placed in administrative storage, inspect, service, and exercise as specified in this manual. Refer to DA PAM 710.

Inspection

Inspection will usually be visual and must consist of at least a walk-around examination of all equipment to detect any deficiencies. Inspect equipment in open storage weekly and equipment in covered storage monthly. Inspect all equipment immediately after any severe storm or environmental change. The following are examples of things to look for during a visual inspection:

1. Low or flat tires.
2. Condition of preservatives, seals, and wraps.
3. Corrosion or other deterioration.
4. Missing or damaged parts.
5. Water in components.
6. Any other readily recognizable shortcomings or deficiencies.

Repair During Administrative Storage

Keep equipment in an optimum state of readiness. Accomplish the required services and repairs as expeditiously as possible. Whenever possible, perform all maintenance on-site.

CARE OF EQUIPMENT IN ADMINISTRATIVE STORAGE - CONTINUED

Exercising

Exercise equipment in accordance with Table 1 and the following instructions:

1. **Vehicle Major Exercise.** Depreserve equipment by removing only that material restricting exercise. Close all drains, remove blocks, and perform all before-operation checks. Couple semitrailer to towing vehicle, and drive for at least 25 miles (40 km). Make several right and left 90 degree turns. Make several hard braking stops without skidding. Do the following during exercising when it is convenient and safe: operate all other functional components and perform all during- and after-operation checks.
2. **Scheduled Services.** Scheduled services will include inspection per *Inspection* in this work package, and will be conducted in accordance with Table 1. Lubricate in accordance with instructions in WP 0067.
3. **Corrective Action.** Immediately take action to correct shortcomings and deficiencies noted. Record inspection and exercise results on DA Form 2404/DA Form 5988/E. Record and report all maintenance actions on DA Form 2407. After exercising, restore the preservation to the original condition.

Table 1: Exercise Schedule.

Weeks	2	4	6	8	10	12	14	16	18	20	22	24
PMCS						X						X
Scheduled Services		X		X		X		X		X		
Major Exercise												X

Rotation

To ensure utilization of all assigned materiel, rotate items in accordance with rotational plan that will keep equipment in operational condition and reduce maintenance efforts.

END OF TASK

PROCEDURES FOR COMMON COMPONENTS AND MISCELLANEOUS ITEMS

Tires

Visually inspect tires during each walk-around inspection. This inspection includes checking tires with a tire gage. Inflate, repair, or replace as necessary those found to be low, damaged, or excessively worn. Mark inflated and repaired tires with a crayon for checking at the next inspection.

Seals

Seals may develop leaks during storage, or shortly thereafter. If leaking persists, refer to the applicable maintenance section in this manual for corrective maintenance procedures.

END OF TASK

REMOVAL OF EQUIPMENT FROM ADMINISTRATIVE STORAGE

Activation

Restore the equipment to normal operating condition in accordance with the instructions contained in WP 0065.

Servicing

Resume the maintenance service schedule in effect at the commencement of storage, or service the equipment before the scheduled dates in order to produce a staggered maintenance workload.

END OF TASK

PREPARATION OF EQUIPMENT FOR SHIPMENT

Refer to TM 55-200, TM 55-601, and TM 743-200-1 for additional instructions on processing, storage, and shipment of materiel.

Semitrailers that have been removed from storage for shipment do not have to be reprocessed if they will reach their destination within the administrative storage period. Reprocess only if inspection reveals any corrosion, or if anticipated in-transit weather conditions make it necessary.

When a semitrailer is received that has already been processed for domestic shipment, as indicated on DD Form 1397, the semitrailer does not have to be reprocessed for storage unless corrosion and deterioration are found during the inspection upon receipt. List on SF 364 all discrepancies found because of poor preservation, packaging, packing, marking, handling, loading, storage, or excessive preservation. Repairs that cannot be handled by the receiving unit must have tags attached listing needed repairs. A report of these conditions will be submitted by the unit commander for action by an ordnance maintenance unit.

END OF TASK**END OF WORK PACKAGE**

ORGANIZATIONAL MAINTENANCE
LUBRICATION INSTRUCTIONS

GENERAL

This work package contains lubrication instructions, showing location, intervals, and proper materials for lubricating the semitrailer. These instructions are mandatory.

DETAILED LUBRICATION INFORMATION

1. Clean lubrication points, grease fittings, and surrounding areas before applying lubricant. Clean all lubrication points after lubricating to prevent accumulation of foreign matter. Clean and lubricate bearings as specified in TM 9-214.
2. Maintain a record of vehicle lubrication and report any discrepancies noted during lubrication. Refer to DA PAM 750-8 for maintenance forms and procedures to record and report any findings.

SPECIFIC LUBRICATION INSTRUCTIONS

1. Keep all lubricants in closed containers and store in a clean, dry place away from extreme heat. Keep container covers clean and do not allow dust, dirt, or other foreign material to mix with lubricants. Keep all lubrication equipment clean and ready for use.

WARNING

Wipe excess lubricant from area of brake shoe linings to prevent any contamination of linings. Replace linings that have been contaminated with lubricant. Failure to follow this warning may cause brakes to malfunction, resulting in serious injury or death to personnel.

NOTE

Grease streaks on the outside or inside of the wheel may indicate overpacking of the grease, an improperly installed grease seal, damage to the axle end, loose hardware, or gasket damage.

2. Keep all external parts of equipment not requiring lubrication clean of lubricants.
3. Refer to FM 9-207 for lubrication instructions in cold weather.
4. After operation in mud, sandy, or dusty conditions, or when mission allows, clean and inspect all points of lubrication for fouled lubricants. Change lubricants as required.

END OF TASK

LUBRICATION CHART AND DIAGRAMS

1. Refer to Table 1 for the lubrication chart. Intervals are based on normal operation. Adjust to compensate for abnormal and severe conditions or contaminated lubricants. During inactive periods, intervals may be extended commensurate with adequate preservation. Locations of lubrication points on semitrailer are shown in Figure 1.

WARNING

Solvent cleaning compound MIL-PRF-680 Type III is an environmentally compliant and low toxic material. However, it may be irritating to the eyes and skin. Use protective gloves and goggles. Use in well-ventilated areas. Keep away from open flames and other sources of ignition. Failure to do so may result in injury or death to personnel.

2. Before lubrication, clean fittings using cleaning compound. Dry before lubricating.
3. Re-lubricate after washing or fording as necessary.

Table 1. Lubrication Chart.

LUBRICATION POINTS	INTERVAL	LUBRICATION TYPE/ SPECIAL INSTRUCTIONS/ MAINTENANCE LEVEL ()
ABS Sensor Body and Spring Clip	When replaced or removed from clip	GAA, light coat on sensor body, wipe off excess. When removed from spring clip, clean off old grease and apply a new light coat. (O)
Automatic Slack Adjuster	Semiannually or every 6,000 miles (9,656 km) Semiannually or every 6,000 miles (9,656 km)	GAA, zerk fittings. (O) OE/HDO-10, hinge/latch, oil can points. (O)
Stowage Box and Padlocks	Monthly or every 1,000 miles (1,609 km)	OE/HDO-10, hinge/latch, oil can points. (C)
Twist Locks (8)	Monthly or every 1,000 miles (1,609 km)	Clean, oil can point OE/HDO-10 for housing. (C) GAA, zerk fittings. (O)
Tiedown Rings Cargo (36) Ammo (4) Lift/Tiedown (10)	Monthly or every 1,000 miles (1,609 km)	OE/HDO-10, oil can points. (C)
Landing Gear Shoes, Swing Pins, and Crank Handle	Monthly or every 1,000 miles (1,609 km)	OE/HDO-10, oil can points. (C)
All Receptacle Pins and Connectors	When taken apart/replaced	Dielectric grease. Clean and apply a thin coat. (O)
Kingpin and Bolster Plate	Monthly or every 1,000 miles (1,609 km)	GAA, clean, then apply thin coat on kingpin and bolster plate. (C) Make sure drain holes are not plugged.
Sling Eye Pockets (M871R and M871A1R)	Quarterly or every 3,000 miles (4,827 km)	GAA. (C)

LUBRICATION CHART AND DIAGRAMS - CONTINUED

Table 1. Lubrication Chart - Continued.

LUBRICATION POINTS	INTERVAL	LUBRICATION TYPE/ SPECIAL INSTRUCTIONS/ MAINTENANCE LEVEL ()
Sling Eye Locking Latches (M871R and M871A1R)	Monthly or every 1,000 miles (1,609 km)	GAA. (C)
Gladhand Springs and Bracket	Monthly or every 1,000 miles (1,609 km)	OE/HDO-10, oil can points. (C)
Wheel Bearings and Seals	Triennial or every 36,000 miles (57,935 km)	GAA, clean, inspect, and repack with clean GAA. (O) Replace seals. (O). Never reuse seals.
Brake Bushings, Rollers, Anchor Pins, S-Camshaft Lobes, Spider Face, Splines	Triennial or every 36,000 miles (57,935 km)	GAA, light coat, wipe off excess. (O)
S-Camshaft Support Bracket	Semiannually or every 6,000 miles (9,656 km)	GAA, zerk fittings. (O)
Spindles, Cam Follower Shaft, Journals	Triennial or every 36,000 miles (57,935 km)	GAA, light coat, wipe off excess. (O)

NOTE

Do not lubricate suspension system.

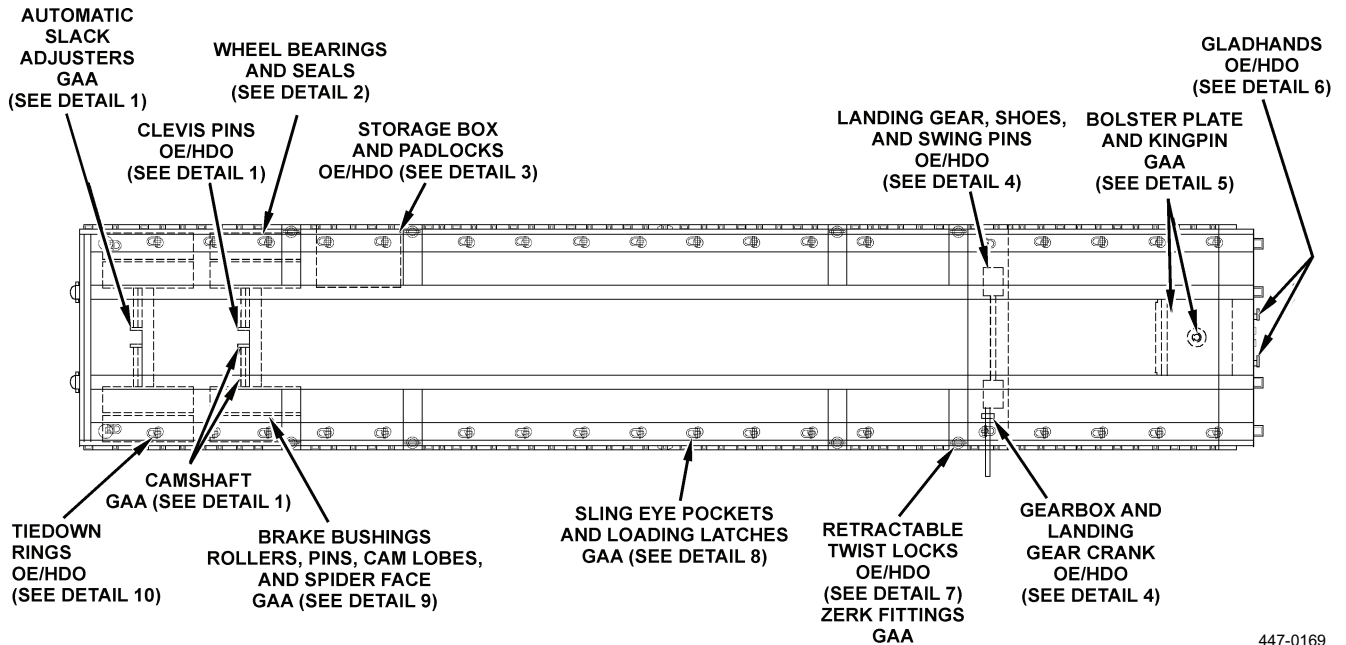

Figure 1. Lubrication Diagram.

447-0169

LUBRICATION CHART AND DIAGRAMS - CONTINUED

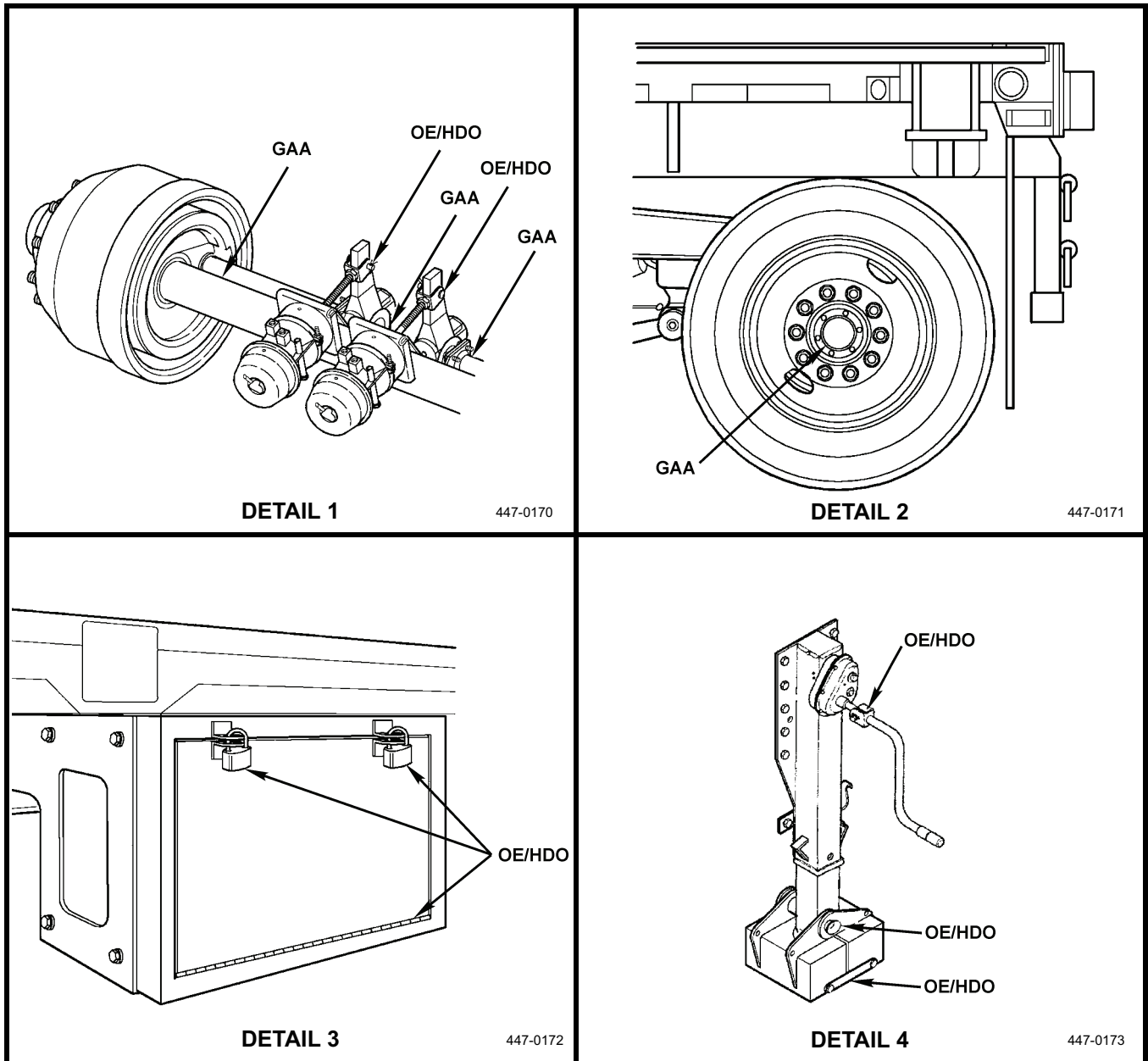

Figure 2. Lubrication Points.

LUBRICATION CHART AND DIAGRAMS - CONTINUED

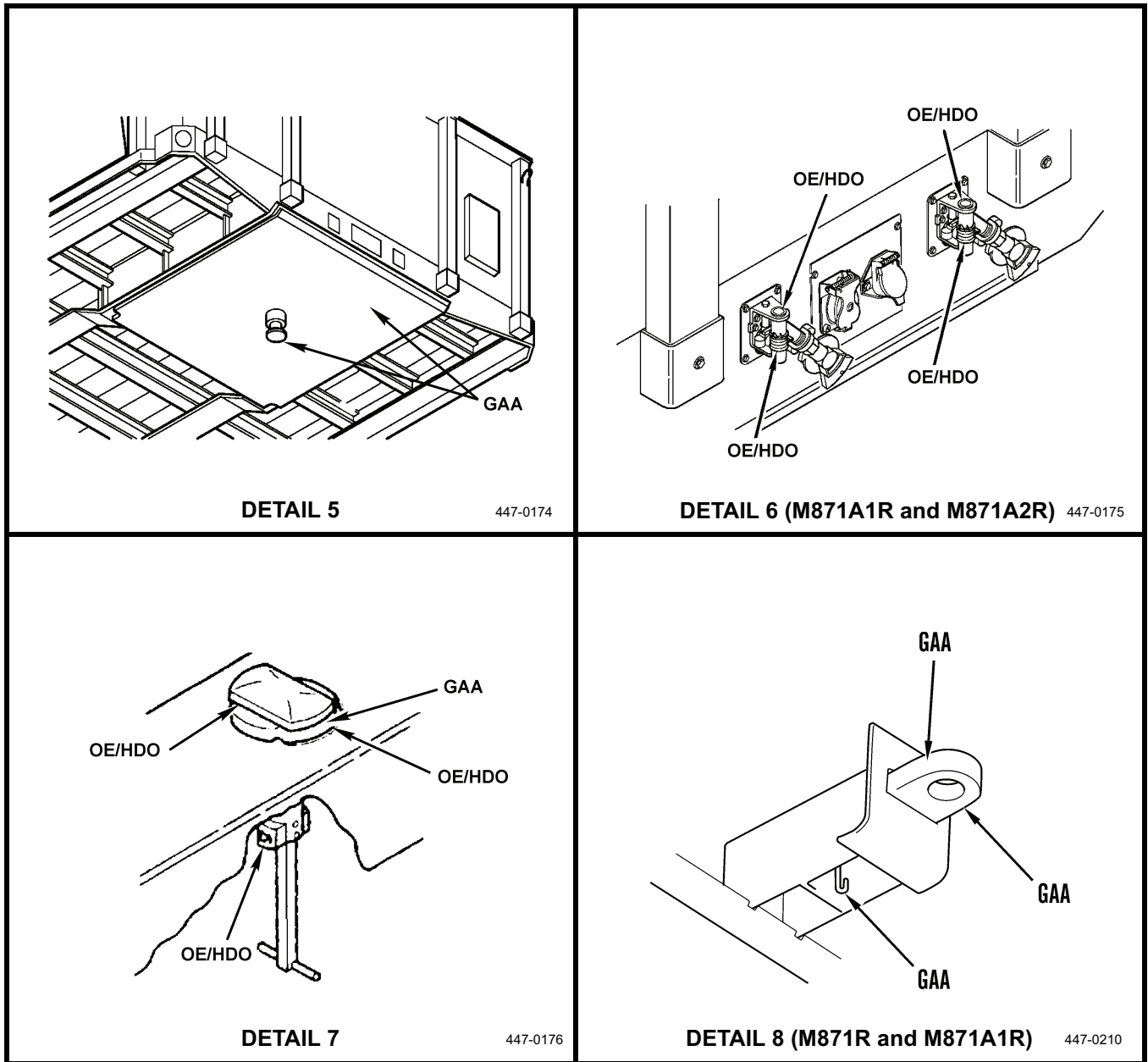

Figure 3. Lubrication Points.

LUBRICATION CHART AND DIAGRAMS - CONTINUED

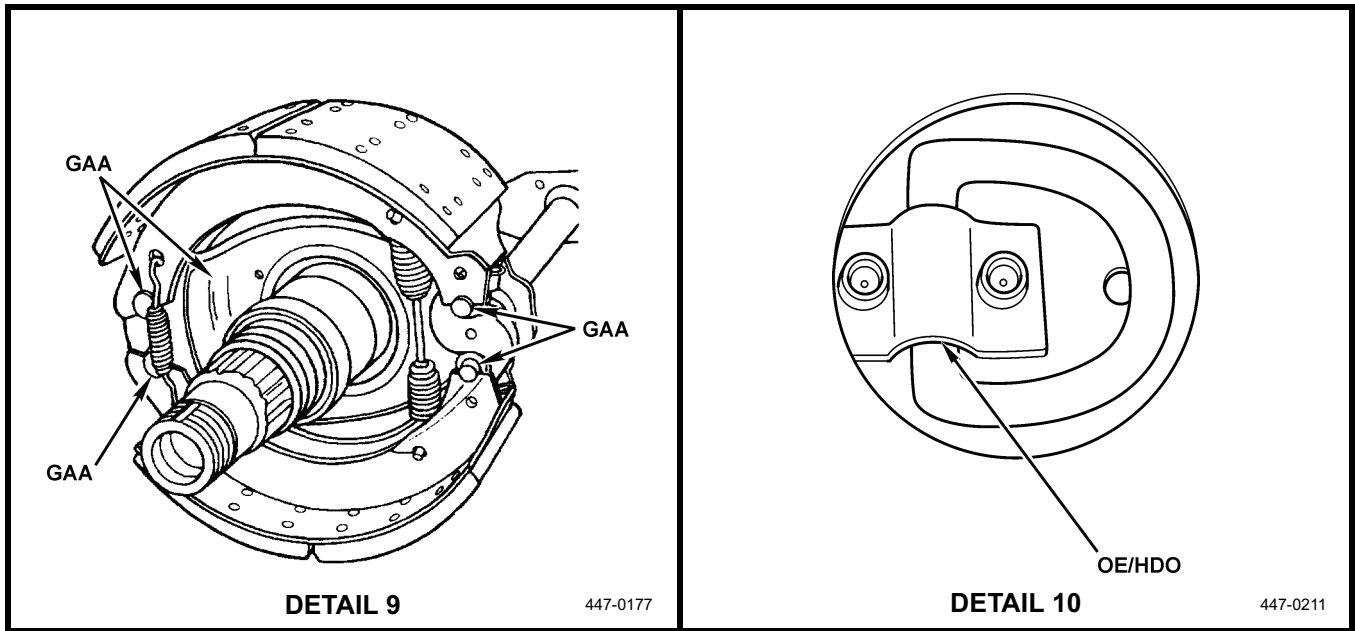

Figure 4. Lubrication Points.

END OF TASK

LUBRICANTS

Table 2 lists lubricants to be used in all temperature ranges.

Table 1. Lubricants Key.

LUBRICANTS	EXPECTED TEMPERATURES*		
	ABOVE +15°F (ABOVE -9°C)	+40°F to -15°F (+4° to -26°C)	+40°F to -65°F (+4°C to -54°C)
OE/HDO (MIL-PRF-2104) Lubricating Oil, Internal Combustion Engine, Tactical Service	OE/HDO-30	OE/HDO-30	
OEA (MIL-L-46167) Lubricating Oil, Internal Combustion Engine, Arctic			OEA
GAA (MIL-PRF-10924G) Grease, Automotive and Artillery	All Temperatures		
*For arctic operation, refer to FM 9-207.			

END OF TASK

COLD OPERATION

For operation of equipment in extended cold temperatures below -15°F (-26°C), remove lubricants prescribed in the key for temperatures above -15°F (-26°C). Re-lubricate with lubricants specified in the key for temperatures below -15°F (-26°C). If OEA lubricant is required to meet the temperature changes prescribed in the key, OEA lubricant is to be used in place of OE/HDO lubricant for all temperature ranges where OE/HDO lubricant is specified in the key.

END OF TASK**S-CAMSHAFT (SPECIFIC)**

1. When the wheels and hubs are removed, place a light film of lubricant on cam roller follower shafts, journals, and the top and bottom surface of the S-camshaft. Wipe off any excess lubricant.
2. Observe the following warning and caution when lubricating automatic slack adjusters.

WARNING

Do not use any grease with Teflon, over 3% molysulfide content, or “white” grease in the automatic slack adjusters. These lubricants will adversely affect the friction clutch and cause it not to hold the adjustment, resulting in premature failure, injury to personnel, and damage to equipment.

CAUTION

It is important not to overfill wheel-end cavity with lubricant. Do not exceed grease level indicated. Also, make sure excess grease is wiped away since it can contaminate brake linings and cause poor brake performance.

END OF TASK**BEARINGS/HUBS**

1. Pack bearing cones with grease by forcing grease into the cavities between rollers and cage from the large end of the cone. The use of a pressure packer is recommended; otherwise pack the bearings by hand.
2. Apply a light coat of grease to the spindle bearing journals and wipe off excess.
3. Fill the hub cavity with grease to the outer cap’s smallest diameter.
4. At the top of the spindle and as far back as possible, pump additional grease until it appears that the grease will run out. Install the outer bearing cone quickly.
5. Hub cavity will be filled approximately 1/3 full of grease (from the 4 to the 8 o’clock positions). This will involve installation of approximately 1-1/2 lb (0.7 kg) of grease.
6. Install the wheel retention hardware. Place a dab of grease across the face of the locknut for identification that hub cavity has been greased if caps are not to be immediately installed.

CAUTION

Brush a thin layer of GAA on the inside of the hub cap. Do not cover vent with grease. Do not pack the hub cap with grease. Do not coat the cap mounting flange with grease. Coating the cap vent will result in seepage of lubricant and may clog the vent. Failure to comply can cause damage to equipment.

7. When brake shoes are replaced, apply an even coat of lubricant between contact face of anchor pin bushing, brake shoe area, and spider faces. Coat anchor pin completely. Wipe off all excess grease.

END OF TASK

SUSPENSION

Hutchens suspension does not require lubrication, but new replacement suspension hardware (nuts/threads) should be oiled before assembly and a wet torque applied. In-service torque values should have dry torque values applied.

END OF TASK**GENERAL SEMITRAILER LUBRICATION REQUIREMENTS****NOTE**

High-pressure or steam wash is not authorized for the semitrailer.

1. The oil requirements for the semitrailer consist of only two types of lubricant, OEA and OE/HDO, for oil can points. Variants of the lubricating oil are authorized only due to temperature variations.
2. The grease requirements for the semitrailer consists of only GAA. Current GAA stocks are 100% synthetic and allow for extended service intervals as long as seals and gaskets are not leaking grease.
3. All fittings and lubrication points should be wiped clean prior to being lubed.
4. If a padlock is used, make sure it is lubricated and operational.
5. Reference TM 43-0139 for semitrailer painting and TB 43-0209 for stencil identification marking.

END OF TASK**FORDING OPERATIONS**

1. Use common sense. If the mission/situation does not allow for after-fording inspection, inspect the semitrailer when the mission allows.
2. Snub the brakes three or four times to dry them out after fording.
3. If hubs were hot prior to fording there is a good chance water may have been sucked in through the hub cap. If cold or warm to touch they should be all right.
4. If hubs and seals showed any signs of leakage prior to fording they may be contaminated by water after fording semitrailer.
5. When mission allows, carefully remove hub caps to inspect for water contamination. If gasket is damaged, it must be replaced.
6. Use low-pressure fresh water to flush out all salt contamination, including road salt, from semitrailer to prevent corrosion.

END OF TASK**END OF WORK PACKAGE**

ORGANIZATIONAL MAINTENANCE
TORQUE LIMITS

SCOPE

This work package lists standard torque values and provides general information for applying torque. Special torque values and tightening sequences are indicated in the maintenance procedures for applicable components.

GENERAL

1. Always use torque values listed in Tables 2 and 3 when a maintenance procedure does not give a specific torque value.
 - a. Table 2 provides torque limits for SAE standard fasteners.
 - b. Table 3 provides torque limits for metric fasteners.
2. Unless otherwise indicated, standard torque tolerance shall be $\pm 10\%$.
3. Torque values listed are based on clean, dry threads. Reduce torque by 10% when engine oil is used as a lubricant. Reduce torque by 20% if new plated capscrews are used.

CAUTION

If replacement capscrews are of higher grade than originally supplied, use torque specifications for the original. This will prevent equipment damage due to overtightening.

TIGHTENING METAL FASTENERS

When torquing a fastener, select a wrench whose range fits the required torque value. A torque wrench is most accurate from 25 to 75% of its stated range. A wrench with a stated range of 0 to 100 lb-ft (0 to 136 Nm) will be most accurate from 25 to 75 lb-ft (34 to 102 Nm). The accuracy of readings will decrease as you approach 0 lb-ft or 100 lb-ft (136 Nm). The following ranges are based on this principle.

Table 1. Metal Fasteners.

STATED RANGE		MOST EFFECTIVE RANGE	
0 to 200 lb-in.	(0 to 23 Nm)	50 to 150 lb-in.	(6 to 17 Nm)
0 to 600 lb-ft	(0 to 813 Nm)	50 to 150 lb to ft	(68 to 610 Nm)
0 to 170 lb-ft	(0 to 230 Nm)	44 to 131 lb-ft	(60 to 178 Nm)
15 to 75 lb-ft	(20 to 102 Nm)	30 to 60 lb-ft	(41 to 81 Nm)

TIGHTENING METAL FASTENERS - CONTINUED

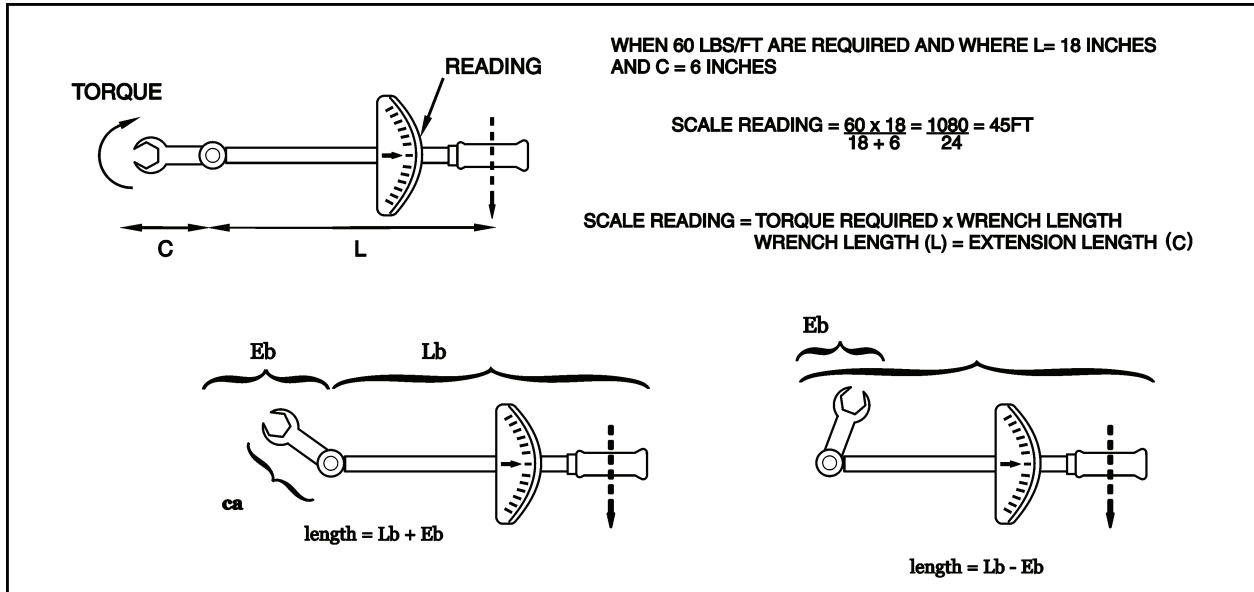

447-0269

Figure 1. Torque Wrench Formula.

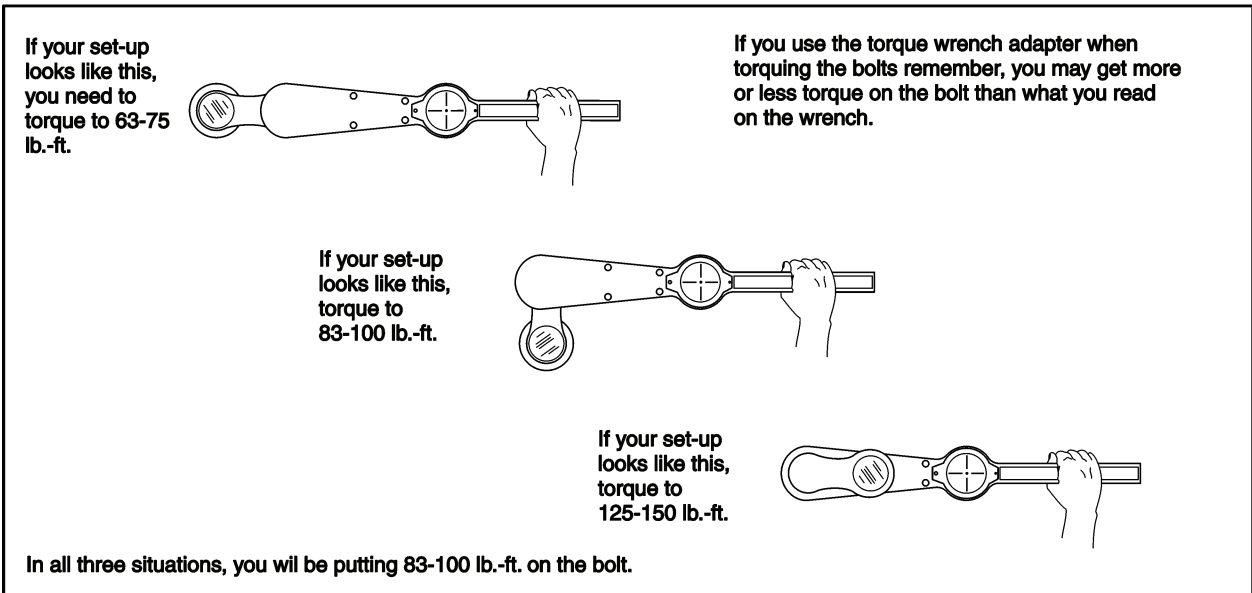

447-0270

Figure 2. Torque Wrench Adapter Setups.





END OF TASK

INSTALLATION AND TORQUING

1. **Matching Nuts.** Matching nuts require a minimum height equal to the basic diameter of the bolt. The same is true of tapped holes. In tapped softer materials, the depth of the tapped hole should be 1-1/2 times the basic diameter of the bolt.
2. **Threaded Protrusion.** In all installations, bolts, studs, and screws must extend through the nut at least a length equivalent to two complete threads. This applies to both self-locking and plain nuts.
3. **Torquing Self-Locking Nuts.** To obtain the correct recommended torque value on self-locking nuts, the nut must be tightened until it is one turn from the beginning of seating. At this point, if the torque is less than 1/3 of the recommended torque, it should be disregarded and the nut tightened to the recommended torque value. If the torque is 1/3 or more of the recommended torque, it should be added to the recommended torque. Example: The recommended torque is 50 to 70 lb-in. (6 to 8 Nm). The torque at one turn from seating is 30 lb-in. (3 Nm). The correct torque wrench reading would be 80 to 100 lb-in. (9 to 11 Nm).
4. **Retorquing Fasteners.** Procedures intended for installing metal fasteners can cause incorrect reading when used to check or retorque already installed fasteners during maintenance. Before checking or retorquing an already installed threaded fastener, first mark the fastener and its companion components so the marks are in line. Second, back it off a 1/4 turn to loosen it. Torque it to the specification with an even steady pull on the torque wrench. The marks should be in line; if not, the marks will indicate the fastener was under- or over-torqued.
5. **Standard Torque Charts.** Standard torque charts have been established for dry and wet torque conditions. Surface variations such as thread roughness, scale paint, lubrication (oil, grease, etc.), hardening, and plating may alter these values considerably. Tables 2 and 3 are standard torque charts.
6. To find the grade of the screw that is to be installed, match the markings on the head to the correct picture of CAPSCREW HEAD MARKINGS on tables 2 and 3. Manufacturer's marks may vary.

INSTALLATION AND TORQUING - CONTINUED

Table 2. Torque Limits - SAE Standard Fasteners.

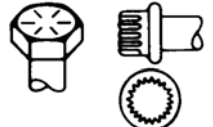
QUALITY OF MATERIAL	INDETERMINATE	MINIMUM COMMERCIAL	MEDIUM COMMERCIAL	BEST COMMERCIAL
SAE Grade Number	1 or 2	5	6 or 7	8
Capscrew Head Markings	 			
Manufacturer's marks may vary				
These are all SAE Grade 5 (3 line)				
CAPSCREW BODY SIZE IN. - THREAD	TORQUE LB-FT (NM)	TORQUE LB-FT (NM)	TORQUE LB-FT (NM)	TORQUE LB-FT (NM)
1/4 20 28	5 (7) 6 (8)	8 (11) 10 (14)	10 (14)	12 (16) 14 (19)
5/16 18 24	11 (15) 13 (18)	17 (23) 19 (26)	19 (26)	24 (33) 27 (37)
3/8 16 24	18 (24) 20 (27)	31 (42) 35 (47)	34 (46)	44 (60) 49 (66)
7/16 14 20	28 (38) 30 (41)	49 (66) 55 (75)	55 (75)	70 (95) 78 (106)
1/2 13 20	39 (53) 41 (56)	75 (102) 85 (115)	85 (115)	105 (142) 120 (163)
9/16 12 18	51 (69) 55 (75)	110 (149) 120 (163)	120 (163)	155 (210) 170 (231)
5/8 11 18	83 (113) 95 (129)	150 (203) 170 (231)	167 (226)	210 (285) 240 (325)
3/4 10 16	105 (142) 115 (156)	270 (366) 295 (400)	280 (380)	375 (508) 420 (569)
7/8 9 14	160 (217) 175 (237)	395 (536) 435 (590)	440 (597)	605 (820) 675 (915)
1 8 14	235 (319) 250 (339)	590 (800) 660 (895)	660 (895)	910 (1,234) 990 (1,342)

INSTALLATION AND TORQUING - CONTINUED

Table 3. Torque Limits - Metric Fasteners.

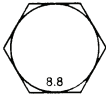
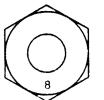
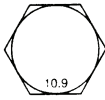
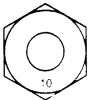
THREAD DIAMETER-PITCH				
	CLASS 8.8 BOLT	CLASS 8 NUT	CLASS 10.9 BOLT	CLASS 10 NUT
	Torque: lb-ft (Nm)		Torque: lb-ft (Nm)	
M6	5 (7)		7 (9)	
M8	12 (16)		17 (23)	
M8 x 1	13 (18)		18 (24)	
M10	24 (33)		34 (46)	
M10 x 1.25	27 (37)		38 (52)	
M12	42 (57)		60 (81)	
M12 x 1.5	43 (58)		62 (84)	
M14	66 (89)		95 (129)	
M14 x 1.5	72 (98)		103 (140)	
M16	103 (140)		148 (201)	
M16 x 1.5	110 (149)		157 (213)	
M18	147 (199)		203 (275)	
M18 x 1.5	165 (224)		229 (310)	
M20	208 (282)		288 (390)	
M20 x 1.5	213 (313)		320 (434)	
M22	283 (384)		392 (531)	
M22 x 1.5	315 (427)		431 (584)	
M24	360 (488)		498 (675)	
M24 x 2	392 (531)		542 (735)	
M27	527 (715)		729 (988)	
M27 x 2	569 (771)		788 (1,068)	
M30	715 (969)		990 (1,342)	
M30 x 2	792 (1,074)		1,096 (1,486)	

* All plated and unplated fasteners should be coated with oil before installation.

† Use these torque values if either the bolt or nut is lubricated or plated (zinc-phosphate conversion-coated, cadmium-plated, or waxed).

END OF TASK

END OF WORK PACKAGE

CHAPTER 9
DIRECT SUPPORT AND GENERAL SUPPORT MAINTENANCE

DIRECT SUPPORT AND GENERAL SUPPORT MAINTENANCE
DIRECT SUPPORT AND GENERAL SUPPORT MAINTENANCE INSTRUCTIONS
**General, Work Safety, Cleaning Instructions,
Inspection Instructions, Repair Instructions, Tagging Wires and Hoses,
Corrosion Protection**

INITIAL SETUP
Maintenance Level

Direct Support/General Support

Tools and Special Tools

Tool kit, general mechanic's (Item 4, WP 0082)

Materials/Parts

Brush, scrub (Item 2, WP 0085)

Cleaning compound, solvent, type III
(Item 3, WP 0085)

Cloth, abrasive (Item 4, WP 0085)

Detergent, general purpose, liquid
(Item 5, WP 0085)

Linseed oil (Item 9, WP 0085)

Materials/Parts - Continued

Rag, wiping (Item 13, WP 0085)

Rust inhibitor (Item 14, WP 0085)

Tag, marker (Item 16, WP 0085)

UV wood protector (Item 18, WP 0085)

References

TB 9-2510-242-40

TM 9-214

TM 9-247

WP 0067

WARNING

For service and repair tasks on the semitrailer, the ground boards and tire chocks should be used to ensure safe coupling and prevent semitrailer movement. Failure to comply could cause injury to personnel and damage to equipment.

GENERAL

1. This work package contains general shop practices and specific methods you must be familiar with to properly maintain your semitrailer. You should read and understand these practices and methods before performing any maintenance tasks.
2. Before beginning a task, find out how much repair, modification, or replacement is needed to fix the equipment. Sometimes the reason for equipment failure can be seen right away, and complete teardown is not necessary. Disassemble equipment only as far as necessary to repair or replace damaged or broken parts.
3. Resources are not listed in the initial setup unless they apply to the procedure.
4. All tags and forms attached to equipment must be checked to learn the reason for equipment's removal from service. Modification Work Orders (MWOs) and Technical Bulletins (TBs) must also be checked for equipment changes and updates.
5. In some cases, a part may be damaged by removal. If the part appears to be good, and other parts behind it are not defective, leave it on and continue with the procedure. Here are a few simple rules:
 - a. Do not remove dowel pins or studs unless loose, bent, broken, or otherwise damaged.
 - b. Do not remove bearings or bushings unless damaged. If you need to remove them to access parts behind, pull bearings and bushings out carefully.
 - c. Replace all gaskets, seals, lockwashers, cotter pins, and other locking hardware.
 - d. Ensure all parts are lubricated as specified in WP 0067.

WORK SAFETY

1. Observe all WARNINGS and CAUTIONS. Always use power tools carefully.
2. Protect yourself against injury. Wear protective gear such as safety goggles or faceshield, safety shoes, rubber apron, and gloves.
3. When lifting heavy parts, have someone help you. Ensure that lifting/stabilizing equipment is working properly, is suitable for the assigned task, and is secure against slipping.
4. All maintenance should be performed with:
 - a. Semitrailer parking brake engaged.
 - b. Prime mover in neutral with parking brake engaged, if attached.
 - c. Prime mover engine stopped, if attached.
 - d. Front and rear of tires chocked.
 - e. Ground boards emplaced.

END OF TASK**CLEANING INSTRUCTIONS****WARNING**

Improper cleaning methods and use of unauthorized cleaning liquids or solvents can injure personnel and damage equipment.

CAUTION

Do not use high-pressure water or steam to clean semitrailer. Use only low-pressure water and bristled brushes. Be especially careful when cleaning electrical system components to include lighting. Damage or impaired operation will result if this caution is not observed.

General

Cleaning instructions will be the same for a majority of parts and components that make up the semitrailer. The following should apply to all cleaning operations:

1. Clean all parts before inspection, after repair, and before assembly.
2. Keep hands free of grease which can collect dust, dirt, and grit.
3. After cleaning, all parts should be covered or wrapped to protect them from dust and dirt. Parts that are subject to rust should be lightly oiled.

Castings, Forgings, and Machined Metal Parts**WARNING**

Solvent cleaning compound MIL-PRF-680 Type III is an environmentally compliant and low toxic material. However, it may be irritating to the eyes and skin. Use protective gloves and goggles. Use in well-ventilated areas. Keep away from open flames and other sources of ignition. Failure to do so may result in injury or death to personnel.

1. Clean inner and outer surfaces with solvent cleaning compound.
2. Remove grease and accumulated deposits with a stiff bristle brush.

CLEANING INSTRUCTIONS - CONTINUED**WARNING**

Particles blown by compressed air are hazardous. DO NOT exceed 15 psi (103 kPa) nozzle pressure when drying parts with compressed air. Use a maximum of 30 psi (207 kPa) when cleaning components. DO NOT direct compressed air against human skin. To prevent injury, user must wear protective goggles or face shield. Make sure air stream is directed away from used for clearing restrictions should never exceed 30 psi (207 kPa). Wear protective clothing (goggles/shield, gloves, etc.) and use caution to avoid injury to personnel.

3. Clear all threaded holes with compressed air to remove dirt and cleaning fluids.

Grease Seals, Electrical Cables, and Flexible Hoses**CAUTION**

Do not wash grease seals, electrical harnesses, and flexible hoses with solvent cleaning compound or mineral spirits. Serious damage or destruction of material would result.

Wash electrical cables and flexible hoses with a solution of detergent and water and wipe dry.

Bearings

Clean bearings in accordance with TM 9-214.

END OF TASK**INSPECTION INSTRUCTIONS****NOTE**

All damaged areas should be marked for repair or replacement.

1. All components and parts must be carefully checked to determine if they are serviceable for use, can be repaired, or must be scrapped.
2. Inspect drilled and tapped (threaded) holes for the following:
 - a. Wear, distortion, cracks, and any other damage in or around holes.
 - b. Threaded areas for wear, distortion (stretching), and evidence of cross-threading.
3. Inspect metal lines, flexible lines (hoses), and metal fittings for the following:
 - a. Metal lines for sharp kinks, cracks, bad bends, and dents.
 - b. Flexible lines for fraying, evidence of leakage, and loose metal fittings or connectors.
 - c. Metal fittings and connectors for thread damage and worn or rounded hex heads.
4. Inspect castings, forgings, and machined metal parts for the following:
 - a. Machined surfaces for nicks, burrs, raised metal, wear, and other damage.
 - b. Inner and outer surfaces for breaks and cracks.
5. Inspect bearings in accordance with TM 9-214.

END OF TASK

REPAIR INSTRUCTIONS

1. Any repair procedure peculiar to a specific part or component is covered in the section relating to that item. After repair, clean all parts thoroughly to prevent dirt, metal chips, or other foreign material from entering any working parts.
2. Repair casting, forgings, and machined metal parts using the following instructions:
 - a. Repair minor cracked casting or forgings in accordance with TB 9-2510-242-40.

WARNING

Solvent cleaning compound MIL-PRF-680 Type III is an environmentally compliant and low toxic material. However, it may be irritating to the eyes and skin. Use protective gloves and goggles. Use in well-ventilated areas. Keep away from open flames and other sources of ignition. Failure to do so may result in injury or death to personnel.

- b. Repair minor damage to machined surfaces with a fine mill file or an abrasive cloth dipped in cleaning compound.
 - c. Replace any deeply nicked machined surface that could affect the assembly operation.
 - d. Repair minor damage to threaded capscrew holes with thread tap of same size to prevent cutting oversize.
3. After repair, clean all parts thoroughly to prevent dirt, metal chips, or other foreign material from entering any working parts.

END OF TASK

TAGGING WIRES AND HOSES

1. As soon as the first wire, hose, or tube is disconnected, write number "1" on two tags. Secure one tag to the wire, hose, or tube and the other tag to the terminal, nipple, or fitting. After disconnecting the second wire, hose, or tube, write number "2" on two tags. Secure one tag to the wire, hose, or tube, and the second tag to the terminal, nipple, or fitting. Do the same for all wires, hoses, and tubes.
2. Note which numbers you used, in pencil, on the illustrations in this manual. This will help you to accurately re-tag, if tags are removed to perform cleaning and maintenance work.
3. Remove all tags when finished.

END OF TASK

CORROSION PROTECTION

General Instructions

1. To ensure a long operational life for the semitrailer, the following is presented to assist maintenance personnel. This is not meant to supersede or replace current support operations or authorized publications.
2. Worldwide operations present many environmental impacts on the semitrailer from salt water to ice/snow melt chemicals. Areas of conflict have their own ways of ventilating and damaging the semitrailer. All these impacts add up to shortened operational life.

Tips

Keep the semitrailer clean, which will allow for more complete inspection of welds and components. Use low-pressure water, detergent, and brushes for cleaning.

- a. Flush out undercarriages, suspensions, and wheel ends with clean low-pressure water if operating in a salt environment, especially fording, as soon as the mission allows.
- b. Keep debris out of wheel ends and twistlock pockets.

CORROSION PROTECTION - CONTINUED

- c. Annually clean deck wood and roll/spray on boiled linseed oil or a good commercial UV wood protectorate. Apply to top areas of deck wood.
- d. Protect all exterior areas from rust — clean off rust, prime metal, and paint area.
- e. Application of 10-wt. oil at oil can points as specified by WP 0067 will help protect components and ensure they will work when needed.
- f. Keep bolster plate drain holes free of grease and debris so they drain/air out freely.

Corrosion Protection

If paint has worn off or damage/repair has taken it off the undercarriage, frame, fillets, gussets, or any other protected area, re-coat with rust inhibitor and CARC paint.

Kingpin and Bolster Plate

If the kingpin is replaced, inspect the interior structure for rust. Clean and protect the interior with rust inhibitor; do not plug up bolster plate drain holes. Make sure all welds are protected inside and out. Inspect the kingpin and bolster plate in accordance with PMCS requirements.

Protection Scheduling

1. It is a good idea to periodically take a look at the undercarriage, especially after off-road operations. The following is suggested:
 - Monthly: Visually inspect the undercarriage for rust and damage. Touch up paint as required.
2. If operating in a salt or road chemical environment, you should inspect/protect these areas as soon as possible and wash these areas with clean water as soon as possible after operation.

END OF TASK**END OF WORK PACKAGE**

DIRECT SUPPORT AND GENERAL SUPPORT MAINTENANCE**STOWAGE BOX SIDE PANELS REPLACEMENT****Removal, Installation**

INITIAL SETUP**Maintenance Level**

Direct Support

Personnel Required

Two

Tools and Special Tools

Tool kit, general mechanic's (Item 4, WP 0082)

Hydraulic floor jack

Suitable lifting device, 300-lb capacity

References

TM 9-247

WP 0057

Materials/PartsCleaning compound, solvent, type III
(Item 3, WP 0085)

Cloth, abrasive (Item 4, WP 0085)

Oil, lubricating (Item 11, WP 0085)

Rag, wiping (Item 13, WP 0085)

Locknut (4)

Equipment Conditions

Landing legs down

Semitrailer disconnected from prime mover

Ground boards emplaced

Tires chocked

BII removed from stowage box

WARNING

Stowage box weighs 195 lb (88 kg). Use suitable lifting device and two personnel to replace stowage box. Failure to comply may result in injury or death to personnel.

REMOVAL

Remove stowage box (Figure 1, Item 4) from semitrailer frame (WP 0057). Grind off old welds and prepare surface for welding of side panel brackets (Figure 1, Item 5) to frame and rail.

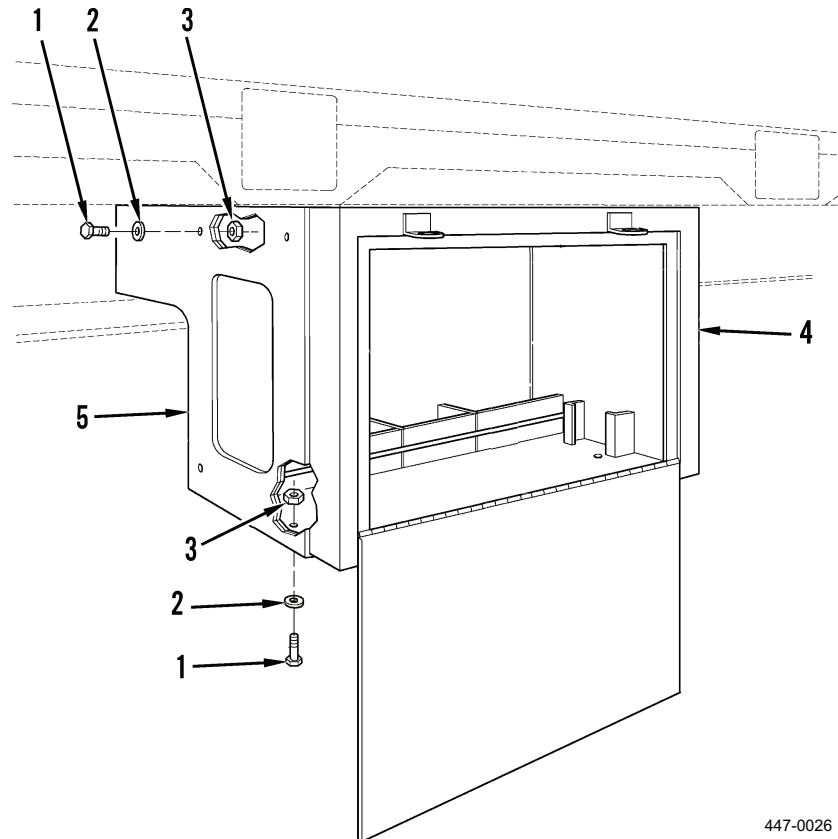

Figure 1. Stowage Box Side Panel.

END OF TASK**INSTALLATION**

1. Ensure all bare metal is painted.
2. Insert bolt (Figure 1, Item 1) with washer (Figure 1, Item 2) through side panel (Figure 1, Item 5) mounting hole and stowage box (Figure 1, Item 4). Place another washer on bolt inside stowage box and tighten bolt down with locknut (Figure 1, Item 3); repeat for other three mounting locations.
3. Position side panel brackets (Figure 1, Item 5), with stowage box (Figure 1, Item 4) installed, in place at frame (beam) and rail.
4. Tack weld both side panel brackets (Figure 1, Item 5) in place at frame (beam) and rail.
5. Remove locknuts (Figure 1, Item 3), washers (Figure 1, Item 2), bolts (Figure 1, Item 1), and stowage box (Figure 1, Item 4), leaving side panels (Figure 1, Item 5) tack-welded in place at frame (beam) and rail. Discard locknuts.
6. Use a continuous weld on each side panel bracket (Figure 1, Item 5) to weld brackets solidly to frame (beam) and rail.
7. Insert bolt (Figure 1, Item 1) with washer (Figure 1, Item 2) through side panel (Figure 1, Item 5) mounting hole and stowage box (Figure 1, Item 4). Place another washer on bolt inside stowage box and tighten bolt down with new locknut (Figure 1, Item 3); repeat for other three mounting locations.
8. Lubricate padlocks and hinges to ensure smooth, rust-free operation. Periodically lubricate padlocks and hinges to maintain serviceability.

END OF TASK

FOLLOW-ON TASKS

1. Secure BII in stowage box.
2. Connect semitrailer to prime mover.
3. Raise landing legs.
4. Remove/store chocks and ground boards.

END OF TASK**END OF WORK PACKAGE**

DIRECT SUPPORT AND GENERAL SUPPORT MAINTENANCE
SUSPENSION REPLACEMENT (M871R AND M871A1R)
Removal, Installation

INITIAL SETUP
Maintenance Level

Direct Support

Personnel Required

Four

Tools and Special Tools

Tool kit, general mechanic's (Item 4, WP 0082)
 Shop equipment, automotive maintenance and
 repair (Item 3, WP 0082)
 Floor jack
 Jack stands

References

WP 0111

Equipment Conditions

Landing legs down
 Semitrailer disconnected from prime mover
 Rear of semitrailer supported by jack stands
 Tires and wheels removed (WP 0021)
 Hubs and brake drums removed (WP 0033)

Materials/Parts

Locknut (32)

WARNING

- Jack must be positioned directly under axle to prevent slippage. Direct all personnel to stay clear of semitrailer when supported in the air. Failure to comply could result in injury or death to personnel or damage to equipment.
- To prevent shifting of semitrailer, floor jack should be used only on a hard, level surface. Use ground boards, if necessary. Check tires. Failure to comply could result in injury or death to personnel.

REMOVAL

1. Remove eight bolts (Figure 1, Item 1), washers (Figure 1, Item 24), and locknuts (Figure 1, Item 23) from trunnion center support. Discard locknuts.
2. Remove four hex bolts (Figure 1, Item 2) and hex nuts (Figure 1, Item 6) from two bottom brackets of trunnion center support.

WARNING

The trunnion must be firmly supported with jack stands or floor jacks prior to performing steps 3 and 4. Failure to comply could result in injury to personnel and damage to equipment.

3. Remove four hex nuts (Figure 1, Item 22), washers (Figure 1, Item 21), and top plate (Figure 1, Item 9) from two trunnion U-bolts (Figure 1, Item 10) and separate lower trunnion hub (Figure 1, Item 20) from upper trunnion hub (Figure 1, Item 18).
4. Repeat step 3 on opposite side of semitrailer.

WARNING

The trunnion tube weighs 100 lb (45.4 kg) and requires two persons to lift. Failure to comply could result in injury to personnel.

5. Remove two washers (Figure 1, Item 3) and bushings (Figure 1, Item 19) from both sides of trunnion tube (Figure 1, Item 4) and remove trunnion tube from suspension.

WARNING

The axles must be firmly supported with jack stands or floor jacks prior to performing steps 6 thru 10. Failure to comply may result in injury to personnel.

6. Remove eight hex nuts (Figure 1, Item 6) and 16 washers (Figure 1, Item 5) from four U-bolts (Figure 1, Item 17) and remove U-bolts from two spring cap ends (Figure 1, Item 12).
7. Repeat step 6 on opposite side of semitrailer.

WARNING

Axles weighs 200 lb (90.7 kg) and require four persons to lift. Failure to comply could result in injury to personnel.

8. Remove eight bolts (Figure 1, Item 7), washers (Figure 1, Item 15), and locknuts (Figure 1, Item 16) from two spring cap ends (Figure 1, Item 12). Discard locknuts.
9. Remove two spring seats (Figure 1, Item 14), adjustment plates (Figure 1, Item 13), and four rubber pads (Figure 1, Item 11) from spring (Figure 1, Item 8).
10. Repeat steps 8 and 9 on opposite side of semitrailer.

REMOVAL - CONTINUED

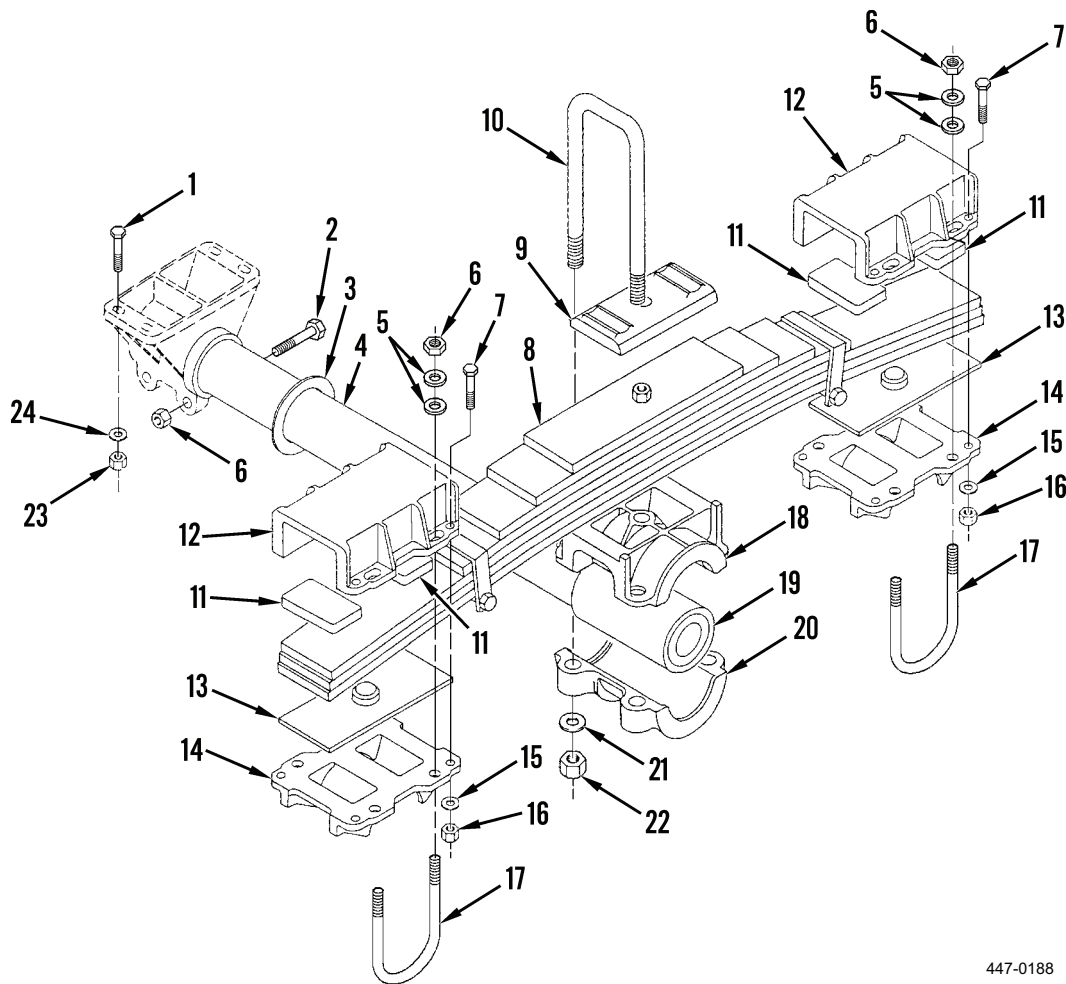

447-0188

Figure 1. Suspension Replacement.

END OF TASK

INSTALLATION

1. Install two spring seats (Figure 1, Item 14), adjustment plates (Figure 1, Item 13), and four rubber pads (Figure 1, Item 11) on spring (Figure 1, Item 8) and secure using eight bolts (Figure 1, Item 7), washers (Figure 1, Item 15), new locknuts (Figure 1, Item 16), and two spring cap ends (Figure 1, Item 12).
2. Repeat step 1 on opposite side of semitrailer.
3. Install four U-bolts (Figure 1, Item 17) on two spring cap ends (Figure 1, Item 12) and secure using 16 washers (Figure 1, Item 5) and eight hex nuts (Figure 1, Item 6).
4. Repeat step 3 on opposite side of semitrailer.
5. Install two washers (Figure 1, Item 3) and bushings (Figure 1, Item 19) on both sides of trunnion tube (Figure 1, Item 4).

INSTALLATION - CONTINUED

WARNING

The trunnion tube weighs 100 lb (45.4 kg) and requires two persons to lift. Failure to comply could result in injury to personnel.

6. Install trunnion tube (Figure 2, Item 4) using two U-bolts (Figure 2, Item 10), top plate (Figure 2, Item 9), upper trunnion hub (Figure 2, Item 18), lower trunnion hub (Figure 2, Item 20), four washers (Figure 2, Item 21), and four hex nuts (Figure 2, Item 22).
7. Repeat step 6 on opposite side of trunnion.
8. Install four hex bolts (Figure 2, Item 2) and hex nuts (Figure 2, Item 6) on two bottom brackets of trunnion center support.
9. Install eight bolts (Figure 2, Item 1), washers (Figure 2, Item 24), and new locknuts (Figure 2, Item 23) on trunnion center support.

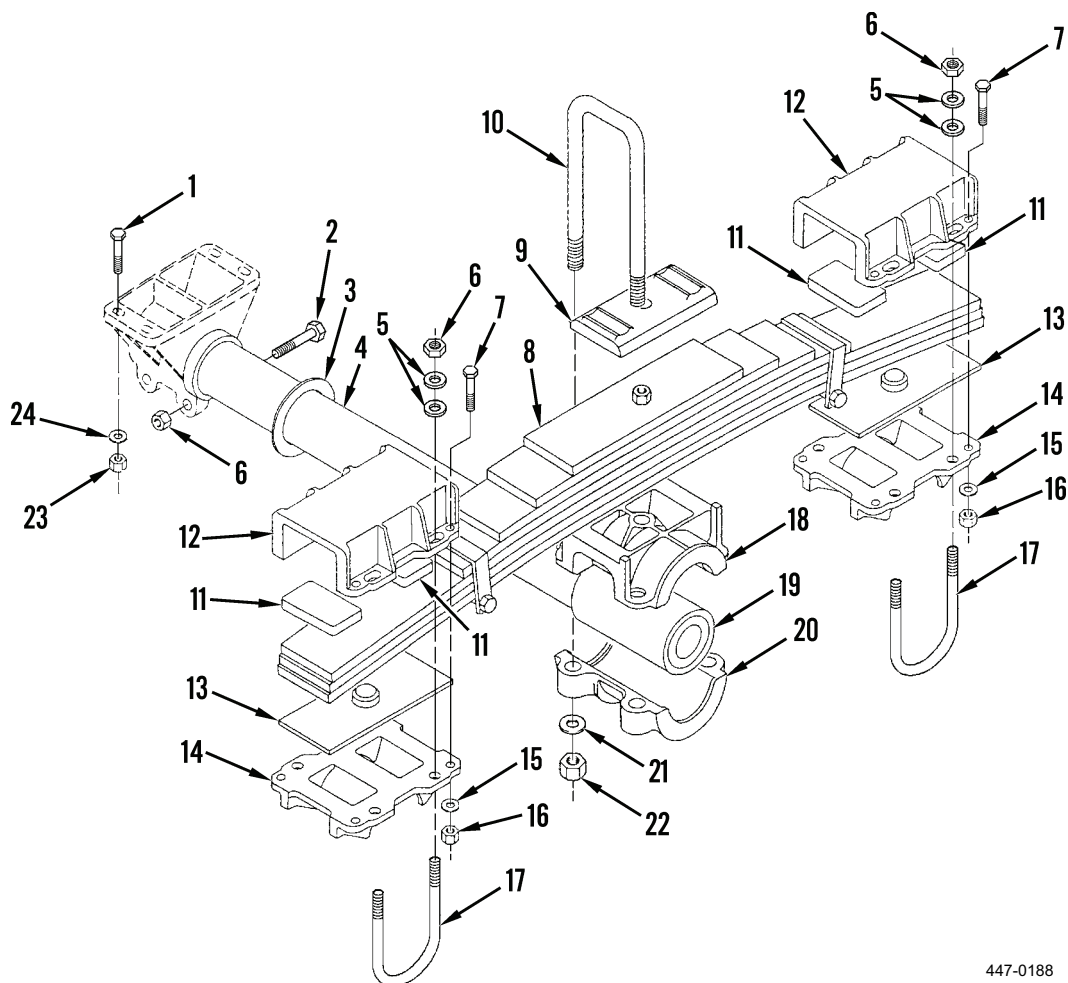

447-0188

Figure 2. Suspension Replacement.

INSTALLATION - CONTINUED

10. Torque suspension nuts to the following in-service DRY torque values:

1-1/8 in.- 12 UNF 880 lb-ft (1,193 Nm)

3/4 in.- 16 UNF 300 lb-ft (407 Nm)

5/8 in.- 18 UNF 180 lb-ft (244 Nm)

11. New replacement installations/hardware should have WET (oiled) fasteners. The following wet torque values apply:

1-1/8 in.- 12 UNF 670 lb-ft (908 Nm)

3/4 in.- 16 UNF 228 lb-ft (298 Nm)

5/8 in.- 18 UNF 130 lb-ft (176 Nm)

END OF TASK**FOLLOW-ON TASKS**

1. Align axles (WP 0111).
2. Install hubs and brake drums (WP 0033).
3. Install tires and wheels (WP 0021).
4. Connect semitrailer to prime mover.
5. Raise landing legs.
6. Road test to ensure safe operation and tracking of axles.

END OF TASK**END OF WORK PACKAGE**

DIRECT SUPPORT AND GENERAL SUPPORT MAINTENANCE
SUSPENSION REPLACEMENT (M871A2R)
Removal, Installation

INITIAL SETUP
Maintenance Level

Direct Support

Personnel Required

Four

Tools and Special Tools

Tool kit, general mechanic's (Item 4, WP 0082)
 Shop equipment, automotive maintenance and
 repair (Item 3, WP 0082)
 Floor jack
 Jack stands

References

WP 0111

Equipment Conditions

Landing legs down
 Semitrailer disconnected from prime mover
 Rear of semitrailer supported by jack stands
 Tires and wheels removed (WP 0021)
 Hubs and brake drums removed (WP 0033)

Materials/Parts

Locknut (32)

WARNING

- Jack must be positioned directly under axle to prevent slippage. Direct all personnel to stay clear of semitrailer when supported in the air. Failure to comply could result in injury or death to personnel or damage to equipment.
- To prevent shifting of semitrailer, floor jack should be used only on a hard, level surface. Use ground boards, if necessary. Chock tires. Failure to comply could result in injury or death to personnel.

REMOVAL

1. Remove eight bolts (Figure 1, Item 1), washers (Figure 1, Item 25), and locknuts (Figure 1, Item 24) from trunnion center support. Discard locknuts.
2. Remove four hex bolts (Figure 1, Item 2) and hex nuts (Figure 1, Item 10) from two bottom brackets of trunnion center support.

WARNING

The trunnion must be firmly supported with jack stands or floor jacks prior to performing steps 3 and 4. Failure to comply could result in injury to personnel and damage to equipment.

3. Remove four hex nuts (Figure 1, Item 22), washers (Figure 1, Item 21), and wear plate (Figure 1, Item 20) from two trunnion U-bolts (Figure 1, Item 4) and separate lower trunnion hub (Figure 1, Item 7) from upper trunnion hub (Figure 1, Item 5).
4. Repeat step 3 on opposite side of semitrailer.

WARNING

The trunnion tube weighs 100 lb. (45.5 kg) and requires two persons to lift. Failure to comply could result in injury to personnel.

5. Remove two washers (Figure 1, Item 23) and bushings (Figure 1, Item 6) from both sides of trunnion tube (Figure 1, Item 3) and remove trunnion tube from suspension.

WARNING

The axles must be firmly supported with jack stands or floor jacks prior to performing steps 6 thru 10. Failure to comply may result in injury to personnel.

6. Remove eight hex nuts (Figure 1, Item 10) and 16 washers (Figure 1, Item 9) from four U-bolts (Figure 1, Item 19) and remove U-bolts from two spring cap ends (Figure 1, Item 8).
7. Repeat step 6 on opposite side of semitrailer.

WARNING

Axles weigh 200 lb (40.7 kg) and require four persons to lift. Failure to comply could result in injury to personnel.

8. Remove eight bolts (Figure 1, Item 11), washers (Figure 1, Item 17), and locknuts (Figure 1, Item 18) from two spring cap ends (Figure 1, Item 8). Discard locknuts.
9. Remove two spring seats (Figure 1, Item 16), adjustment plates (Figure 1, Item 15), and four rubber pads (Figure 1, Items 13 and 14) from spring (Figure 1, Item 12).
10. Repeat steps 8 and 9 on opposite side of semitrailer.

REMOVAL - CONTINUED

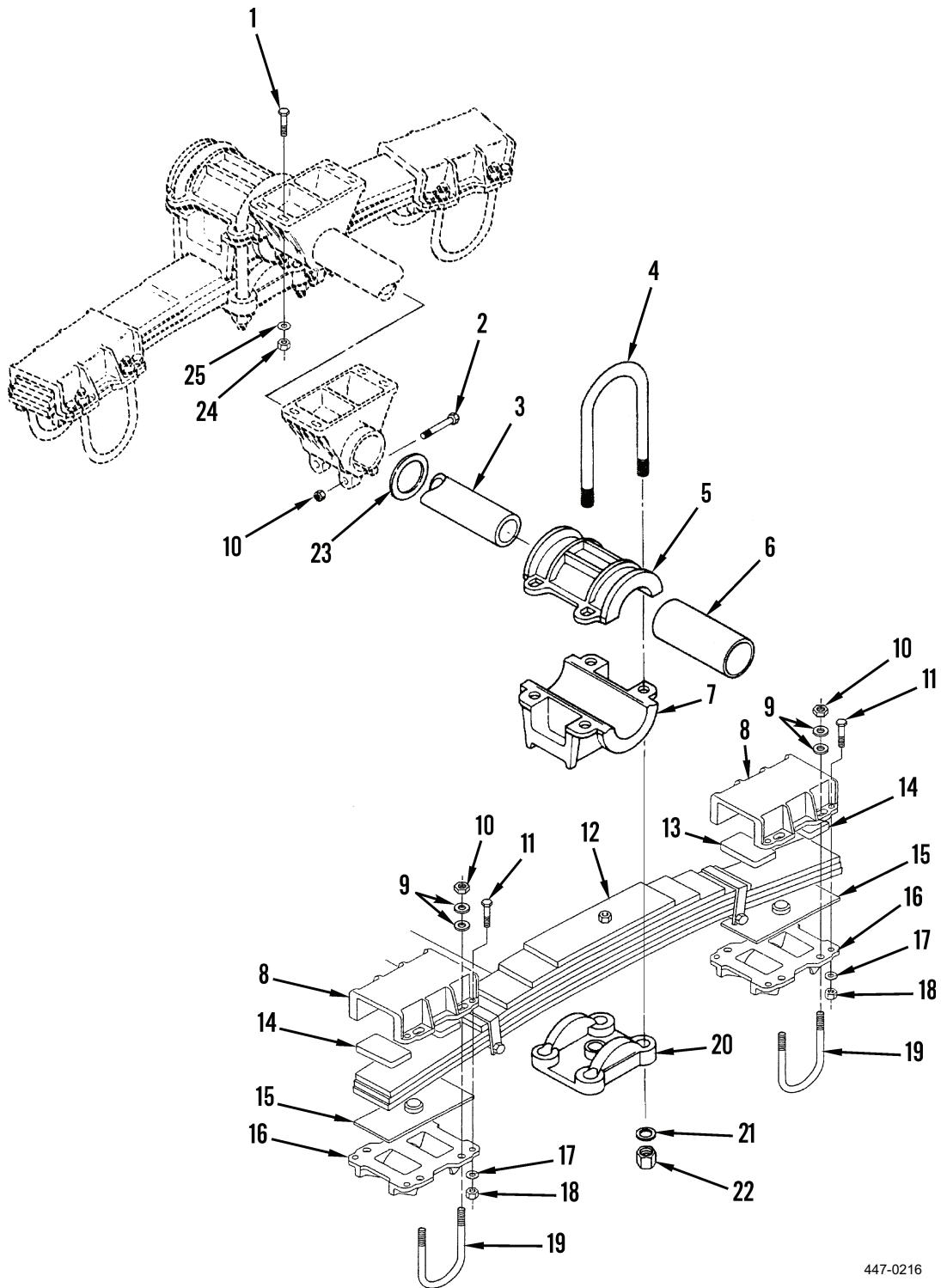

447-0216

Figure 1. Suspension Replacement.

END OF TASK

INSTALLATION

1. Install two spring seats (Figure 2, Item 16), adjustment plates (Figure 2, Item 15), and four rubber pads (Figure 2, Items 13 and 14) on spring (Figure 2, Item 12) and secure using eight bolts (Figure 2, Item 11), washers (Figure 2, Item 17), new locknuts (Figure 2, Item 18), and two spring cap ends (Figure 2, Item 8).
2. Repeat step 1 on opposite side of semitrailer.
3. Install four U-bolts (Figure 2, Item 19) on two spring cap ends (Figure 2, Item 8) and secure using 16 washers (Figure 2, Item 9) and eight hex nuts (Figure 2, Item 10).
4. Repeat step 3 on opposite side of semitrailer.
5. Install two washers (Figure 2, Item 23) and bushings (Figure 2, Item 6) on both sides of trunnion tube (Figure 2, Item 3).

WARNING

The trunnion tube weighs 100 lb (45.4 kg) and requires two persons to lift. Failure to comply could result in injury to personnel.

6. Install trunnion tube (Figure 2, Item 3) using two U-bolts (Figure 2, Item 4), wear plate (Figure 2, Item 20), upper trunnion hub (Figure 2, Item 5), lower trunnion hub (Figure 2, Item 7), four washers (Figure 2, Item 21), and four hex nuts (Figure 2, Item 22).
7. Repeat step 6 on opposite side of trunnion.
8. Install four hex bolts (Figure 2, Item 2) and hex nuts (Figure 2, Item 10) on two bottom brackets of trunnion center support.
9. Install eight bolts (Figure 2, Item 1), washers (Figure 2, Item 25), and new locknuts (Figure 2, Item 24) on trunnion center support.
10. Torque suspension nuts to the following in-service DRY torque values:
 - 1-1/8 in.- 12 UNF. 880 lb-ft (1,193 Nm)
 - 3/4 in.- 16 UNF 300 lb-ft (407 Nm)
 - 5/8 in.- 18 UNF 180 lb-ft (244 Nm)
11. New replacement installations/hardware should have WET (oiled) fasteners. The following wet torque values apply:
 - 1-1/8 in.- 12 UNF. 670 lb-ft (908 Nm)
 - 3/4 in.- 16 UNF 228 lb-ft (298 Nm)
 - 5/8 in.- 18 UNF 130 lb-ft (176 Nm)

INSTALLATION - CONTINUED

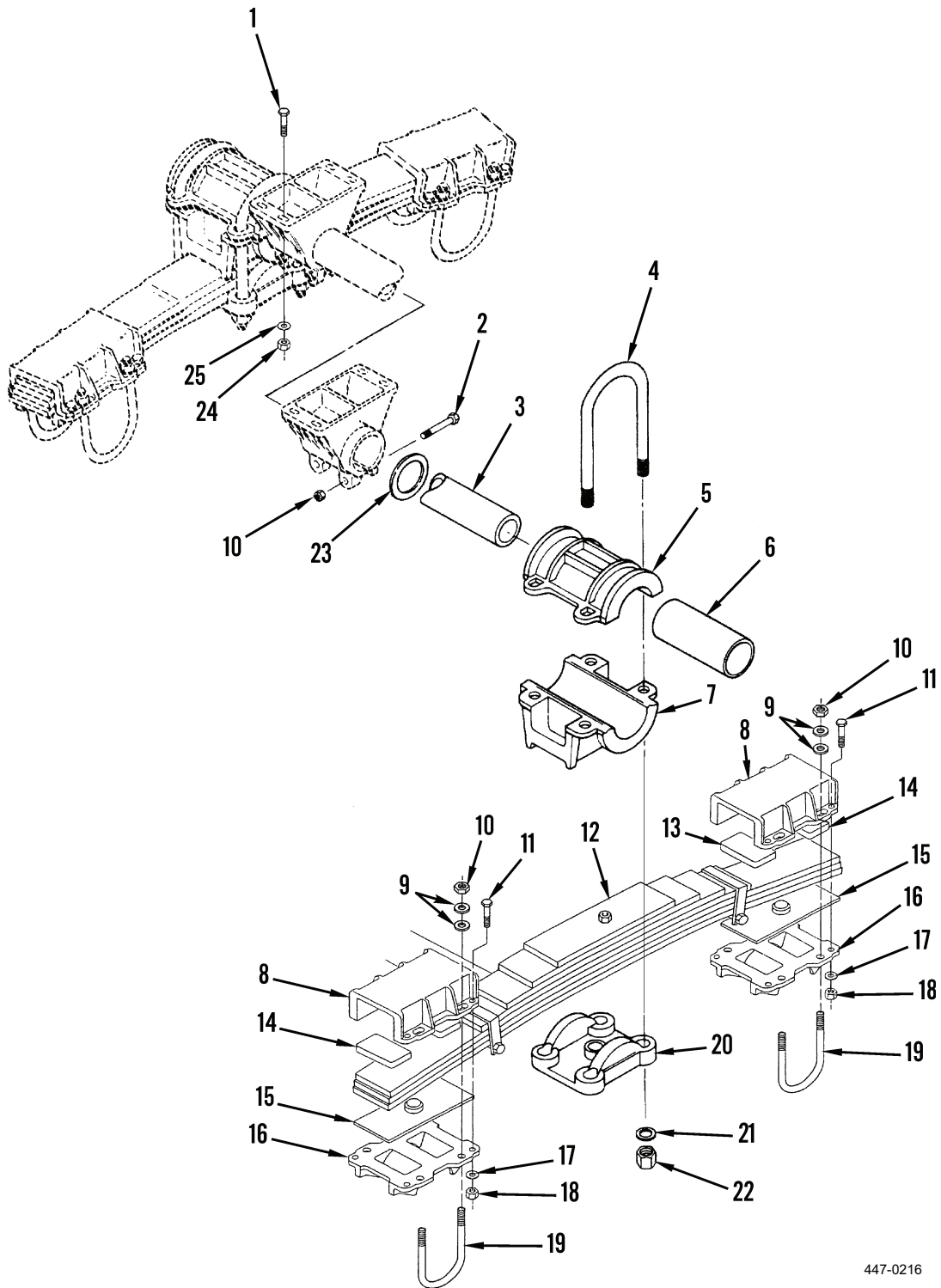

447-0216

Figure 2. Suspension Replacement.

END OF TASK

FOLLOW-ON TASKS

1. Align axles (WP 0111).
2. Install hubs and brake drums (WP 0033).
3. Install tires and wheels (WP 0021).
4. Connect semitrailer to prime mover.
5. Raise landing legs.
6. Road test to ensure safe operation and tracking of axles.

END OF TASK**END OF WORK PACKAGE**

DIRECT SUPPORT AND GENERAL SUPPORT MAINTENANCE
FRAME REPAIR

INITIAL SETUP**Maintenance Level**

General Support

References

TB 9-2510-242-40

Refer to TB 9-2510-242-40 for repair of frame.

END OF TASK**END OF WORK PACKAGE**

DIRECT SUPPORT AND GENERAL SUPPORT MAINTENANCE
KINGPIN REPLACEMENT (M871R AND M871A1R)
Removal, Installation

INITIAL SETUP
Maintenance Level

General Support

Personnel Required

Two

Tools and Special Tools

Tool kit, general mechanic's (Item 4, WP 0082)
 Shop equipment, automotive maintenance and repair (Item 3, WP 0082)
 Shop equipment, welding, field maintenance (Item 7, WP 0082)

Equipment Conditions

Landing legs down
 Semitrailer disconnected from prime mover
 Tires chocked
 Ground boards emplaced

REMOVAL

1. Remove middle metal plate to gain access to top surface of kingpin (Figure 1, Item 1).

WARNING

- Particles blown by compressed air are hazardous. DO NOT exceed 15 psi (103 kPa) nozzle pressure when drying parts with compressed air. Use a maximum of 30 psi (207 kPa) when cleaning components. DO NOT direct compressed air against human skin. To prevent injury, user must wear protective goggles or face shield. Make sure air stream is directed away from user and other personnel in the area. Failure to follow this warning may result in injury to personnel.
 - Wear welding mask, gloves, and apron when welding or using cutting torch. Failure to wear adequate protective clothing may result in injury to personnel.
2. Using air-arc process, remove welds securing the kingpin (Figure 1, Item 1) upper surface and plug welds from kingpin 5-1/2-in.-square base. A 300-amp welder is required along with a "shop air" supply of 90 psi (621 kPa). Care must be taken to minimize damage to bolster plate. Damage to kingpin being removed is of no consequence.
 3. Remove kingpin (Figure 1, Item 1).

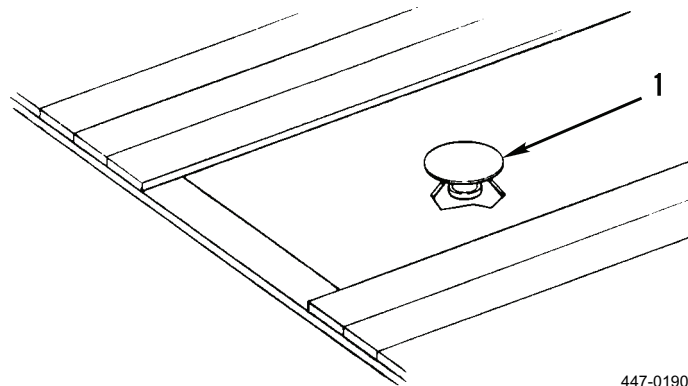

447-0190

Figure 1. Kingpin Removal.

END OF TASK

INSTALLATION

WARNING

- Wear welding mask, gloves, and apron when welding or using cutting torch. Failure to wear adequate protective clothing may result in injury to personnel.
 - Eye protection is required. Particles from grinding operations are hazardous to the eyes.
1. Grind area of bolster plate under kingpin (Figure 2, Item 1) 5-1/2-in.-square base flush so that new kingpin will lie flat on the bolster plate.
 2. Install new kingpin (Figure 2, Item 1). Locate holes in kingpin top in the same manner as the one removed.
 3. Preheat kingpin (Figure 2, Item 1) and bolster plate to 150°F (66°C), and maintain temperature throughout the welding process.
 4. Weld kingpin (Figure 2, Item 1) 5-1/2-in.-square base to bolster plate with 1/4 in. fillet weld 2 in. (51 mm) long at four equally spaced points on the edge of the flange and plug weld the holes in the 5-1/2-in.-square base. Welds are to be in accordance with MIL-STD-1261, class 3. Use 100,000 psi electrode or wire of the following specifications: electrodes, mineral coated, low hydrogen, MIL-E-2200/6 type MIL-10015 or MIL-10016. Wire, use bare solid wire, low alloy steel, MIL-E-23765/2 type 100S-1, 100S-2 or 110S-1.
 5. Inspect weld with dye penetrant or magnetic particle inspection. No cracks are allowable and any cracks found must be repaired.
 6. Prime and paint the top of the kingpin (Figure 2, Item 1) and bolster plate as follows: Prime, per MIL-DTL-0053030 or MIL-DTL-0053022. Paint with enamel per MIL-DTL-53039 or MIL-DTL-64159.
 7. Replace middle metal plate that was removed to gain access to the top of the kingpin (Figure 2, Item 1).

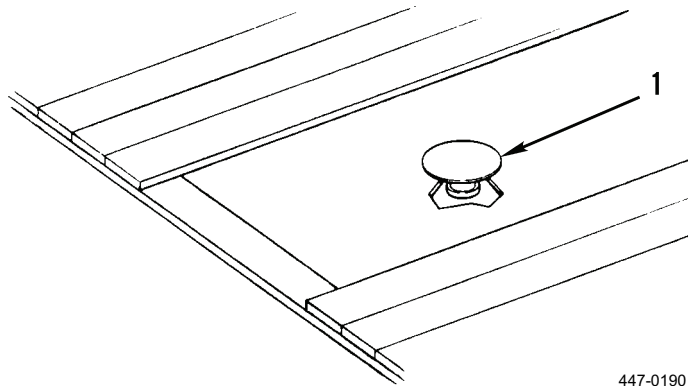

Figure 2. Kingpin Installation.

END OF TASK

FOLLOW-ON TASKS

1. Connect semitrailer to prime mover.
2. Raise landing legs.
3. Remove/store chocks and ground boards.

END OF TASK

END OF WORK PACKAGE

DIRECT SUPPORT AND GENERAL SUPPORT MAINTENANCE**KINGPIN REPLACEMENT (M871A2R)****Removal, Installation**

INITIAL SETUP**Maintenance Level**

General Support

Personnel Required

Two

Tools and Special Tools

Tool kit, general mechanic's (Item 4, WP 0082)
Shop equipment, automotive maintenance and
repair (Item 3, WP 0082)
Shop equipment, welding, field maintenance
(Item 7, WP 0082)

Equipment Conditions

Landing legs down
Semitrailer disconnected from prime mover
Tires chocked
Ground boards emplaced

REMOVAL

WARNING

- Particles blown by compressed air are hazardous. DO NOT exceed 15 psi (103 kPa) nozzle pressure when drying parts with compressed air. Use a maximum of 30 psi (207 kPa) when cleaning components. DO NOT direct compressed air against human skin. To prevent injury, user must wear protective goggles or face shield. Make sure air stream is directed away from user and other personnel in the area. Failure to follow this warning may result in injury to personnel.
- Wear welding mask, gloves, and apron when welding or using cutting torch. Failure to wear adequate protective clothing may result in injury to personnel.

1. Measure from floor side of bulkhead (Figure 1, Item 1) and mark two straight lines on top metal plate (Figure 1, Item 2) between main beams (Figure 1, Item 3) at locations shown.
2. Using the air-arc process, make two straight cuts in top metal plate (Figure 1, Item 2) between main beams (Figure 1, Item 3) at locations marked.
3. Air-arc the existing welds securing the metal plate (Figure 1, Item 2) to the main beams (Figure 1, Item 3).
4. Remove the cut out section of metal plate (Figure 1, Item 2) to gain access to top of kingpin.
5. Using the air-arc process, remove the welds securing the kingpin (Figure 1, Item 4) 8-in.-round base to the bolster plate (Figure 1, Item 5). A 300-amp welder is required along with a shop air supply of 90 psi (621 kPa). Care must be taken to minimize damage to the bolster plate (Figure 1, Item 5).
6. Remove and discard the kingpin (Figure 1, Item 4).

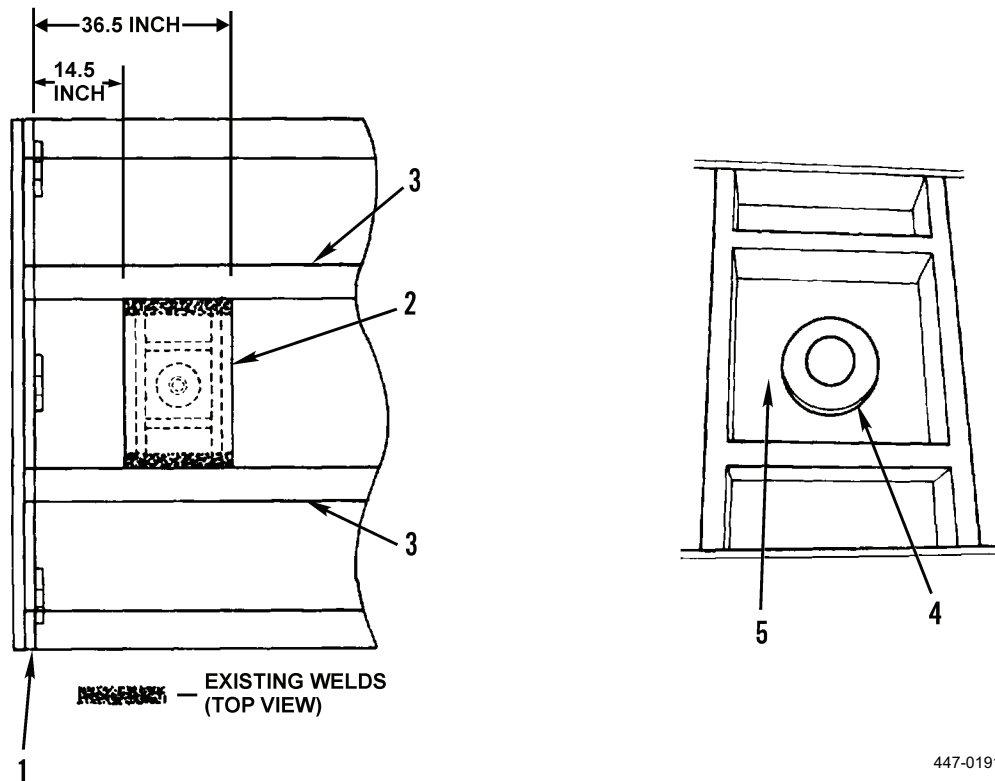

447-0191

Figure 1. Kingpin Replacement.

END OF TASK

INSTALLATION**WARNING**

- Wear welding mask, gloves, and apron when welding or using cutting torch. Failure to wear adequate protective clothing may result in injury to personnel.
 - Eye protection is required. Particles from grinding operations are hazardous to the eyes.
1. Grind the area of the bolster plate (Figure 1, Item 5) under the kingpin (Figure 1, Item 4) 8-in.-round base flush so that the new kingpin will lie flat on the bolster plate.
 2. Position new kingpin (Figure 1, Item 4) on bolster plate (Figure 1, Item 5).
 3. Drop a plumb line and bob from kingpin (Figure 1, Item 4) to ground and mark spot with a chalk mark (Figure 2).

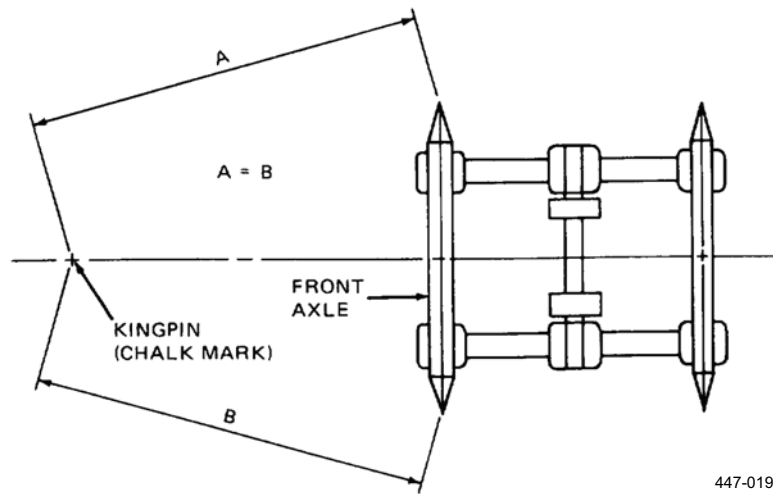
**Figure 2. Kingpin Placement.**

INSTALLATION - CONTINUED

4. To center the kingpin (Figure 3, Item 4), measure the distance from the chalk mark to the center of the hub cap plugs on the front axle (Figure 2, A and B). The difference between measurements should be no more than 3/8 in.
5. If the measurements are not correct, adjust position of kingpin (Figure 3, Item 4) on bolster plate (Figure 3, Item 5) until measurements are within limits.

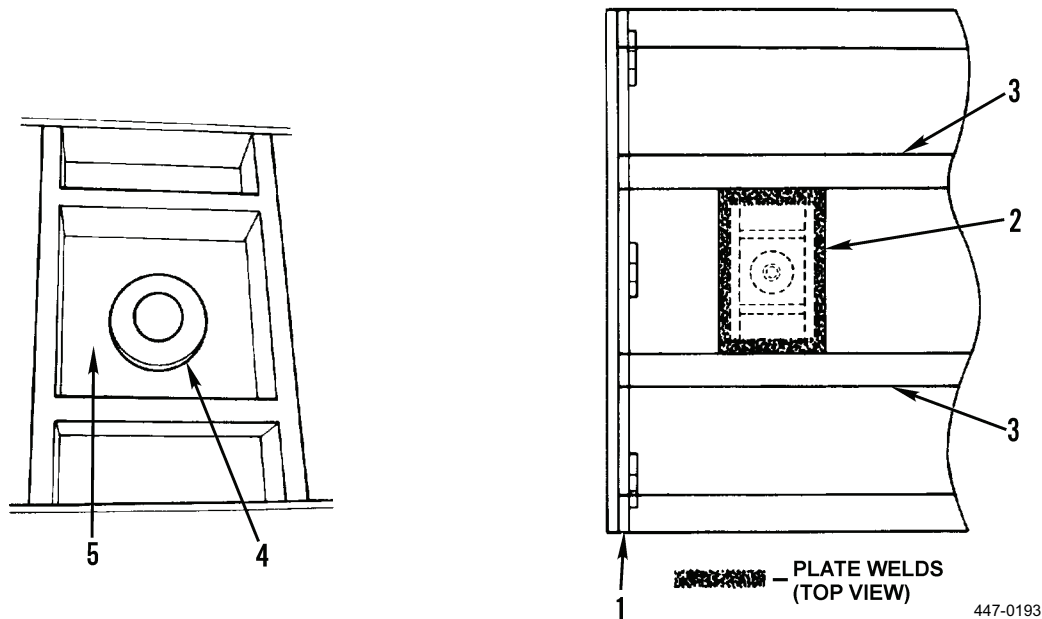
**Figure 3. Center Kingpin.****WARNING**

Wear welding mask, gloves, and apron when welding or using cutting torch. Failure to wear adequate protective clothing may result in serious injury.

6. Weld the kingpin (Figure 3, Item 4) 8-in.-round base to the bolster plate (Figure 3, Item 5) with a continuous 5/8-in. fillet weld. Welds are to be in accordance with MIL-STD-1261, class 3. Use 70,000 psi electrode or wire of the following specification: electrodes, mineral coated, low hydrogens MIL-E-2200/6 type MIL-10015 or MIL-10016. Wire, use bare solid wire, low alloy steel, MIL-E-23765/2 type 100S-1 or 110S-1.
7. Repeat step 6 two times to obtain a continuous 3-pass weld on the kingpin.
8. Inspect kingpin weld and the air-arc cut edges with dye penetrant or magnetic particle inspection. No cracks are allowable. Any cracks found must be ground out or otherwise repaired.
9. Weld into place the top metal plate (Figure 3, Item 2) that was removed to gain access to the kingpin.
10. Prime and paint the top metal plate (Figure 3, Item 2) as follows: prime, per TT-P-636 or TT-P-634. Paint using chemical Agent Resistant Coating (CARC) per MIL-DTL-53039 or MIL-DTL-64159.

END OF TASK

FOLLOW-ON TASKS

1. Connect semitrailer to primer mover.
2. Raise landing legs.
3. Remove/store chocks and ground boards.

END OF TASK**END OF WORK PACKAGE**

DIRECT SUPPORT AND GENERAL SUPPORT MAINTENANCE**TIRE REPAIR**

INITIAL SETUP**Maintenance Level**

General Support

ReferencesTM 9-2610-200-14

Refer to TM 9-2610-200-14 for instructions on tire maintenance.

END OF TASK**END OF WORK PACKAGE**

CHAPTER 10
PARTS INFORMATION

FIELD AND SUSTAINMENT MAINTENANCE
REPAIR PARTS AND SPECIAL TOOLS LIST INTRODUCTION

SCOPE

This RPSTL lists and authorizes spares and repair parts for performance of Field level maintenance of the semitrailers. It authorizes the requisitioning, issue, and disposition of spares and repair parts as indicated by the source, maintenance, and recoverability (SMR) codes.

GENERAL

In addition to the Introduction work package, this RPSTL is divided into the following work packages:

- a. **Repair Parts Lists Work Package.** Work package containing lists of spares and repair parts authorized by this RPSTL for use in the performance of maintenance. This work package also includes parts which must be removed for replacement of the authorized parts. Parts lists are composed of functional groups in ascending alphanumeric sequence, with the parts in each group listed in ascending figure and item number sequence. Repair parts kits are listed separately in their own functional group. Items listed are shown on the associated illustrations.
- b. **Special Tools List Work Package.** There are no special tools for the semitrailer.
- c. **Cross-Reference Indexes Work Package.** There are two cross-reference indexes in this RPSTL: National Stock Number Index and Part Number Index.

EXPLANATION OF COLUMNS IN THE REPAIR PARTS LISTS

- 1. **Item No. (Column 1).** Indicates the number used to identify items called out in the illustration.
- 2. **SMR Code (Column 2).** The SMR code containing supply/requisitioning information, maintenance level authorization criteria, and disposition instruction, as shown in the following breakout:

SOURCE CODE	MAINTENANCE CODE		RECOVERABILITY CODE
XXxxx	xxXXx		xxxxX
1st two positions	3rd position	4th position	5th position
How you get an item.	Who can install, replace, or use the item.	Who can do complete repair* on the item.	Who determines disposition action on an unserviceable item.

* *Complete Repair:* Maintenance capacity, capability, and authority to perform all corrective maintenance tasks of the "Repair" function in a use/user environment in order to restore serviceability to a failed item.

EXPLANATION OF COLUMNS IN THE REPAIR PARTS LISTS - CONTINUED

- a. **Source Code.** The source code tells you how to get an item needed for maintenance, repair, or overhaul of an end item/equipment. Explanations of source codes follow:

Code	Application/Explanation
PA PB PC PD PE PF PG	<p>Stocked items; use the applicable NSN to request/requisition items with these source codes. They are authorized to the maintenance category indicated by the code entered in the third position of the SMR code.</p> <p style="text-align: center;"><i>Items coded PC are subject to deterioration.</i></p> <p>.....</p>
KD KF KB	<p>Items with these codes are not to be requested/requisitioned individually. They are part of a kit which is authorized to the maintenance level indicated in the third position of the SMR code. The complete kit must be requisitioned and applied.</p> <p>.....</p>
MO - Made at Unit/ AVUM level MF - Made at DS/AVIM Level MH - Made at GS Level ML - Made at SRA MD - Made at Depot	<p>Items with these codes are not to be requested/requisitioned individually. They must be made from bulk materiel which is identified by the part number in the DESCRIPTION AND USABLE ON CODE (UOC) column and listed in the bulk materiel group work package of the RPSTL. If the item is authorized to you by the third position of the SMR code, but the source code indicates it is made at a higher level, order the item from the higher level of maintenance.</p> <p>.....</p>
AO-Assembled by Unit/ AVUM level AF-Assembled by DS/ AVIM level AH-Assembled by GS level AL-Assembled by SRA AD-Assembled by Depot	<p>Items with these codes are not to be requested/requisitioned individually. The parts that make up the assembled item must be requisitioned or fabricated and assembled at the level of maintenance indicated by the source code. If the third position of the SMR code authorizes you to replace the item, but the source code indicates the item is assembled at a higher level, order the item from the higher level of maintenance.</p>
XA	Do not requisition an "XA" coded item. Order the next higher assembly (refer to NOTE below).
XB	If an item is not available from salvage, order it using the CAGEC and P/N.
XC	Installation drawings, diagrams, instruction sheets, field service drawings; identified by manufacturer's P/N.
XD	Item is not stocked. Order an XD-coded item through normal supply channels using the CAGEC and P/N given, if no NSN is available.

NOTE

Cannibalization of controlled exchange, when authorized, may be used as a source of supply for items with the above source codes, except for those source coded "XA" or those aircraft support items restricted by requirements of AR 750-1.

EXPLANATION OF COLUMNS IN THE REPAIR PARTS LISTS - CONTINUED

b. **Maintenance Code.** Maintenance codes tell you the level(s) of maintenance authorized to use and repair support items. The maintenance codes are entered in the third and fourth positions of the SMR code as follows:

(a) Third Position. The maintenance code entered in the third position tells you the lowest maintenance level authorized to remove, replace, and use an item. The maintenance code entered in the third position will indicate authorization to one of the following levels of maintenance:

Code	Application/Explanation
C	Crew or Operator maintenance done within Field/AVUM maintenance.
O	Unit Level/AVUM maintenance can remove, replace, and use the item.
F	Direct Support/AVIM maintenance can remove, replace, and use the item.
H	General Support maintenance can remove, replace, and use the item.
L	Specialized Repair Activity (SRA) can remove, replace, and use the item.
D	Depot Maintenance can remove, replace, and use the item.

(b) Fourth Position. The maintenance code entered in the fourth position tells you whether or not the item is to be repaired and identifies the lowest maintenance level with the capability to do complete repair (perform all authorized repair functions).

NOTE

Some limited repair may be done on the item at a lower level of maintenance, if authorized by the Maintenance Allocation Chart (MAC) and SMR codes.

Code	Application/Explanation
O	Unit/AVUM is the lowest level that can do complete repair of the item.
F	Direct Support/AVIM is the lowest level that can do complete repair of the item.
H	General Support is the lowest level that can do complete repair of the item.
L	Specialized Repair Activity (SRA) is the lowest level that can do complete repair of the item.
D	Depot is the lowest level that can do complete repair of the item.
Z	Nonrepairable. No repair is authorized.
B	No repair is authorized. No parts or special tools are authorized for the maintenance of a "B"-coded item. However, the item may be reconditioned by adjusting, lubricating, etc., at the user level.

EXPLANATION OF COLUMNS IN THE REPAIR PARTS LISTS - CONTINUED

- c. **Recoverability Code.** Recoverability codes are assigned to items to indicate the disposition action on unserviceable items. The recoverability code is entered in the fifth position of the SMR code as follows:

Code	Application/Explanation
Z.	Nonrepairable item. When unserviceable, condemn and dispose of the item at the level of maintenance shown in the third position of the SMR code.
O.	Reparable item. When uneconomically reparable, condemn and dispose of the item at the Unit level maintenance.
F.	Reparable item. When uneconomically reparable, condemn and dispose of the item at Direct Support level.
H.	Reparable item. When uneconomically reparable, condemn and dispose of the item at General Support level.
D.	Reparable item. When beyond lower level repair capability, return to depot. Condemnation and disposal of item are not authorized below depot level.
L.	Reparable item. Condemnation and disposal of item not authorized below Specialized Repair Activity (SRA).
A.	Item requires special handling or condemnation procedures because of specific reasons (e.g., precious metal content, high dollar value, critical material, or hazardous material). Refer to appropriate manuals/directives for specific instructions.

3. **NSN - (Column 3).** The NSN for the item is listed in this column.
4. **CAGEC (Column 4).** The Commercial and Government Entity Code (CAGEC) is a five-digit code which is used to identify the manufacturer, distributor, or Government agency/activity that supplies the item.
5. **PART NUMBER (Column 5).** Indicates the primary number used by the manufacturer (individual, company, firm, corporation, or Government activity), which controls the design and characteristics of the item by means of its engineering drawings, specifications, standards, and inspection requirements to identify an item or range of items.

NOTE

When you use an NSN to requisition an item, the item you receive may have a different part number from the part ordered.

6. **DESCRIPTION AND USABLE ON CODE (UOC) (Column 6).** This column includes the following information:
 - a. The Federal item name and, when required, a minimum description to identify the item.
 - b. P/Ns of bulk materials are referenced in this column in the line entry to be manufactured or fabricated.
 - c. Hardness Critical Item (HCI). A support item that provides the equipment with special protection from electromagnetic pulse (EMP) damage during a nuclear attack.
 - d. The statement END OF FIGURE appears just below the last item description in column (6) for a given figure in both the repair parts list and special tools list work packages.
7. **QTY (Column 7).** The QTY (quantity per figure) column indicates the quantity of the item used in the breakout shown on the illustration/figure, which is prepared for a functional group, subfunctional group, group or an assembly. A "V" appearing in this column in lieu of a quantity indicates that the quantity is variable and the quantity may vary from application to application.

EXPLANATION OF CROSS-REFERENCE INDEXES WORK PACKAGE FORMAT AND COLUMNS

1. **National Stock Number (NSN) Index Work Package.**

- a. **STOCK NUMBER Column.** This column lists the NSN by National Item Identification Number (NIIN) sequence. The NIIN consists of the last nine digits of the NSN (i.e., NSN 5305-01-674-1467). When using this column to locate an item, ignore the first four digits of the NSN. However, the complete NSN should be used when ordering items by stock number.
- b. **FIG. Column.** This column lists the number of the figure where the item is identified/located. The figures are in numerical order in WP 0078 00.
- c. **ITEM Column.** The item number identifies the item associated with the figure listed in the adjacent FIG. column. This item is also identified by the NSN listed on the same line.

2. **Part Number (P/N) Index Work Package.** Part numbers in this index are listed in ascending alphanumeric sequence (i.e., vertical arrangement of letter and number combination which places the first letter or digit of each group in order A through Z, followed by the numbers 0 through 9 and each following letter or digit in like order).

- a. **PART NUMBER Column.** Indicates the P/N assigned to the item.
- b. **FIG. Column.** This column lists the number of the figure where the item is identified/located in the repair parts list and special tools list work packages.
- c. **ITEM Column.** The item number is the number assigned to the item as it appears in the figure referenced in the adjacent figure number column.

SPECIAL INFORMATION

- 1. **Usable On Code (UOC).** The UOC appears in the lower left corner of the DESCRIPTION column heading. Usable on codes are shown as “UOC:” in the Description Column (justified left) on the first line under the applicable item/nomenclature. Uncoded items are applicable to all models. Identification of the UOC’s used in the RPSTL are:

<u>Code</u>	<u>Used On</u>
SCB	M817A1R Semitrailer
SJB	M871R Semitrailer
SKB	M871A2R Semitrailer

- 2. **Associated Publications.** The publication(s) listed below pertain to the semitrailers and its components:

Publication	Short Title
TM 9-2330-335 Series	Semitrailers

HOW TO LOCATE REPAIR PARTS

1. **When National Stock Number is Known.**

- a. **First.** If you have the NSN, look in the STOCK NUMBER column of the NSN index work package. The NSN is arranged in NIIN sequence. Note the figure and item number next to the NSN.
- b. **Second.** Turn to the figure and locate the item number. Verify that the item is the one you are looking for.

2. **When Part Number is Known.**

- a. **First.** If you have the P/N and not the NSN, look in the PART NUMBER column of the P/N index work package. Identify the figure and item number.
- b. **Second.** Look up the item on the figure in the applicable repair parts list work package.

ABBREVIATIONS

For standard abbreviations see ASME Y14.38-1999, *Abbreviations and Acronyms*.

<u>Abbreviation</u>	<u>Explanation</u>
NIIN	National Item Identification Number (consists of the last 9 digits of the NSN)
RPSTL	Repair Parts and Special Tools Lists
SMR	Source, Maintenance, and Recoverability Code
TMDE	Test, Measurement, and Diagnostic Equipment

END OF WORK PACKAGE

**FIELD AND SUSTAINMENT MAINTENANCE
REPAIR PARTS LIST**

1
2 AND 3

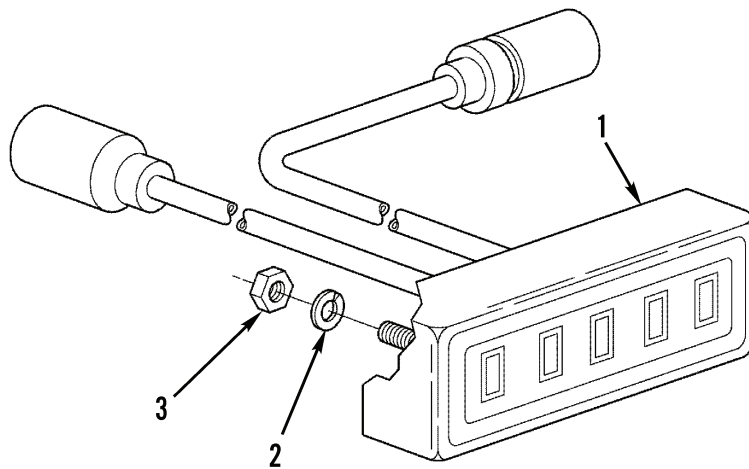

Figure 1. Blackout Light.

447-5001

(1) ITEM NO	(2) SMR CODE	(3) NSN	(4) CAGEC	(5) PART NUMBER	(6) DESCRIPTION AND USABLE ON CODES (UOC)	(7) QTY
-------------------	--------------------	------------	--------------	-----------------------	--	------------

GROUP 06 ELECTRICAL SYSTEM

GROUP 0609 LIGHTS

FIG. 1 BLACKOUT LIGHT

1	PFOZZ	6220010885915	5A910	12258212	LIGHT, BLACKOUT.....	2
2	PAOZZ	5310000453299	80205	MS35338-42	.WASHER, LOCK.....	2
3	PAOZZ	5310009349757	80205	MS35649-282	.NUT, PLAIN, HEXAGON.....	2

END OF FIGURE

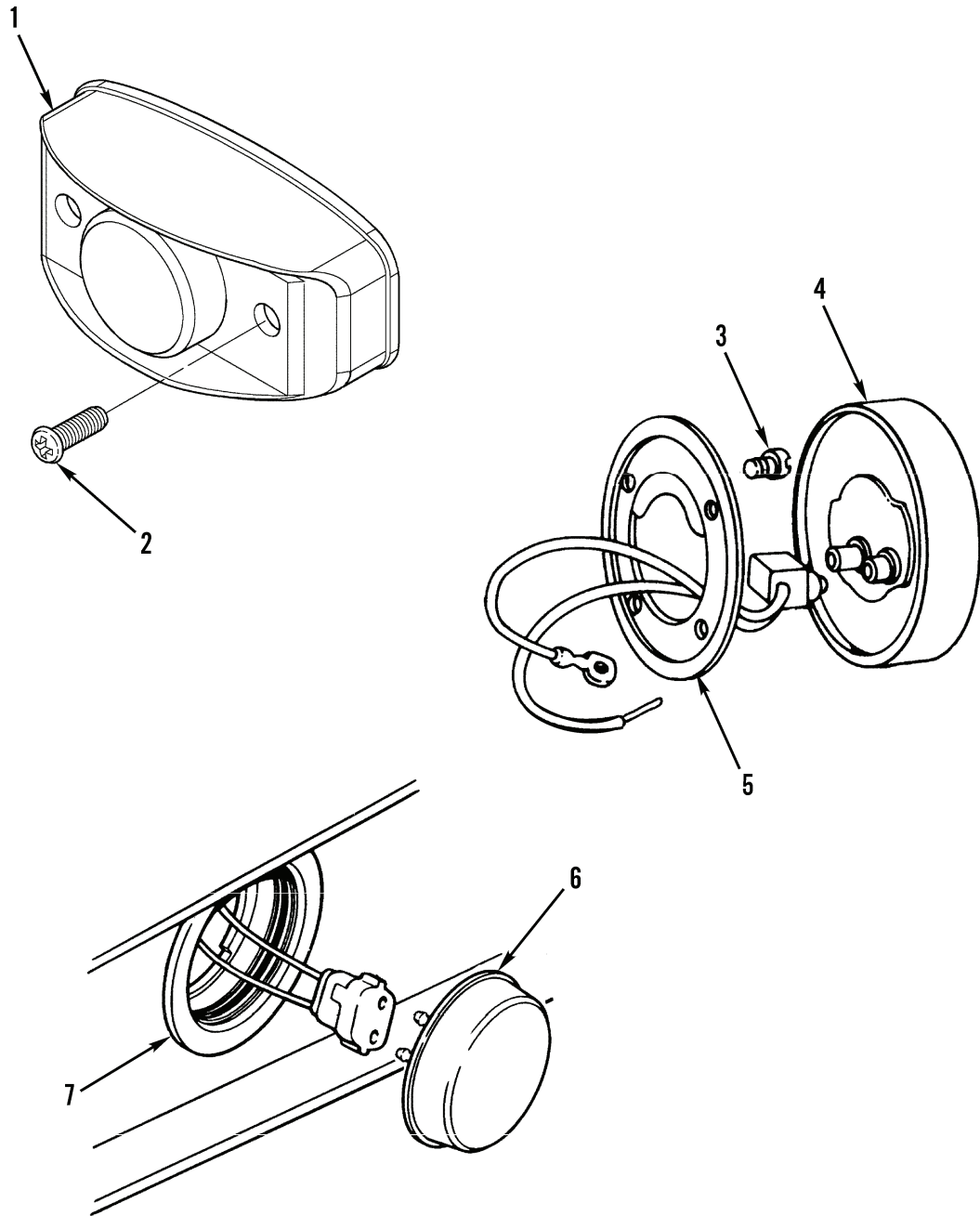

Figure 2. Clearance Lights.

(1) ITEM NO	(2) SMR CODE	(3) NSN	(4) CAGEC	(5) PART NUMBER	(6) DESCRIPTION AND USABLE ON CODES (UOC)	(7) QTY
-------------------	--------------------	------------	--------------	-----------------------	--	------------

GROUP 0609 LIGHTS

FIG. 2 CLEARANCE LIGHTS

1	PFOZZ	6220014826113	13548	07406	LIGHT, MARKER, CLEARA RED.....	5
1	PFOZZ	6220014825574	13548	07407	LIGHT, MARKER, CLEARA AMBER MIDSHIP..	2
2	PAOZZ	5305014993342	0FBD6	52100013	SCREW, TAPPING.....	20
3	PFOZZ	5305014995551	0FBD6	52100010	SCREW, TAPPING 0.25 X 0.70".....	8
					UOC: SJB	
4	PFOZZ	6220014825444	13548	30255R	LAMP UNIT, VEHICULAR RED REAR SIDES.	2
					UOC: SCB, SJB	
5	PFOZZ	2590015562096	13548	30720	GROMMET, NONMETALL USED ON M871R	4
					ONLY.....	
					UOC: SJB	
6	PFOZZ	6220014825320	13548	30255Y	LAMP UNIT, VEHICULAR AMBER FRONT....	2
7	PFOZZ	5325015561398	3DGR3	50824018	GROMMET, NONMETALL M871R ONLY USES 2	4

END OF FIGURE

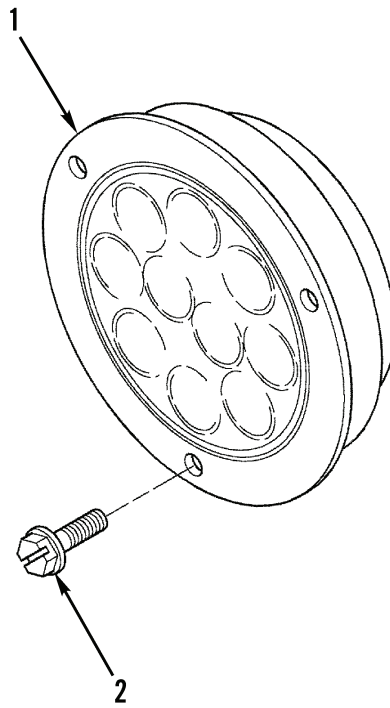

Figure 3. LED Taillight.

447-5003

(1) ITEM NO	(2) SMR CODE	(3) NSN	(4) CAGEC	(5) PART NUMBER	(6) DESCRIPTION AND USABLE ON CODES (UOC)	(7) QTY
-------------------	--------------------	------------	--------------	-----------------------	--	------------

GROUP 0609 LIGHTS

FIG. 3 LED TAILLIGHT

1	PFOZZ	6220014993350	0FBD6	50920012	LIGHT SET, STOP LIGH RED LED.....	4
2	PAOZZ	5305014995551	0FBD6	52100010	SCREW, TAPPING 0.25 X 0.70".....	12

END OF FIGURE

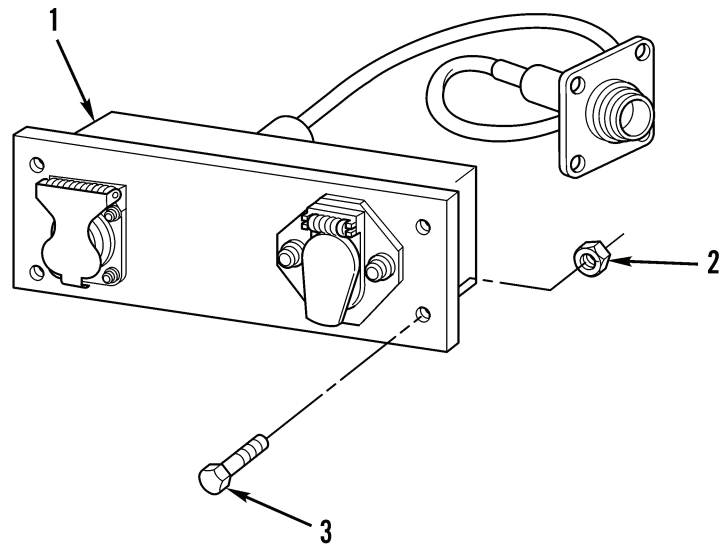

Figure 4. Converter Assembly Unit.

447-5004

(1) ITEM NO	(2) SMR CODE	(3) NSN	(4) CAGEC	(5) PART NUMBER	(6) DESCRIPTION AND USABLE ON CODES (UOC)	(7) QTY
-------------------	--------------------	------------	--------------	-----------------------	--	------------

GROUP 0613 HULL OR CHASSIS WIRING
HARNESS

FIG. 4 CONVERTER ASSEMBLY UNIT

1	PFOZZ	6130015561480	60359	UTM-2412	POWER SUPPLY PART FOR CORE CREDIT..	1
2	PAOZZ	5310008140673	81349	M45913/3-5CG8C	NUT, SELF-LOCKING, HE 5/16-18.....	4
3	PAOZZ	5305002264831	80204	B1821BH031C150N	SCREW, CAP, HEXAGON H 5/16-18 X 1.50.	4

END OF FIGURE

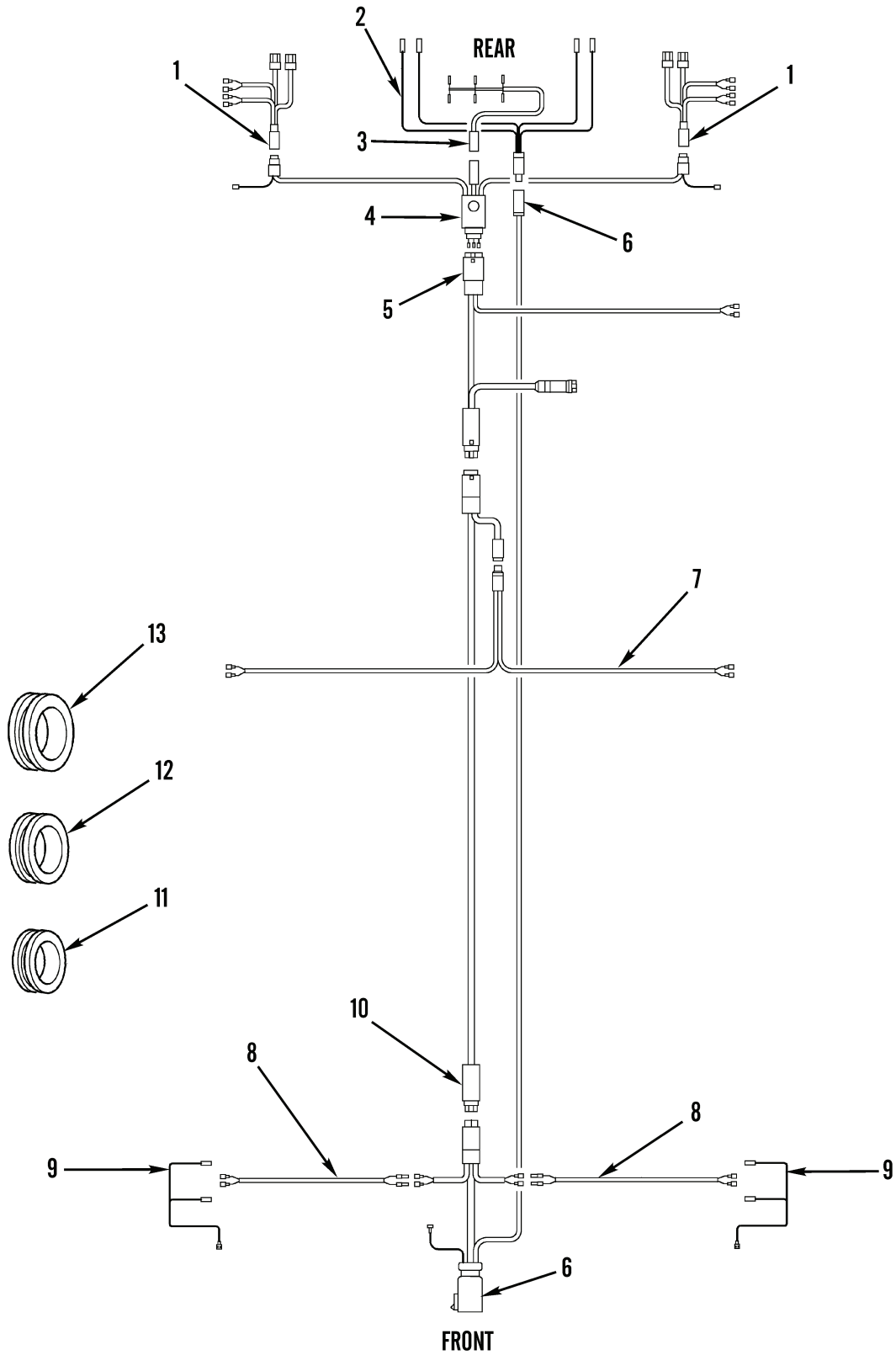

Figure 5. Chassis Wiring Harness.

447-5005

(1) ITEM NO	(2) SMR CODE	(3) NSN	(4) CAGEC	(5) PART NUMBER	(6) DESCRIPTION AND USABLE ON CODES (UOC)	(7) QTY
GROUP 0613 HULL OR CHASSIS WIRING HARNESS						
FIG. 5 CHASSIS WIRING HARNESS						
1	PFOZZ	6150014993332	64466	28161-028	WIRING HARNESS.....	2
2	PFOZZ	6150014993289	3DGR3	50851109	WIRING HARNESS BLACK-OUT.....	1
3	PFOZZ	6150014993311	64466	72203-012	WIRING HARNESS.....	1
4	PFOZZ	6150014993315	64466	25150-028	WIRING HARNESS REAR.....	1
5	PFOZZ	6150014993320	64466	17900-086	WIRING HARNESS ABS MAIN.....	1
6	PFOZZ	6150014993321	64466	PT1383	WIRING HARNESS BLACK-OUT.....	1
7	PFOZZ	6150014993323	64466	63400-227	WIRING HARNESS MIDTURN ABS.....	1
8	PFOZZ	6150014993327	64466	52302-036	WIRING HARNESS PL-10 MARKER.....	2
9	PFOZZ	6150014993328	64466	82100-008	WIRING HARNESS LEAD PL 10, M871R USES 3, M871A1R & M871A2R USE 2.....	3
10	PFOZZ	6150014993329	64466	18125-400	WIRING HARNESS MAIN.....	1
11	PFOZZ	5325002791248	96906	MS35489-103	GROMMET, NONMETALLIC CLEARANCE AND ABS LIGHT WIRING.....	11
12	PFOZZ	5325002900074	96906	MS35489-109	GROMMET, NONMETALLIC.....	60
13	PFOZZ	5325014993362	0FBD6	50824060	GROMMET, NONMETALLIC.....	4

END OF FIGURE

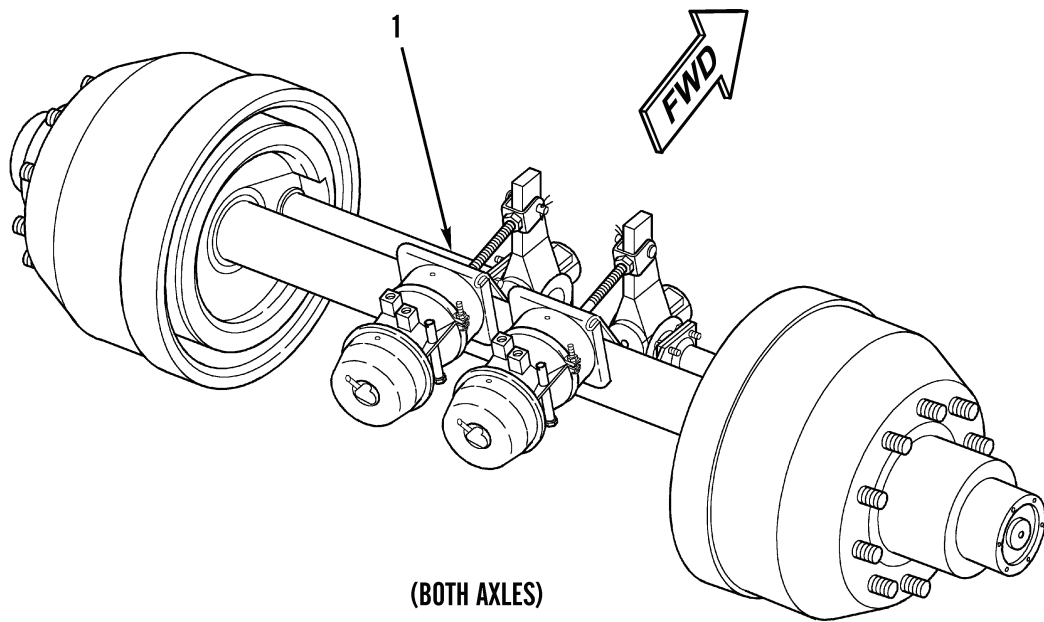

Figure 6. Axle Assembly.

(1) ITEM NO	(2) SMR CODE	(3) NSN	(4) CAGEC	(5) PART NUMBER	(6) DESCRIPTION AND USABLE ON CODES (UOC)	(7) QTY
-------------------	--------------------	------------	--------------	-----------------------	--	------------

GROUP 11 REAR AXLE

GROUP 1100 REAR AXLE ASSEMBLY

FIG. 6 AXLE ASSEMBLY

1	PBFFF	2520014995403	0FBD6	50045217	AXLE ASSEMBLY, AUTOM.....	2
---	-------	---------------	-------	----------	---------------------------	---

END OF FIGURE

11
12 THRU 16

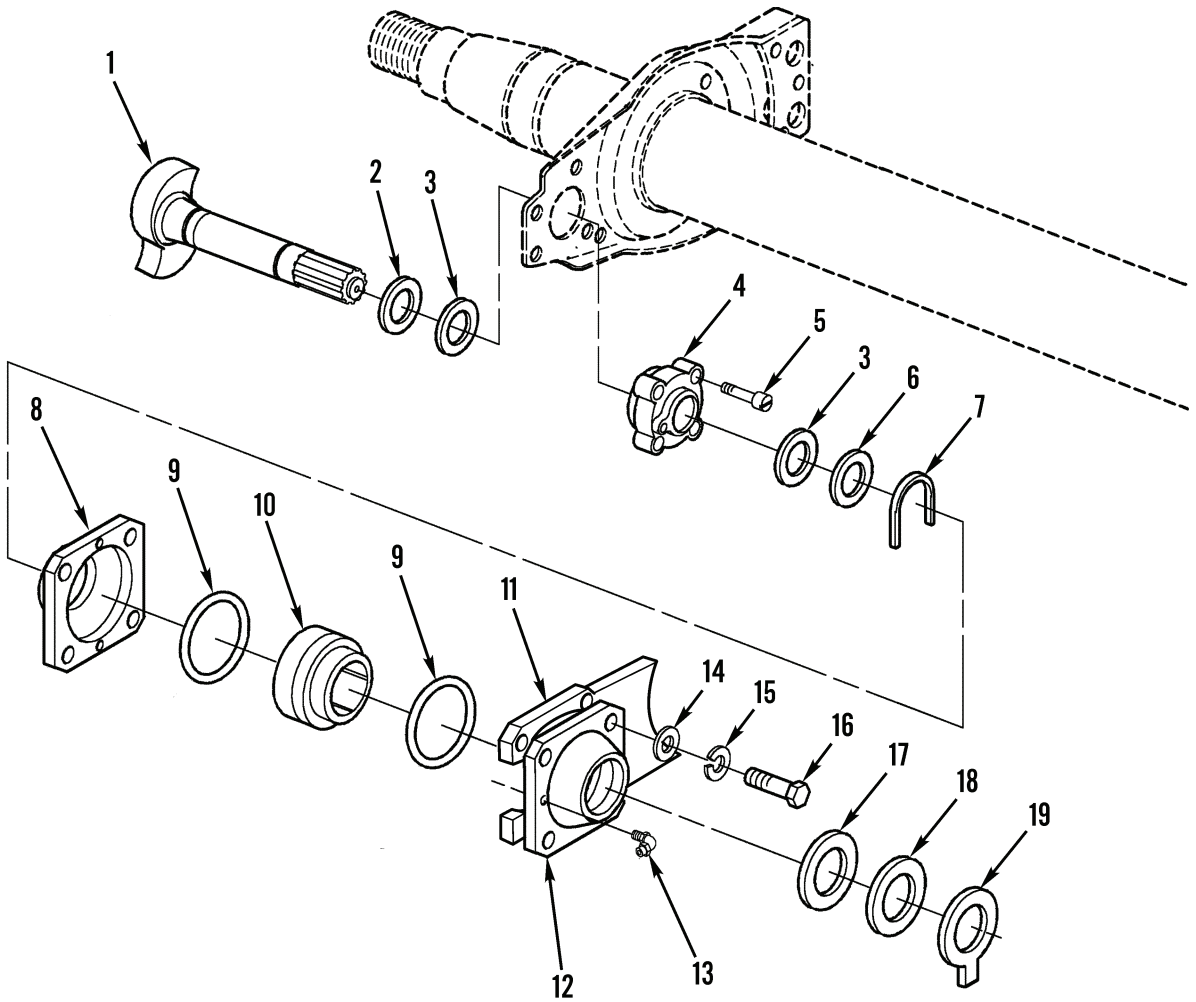

Figure 7. Brake Camshaft Components.

447-5007

(1) ITEM NO	(2) SMR CODE	(3) NSN	(4) CAGEC	(5) PART NUMBER	(6) DESCRIPTION AND USABLE ON CODES (UOC)	(7) QTY
GROUP 12 BRAKES						
GROUP 1202 SERVICE BRAKES						
FIG. 7 BRAKE CAMSHAFT COMPONENTS						
1	PFOZZ	2530014993135	78500	2210-D-6868	CAMSHAFT,ACTUATING, RH, Q-PLUS.....	2
1	PFOZZ	2530014993159	78500	2210-E-6869	CAMSHAFT,ACTUATING LH, Q-PLUS.....	2
2	PAOZZ	5310014993382	78500	1229-R-4100	WASHER,RECESSED PART OF KIT P/N KIT8078.....	1
3	PFOZZ	5330013286090	78500	1205-Q-2123	GASKET PART OF KIT P/N KIT8078.....	2
4	PFOZZ	2530013598091	3D6E9	A-3105-L-1078	RETAINER,ARM BUSHIN PART OF KIT P/N KIT8078.....	1
5	PAOZZ	5305013591367	78500	10-X-1421	SCREW,TAPPING PART OF KIT P/N KIT8078.....	4
6	PAOZZ	5310014993372	78500	1229-S-4101	WASHER,FLAT PART OF KIT P/N KIT8078.	1
7	PFOZZ	5325014993380	78500	1229-T-4102	RING,RETAINING PART OF KIT P/N KIT8078.....	1
8	PFOZZ	3120014993388	78500	1225-R-1058	BUSHING,SLEEVE.....	4
9	PFOZZ	5331002053583	78500	1205X726	O-RING.....	8
10	PFOZZ	3120015527425	78500	A-3105-K-219	BUSHING,SLEEVE.....	4
11	PFFFZ	2590015561271	78500	A-3299-T-5844	BRACKET,VEHICULAR C INCLUDES BRACKET AND BUSHING.....	2
12	PFOZZ	2530013118410	3D6E9	A3105-V-282	.PARTS KIT,BRAKE ADJ PART OF KIT P/N KIT8078.....	1
13	PFOZZ	4730014993385	3D6E9	2297-B-5046	.FITTING,LUBRICATION.....	4
14	PAOZZ	5310014993459	3D6E9	WA-36	.WASHER,FLAT.....	16
15	PAOZZ	5310002617340	78500	WA-16	.WASHER,LOCK.....	16
16	PAOZZ	5305013153563	78500	10-X-1348	.SCREW,TAPPING PART OF KIT P/N KIT8078.....	4
17	PFOZZ	5365007534865	78500	1229-J-868	SPACER,RING.....	4
18	PAOZZ	5310011335373	78500	1229-B-1848	WASHER,FLAT PART OF KIT P/N KIT8078.	2
19	PFOZZ	5325002045061	78500	1229-X-1116	RING,RETAINING PART OF KIT P/N KIT8078.....	1

END OF FIGURE

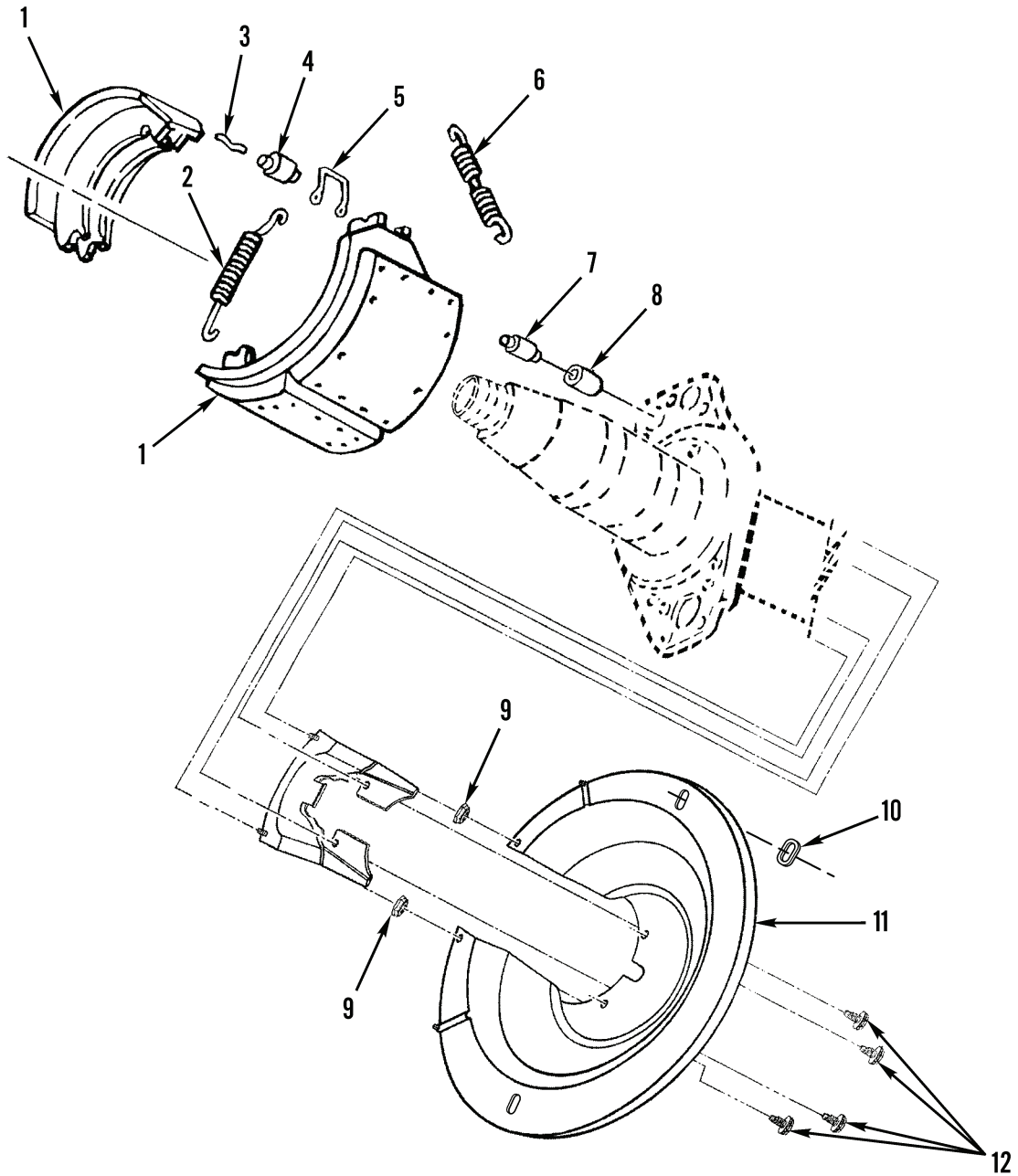

Figure 8. Service Brake Components.

447-5008

(1) ITEM NO	(2) SMR CODE	(3) NSN	(4) CAGEC	(5) PART NUMBER	(6) DESCRIPTION AND USABLE ON CODES (UOC)	(7) QTY
GROUP 1202 SERVICE BRAKES						
FIG. 8 SERVICE BRAKE COMPONENTS						
1	PFOZZ	2530014995407	78500	SR2024707QP	SHOE AND LINING ASS PER AXLE PART OF KIT P/N KSR2024707QP.....	4
2	PFOZZ	5360011581974	3D6E9	2258 Q 615S	SPRING, HELICAL, EXTE ORANGE, PER AXLE PART OF KIT P/N KSR2024707QP...	4
3	PFOZZ	5315007840637	78500	1218-G-85	PIN, RETURN SPRING PER AXLE PART OF KIT P/N KSR2024707QP.....	4
4	PFOZZ	3120003226430	78500	1779-R-18	ROLLER, LINEAR-ROTAR PER AXLE PART OF KIT P/N KSR2024707QP.....	4
5	PFOZZ	5340013284418	78500	N3105B210	CLIP, SPRING TENSION PER AXLE PART OF KIT P/N KSR2024707QP.....	4
6	PFOZZ	5360014993396	78500	2258-W-803	SPRING, HELICAL, COMP BLUE, PER AXLE PART OF KIT P/N KSR2024707QP.....	2
7	PFOZZ	5315011296898	78500	1259-N-274	PIN, SHOULDER, HEADLE PER AXLE PART OF KIT P/N KSR2024707QP.....	4
8	PFOZZ	3120002556042	78500	1225-B-496	BUSHING, ANCHOR PIN PER AXLE PART OF KIT P/N KSR2024707QP.....	4
9	PAOZZ	5310015561400	3DGR3	50995152	NUT, SELF-LOCKING, HE DUST SHIELD, PER AXLE.....	4
10	PFOZZ		78500	21220719	PLUG, DUST AND MOS 2 PER SHIELD, PER AXLE.....	4
11	PFOZZ	5340014993618	3D6E9	3264-A-1457	CAP, PROTECTIVE, DUST DUST SHIELD 2 PER AXLE.....	2
12	PAOZZ	5305015561411	3DGR3	50172106	SCREW, CAP, HEXAGON H 4 PER DUST SHIELD, PER AXLE.....	8

END OF FIGURE

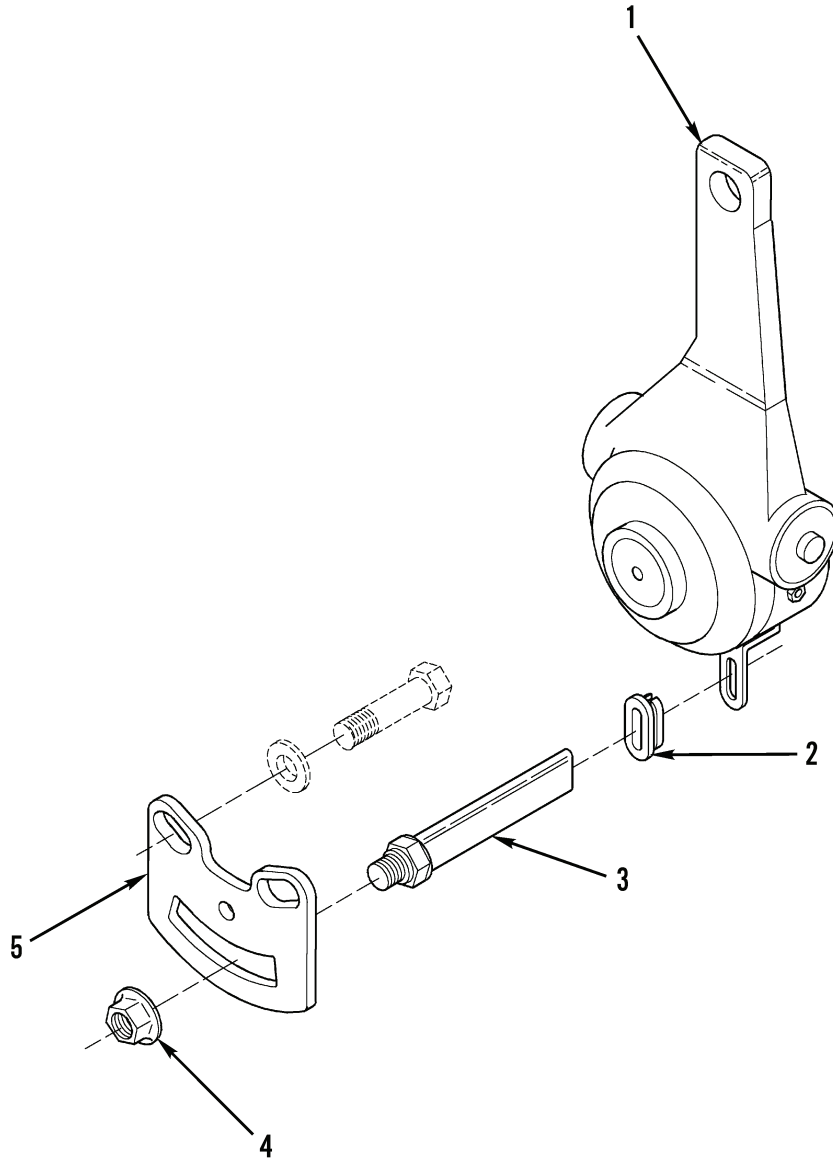

Figure 9. Slack Adjuster.

(1) ITEM NO	(2) SMR CODE	(3) NSN	(4) CAGEC	(5) PART NUMBER	(6) DESCRIPTION AND USABLE ON CODES (UOC)	(7) QTY
-------------------	--------------------	------------	--------------	-----------------------	--	------------

GROUP 1206 MECHANICAL BRAKE SYSTEM

FIG. 9 SLACK ADJUSTER

1	PFOZZ	2530014993399	78502	409-20002	ADJUSTER, SLACK, BRAK.....	2
2	PFOZZ	5365014993408	78502	452-10125	BUSHING, NONMETALLIC PART OF KIT P/N 427-10558.....	4
3	PFOZZ	5340014993404	06721	443-10318	STANDOFF, THREADED, S PART OF KIT P/N 427-10558.....	4
4	PAOZZ	5310014993438	78502	443-10204	NUT, PLAIN, EXTENDED PART OF KIT P/N 427-10563 PART OF KIT P/N 427-10558.	4
5	PFOZZ	5340014993405	78502	445-10467	BRACKET, MOUNTING PART OF KIT P/N 427 -10563 PART OF KIT P/N 427-10558....	4

END OF FIGURE

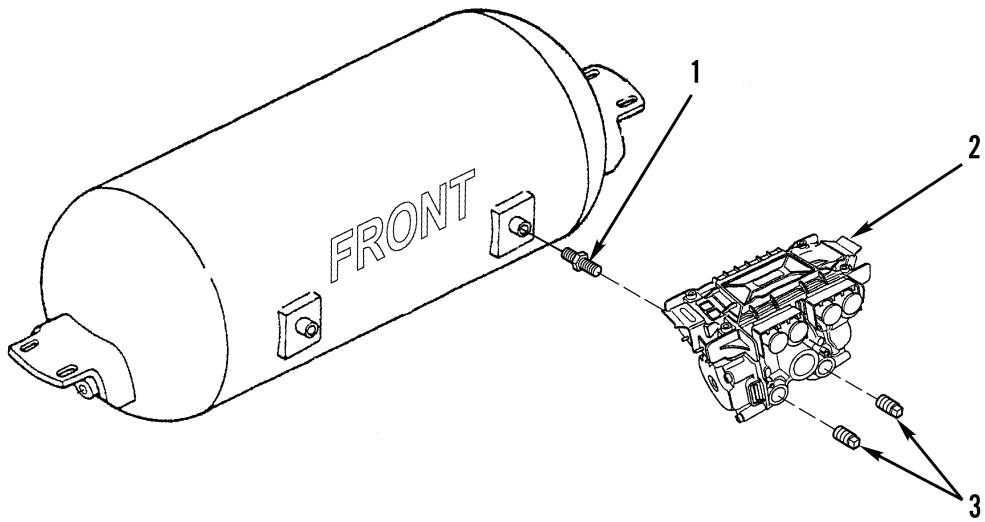

Figure 10. ECU/Valve Assembly.

447-5010

(1) ITEM NO	(2) SMR CODE	(3) NSN	(4) CAGEC	(5) PART NUMBER	(6) DESCRIPTION AND USABLE ON CODES (UOC)	(7) QTY
-------------------	--------------------	------------	--------------	-----------------------	--	------------

GROUP 1207 ELECTRICAL BRAKE SYSTEM

FIG. 10 ECU/VALVE ASSEMBLY

1	PFOZZ	4730014993406	3D6E9	AMP43726	NIPPLE, PIPE.....	1
2	PFOZZ	4810014993407	78500	S4005001030	VALVE ASSEMBLY ECU.....	1
3	PFOZZ	4730014994270	0FBD6	51205007	PLUG, PIPE 3/8" DIA.....	14

END OF FIGURE

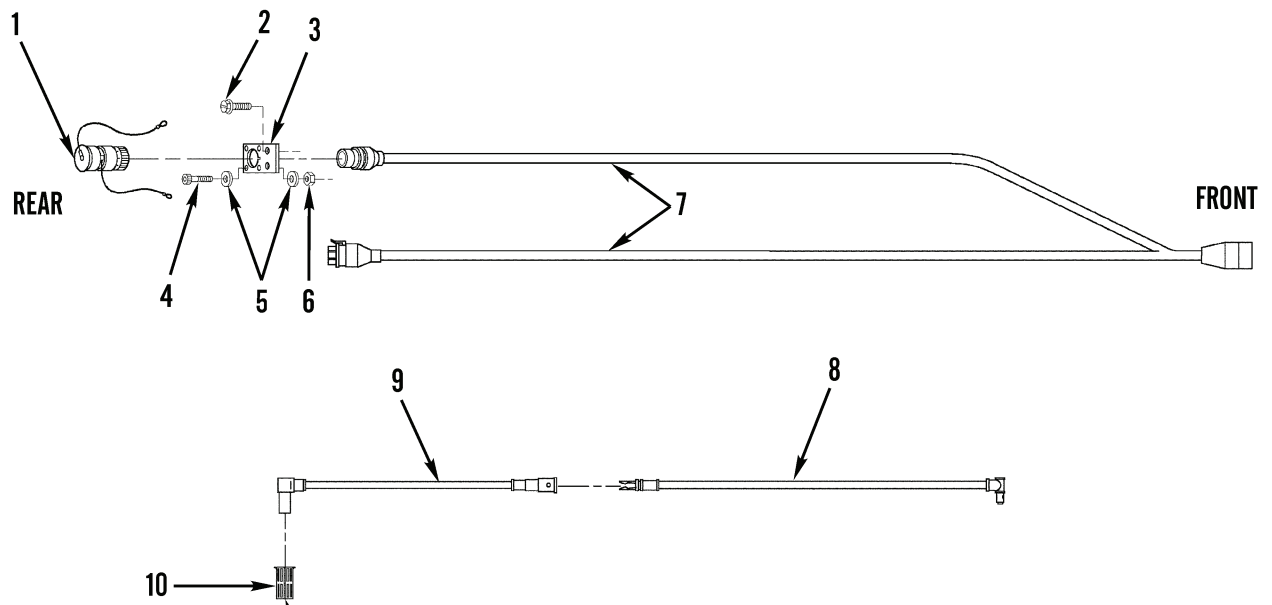

Figure 11. ABS Brake Power Harness and Sensor.

(1) ITEM NO	(2) SMR CODE	(3) NSN	(4) CAGEC	(5) PART NUMBER	(6) DESCRIPTION AND USABLE ON CODES (UOC)	(7) QTY
-------------------	--------------------	------------	--------------	-----------------------	--	------------

GROUP 1207 ELECTRICAL BRAKE SYSTEM

FIG. 11 ABS BRAKE POWER HARNESS
AND SENSOR

1	PFOZZ	5935014806241	78500	S2237-Z-1222	CONNECTOR, RECEPTACL BLINK CODE CONNECTOR.....	1
2	PAOZZ	5305014995551	0FBD6	52100010	SCREW, TAPPING 0.25 X 0.75.....	2
3	PFOZZ	2590015222672	78500	S3155-L-1234	BRACKET, VEHICULAR C.....	1
4	PAOZZ	5305015514703	39428	92196A130	SCREW, CAP, SOCKET HE #5-40.....	4
5	PAOZZ	5310015527435	39428	92141A006	WASHER, FLAT #5.....	8
6	PAOZZ	5310000458839	39428	91839A006	NUT, SELF-LOCKING, HE.....	4
7	PFOZZ	6150014993397	78500	S4493641530	CABLE ASSEMBLY, SPEC.....	1
8	PFOZZ	2530014993170	78500	S4497130300	SENSOR, ANTI-LOCK BR.....	4
9	PFOZZ	2530997823392	U6718	441 032 8080	SENSOR, ANTI-LOCK BR.....	2
10	PFOZZ	5340014993481	78500	S8997598154	CLIP, SPRING TENSION.....	2

END OF FIGURE

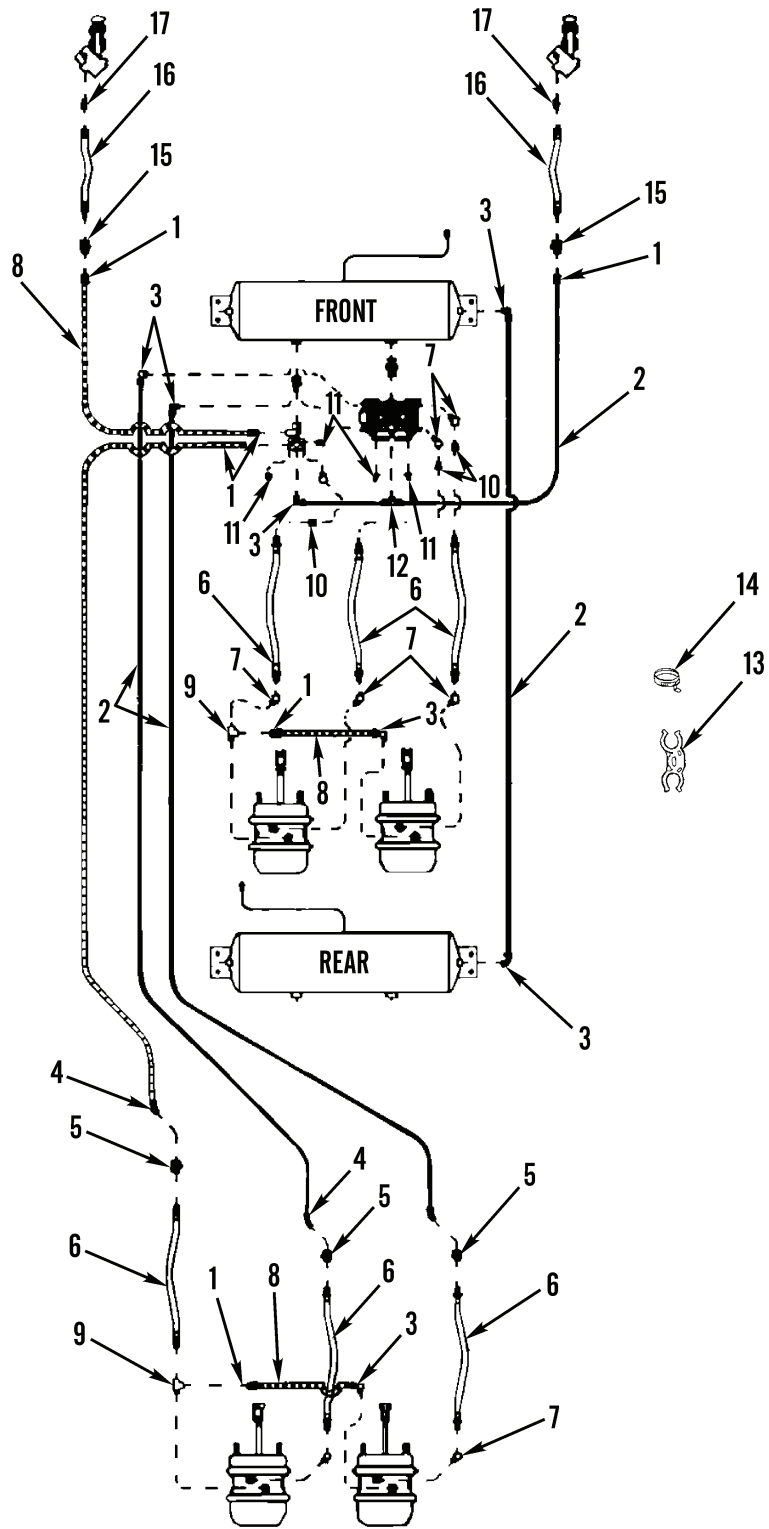

Figure 12. Air Lines and Fittings.

(1) ITEM NO	(2) SMR CODE	(3) NSN	(4) CAGEC	(5) PART NUMBER	(6) DESCRIPTION AND USABLE ON CODES (UOC)	(7) QTY
GROUP 1208 AIR BRAKE SYSTEM						
FIG. 12 AIR LINES AND FITTINGS						
1	PFOZZ	4730010969128	93061	68NTA-6-6	ADAPTER, STRAIGHT, PI.....	6
2	MOOZZ		61424	PFT-6B-BLU-AR	TUBING, NONMETALLIC 3/8" CUT TO FIT, MAKE FROM TUBE NSN 4720-01-287-9322	1
3	PFOZZ	5935012241226	98278	MCDM1-31SS	CONNECTOR, RECEPACL.....	8
4	PFOZZ	4730013659072	93061	VS279NTA-6-4	ELBOW, PIPE TO TUBE.....	3
5	PFOZZ	4730011643365	93061	207ACBH-4	COUPLING, PIPE.....	3
					UOC:SCB, SKB	
5	PFOZZ	4730015561426	3DGR3	50104002	ADAPTER, STRAIGHT, TU.....	2
					UOC:SJB	
6	PFOZZ	4720014993490	0FBD6	50866003	HOSE ASSEMBLY, NONME INCLUDES BUSHING PN 209P-6-4 (93061).....	6
7	PFOZZ	4730002778257	81343	6-6 130339B	ELBOW, PIPE.....	7
8	MOOZZ		61424	PFT-6B-RED-AR	HOSE, NONMETALLIC 3/8" CUT TO FIT, MAKE FROM TUBE NSN 4720-01-287-9313.	1
9	PFOZZ	4730004697797	93061	2225P-6	TEE, PIPE.....	2
10	PFOZZ	4730002026491	93061	209P-6-4	BUSHING, PIPE.....	3
11	PFOZZ	4730014994270	0FBD6	51205007	PLUG, PIPE.....	4
12	PFOZZ	4730012831877	93061	VS272NTA-6-6	TEE, PIPE TO TUBE.....	2
13	PFOZZ	5340014993717	0FBD6	50491010	CLIP, RETAINING.....	12
14	PFOZZ	4730014993709	93061	50487001	CLAMP, HOSE.....	4
15	PFOZZ	4730015561425	3DGR3	50104001	ADAPTER, STRAIGHT, TU 1/4-18 NPTF ID X 3/4-16 UNF OD.....	5
16	PFOZZ	4720015562134	3DGR3	50866009	HOSE ASSEMBLY, NONME 3/8".....	2
17	PFOZZ	4730015561420	3DGR3	50501006	ADAPTER, STRAIGHT, PI 3/8' TUBE.....	2
					UOC:SKB	
17	PFOZZ	4730015561422	3DGR3	50720025	ADAPTER, STRAIGHT, PI 3/8' TUBE 45 DEG.....	2
					UOC:SJB	
17	PFOZZ	4730010969128	93061	68NTA-6-6	ADAPTER, STRAIGHT, PI 3/8' TUBE.....	2
					UOC:SCB	

END OF FIGURE

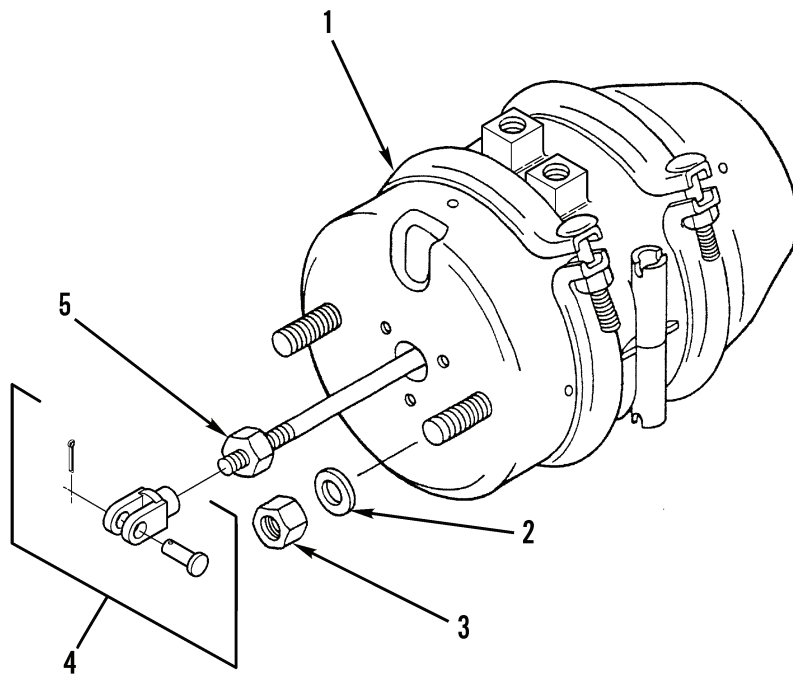

Figure 13. Air Brake Chamber.

(1) ITEM NO	(2) SMR CODE	(3) NSN	(4) CAGEC	(5) PART NUMBER	(6) DESCRIPTION AND USABLE ON CODES (UOC)	(7) QTY
-------------------	--------------------	------------	--------------	-----------------------	--	------------

GROUP 1208 AIR BRAKE SYSTEM

FIG. 13 AIR BRAKE CHAMBER

1	PFOZZ	2530015042552	06721	166407	CHAMBER,AIR BRAKE LONG STROKE.....	2
2	PAOZZ	5310014995412	06721	9999093	WASHER, FLAT.....	8
3	PAOZZ	5310014995416	0FBD6	50981049	NUT, SELF-LOCKING, AS 5/8-11.....	2
4	PFOZZ	2520014993439	0FBD6	52125333	UNIVERSAL JOINT, VEH.....	4
5	PAOZZ	5310008807744	96906	MS51967-5	NUT, PLAIN, HEXAGON 5/8-18.....	4

END OF FIGURE

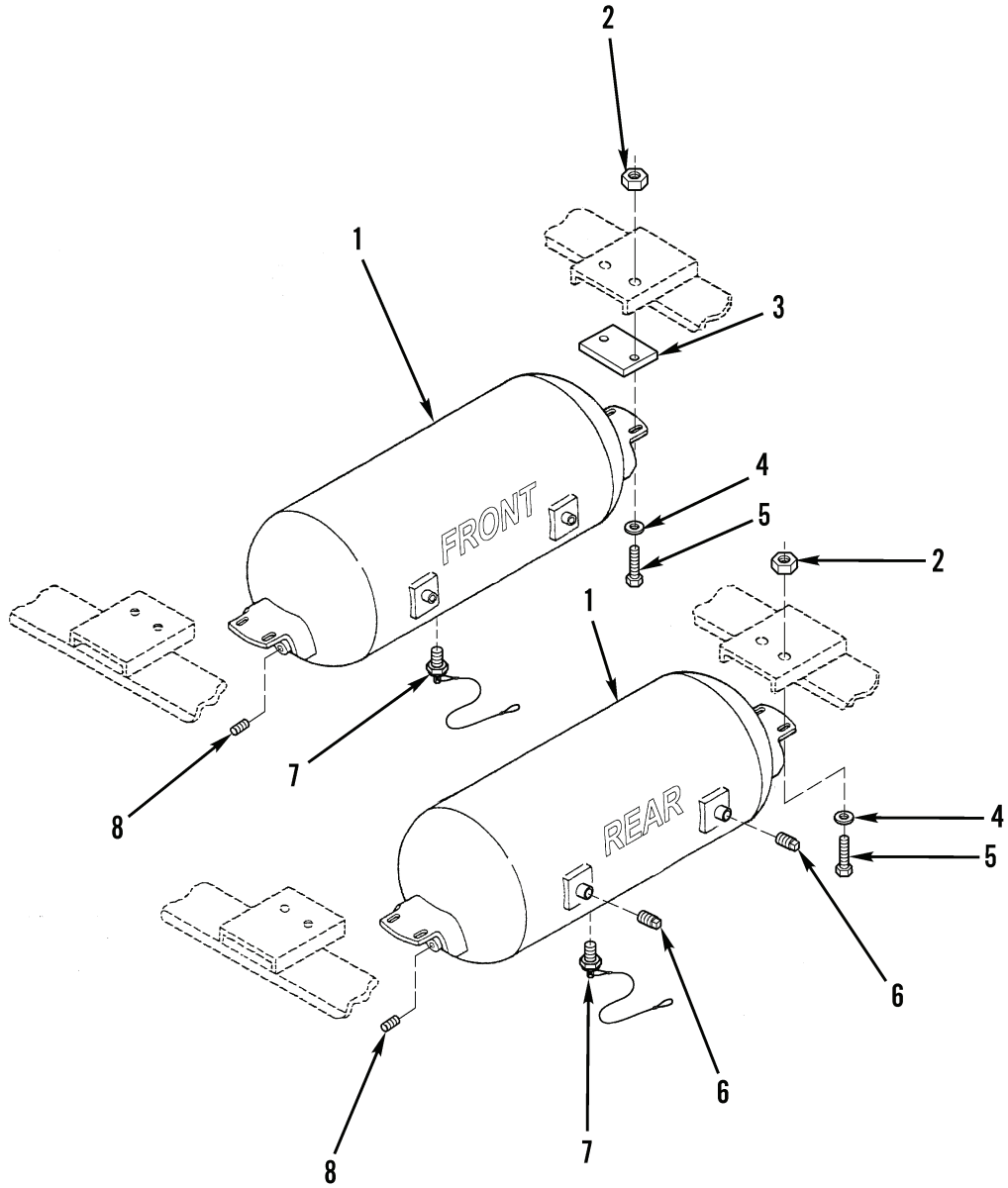

Figure 14. Air Reservoirs.

(1) ITEM NO	(2) SMR CODE	(3) NSN	(4) CAGEC	(5) PART NUMBER	(6) DESCRIPTION AND USABLE ON CODES (UOC)	(7) QTY
GROUP 1208 AIR BRAKE SYSTEM						
FIG. 14 AIR RESERVOIRS						
1	PFOZZ	2530014993629	3DGR3	3229	TANK, PRESSURE FRONT PRIMARY AND REAR RESERVE.....	2
2	PAOZZ	5310014993456	0FBD6	50995054	NUT, SELF-LOCKING, HE.....	8
3	PFOZZ	9320014993458	0FBD6	51029007	RUBBER SHEET, SOLID.....	4
4	PAOZZ	5310014993461	0FBD6	55752005	WASHER, FLAT.....	8
5	PAOZZ	5305014993465	0FBD6	50172008	SCREW, CAP, HEXAGON H.....	8
6	PFOZZ	4730014993360	0FBD6	51205015	PLUG, PIPE 3/4".....	2
7	PFOZZ	4820014993653	0N972	401095	COCK, DRAIN.....	2
8	PFOZZ	4730014994270	0FBD6	51205007	PLUG, PIPE 3/8 SQ. HEAD.....	2

END OF FIGURE

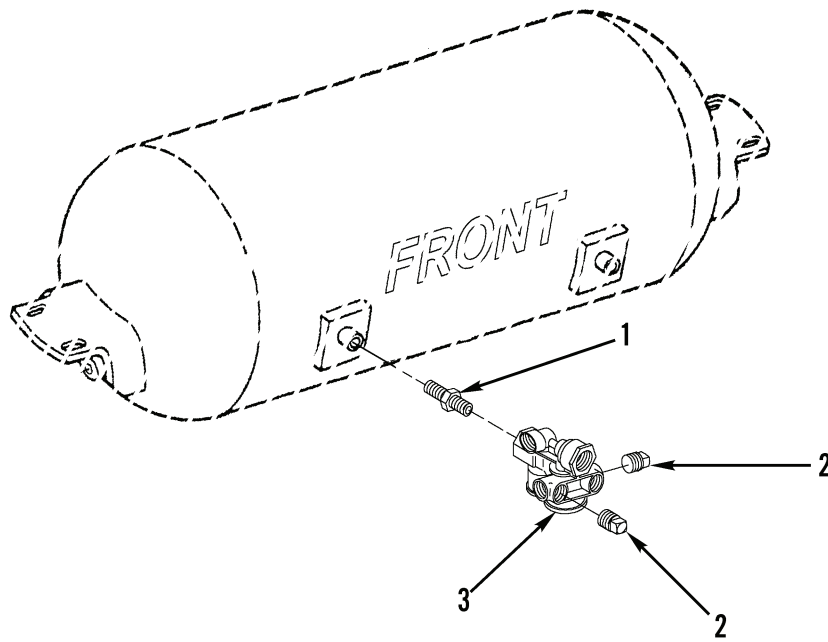

Figure 15. Air Brake Chamber Control Valve.

447-5015

(1) ITEM NO	(2) SMR CODE	(3) NSN	(4) CAGEC	(5) PART NUMBER	(6) DESCRIPTION AND USABLE ON CODES (UOC)	(7) QTY
-------------------	--------------------	------------	--------------	-----------------------	--	------------

GROUP 1208 AIR BRAKE SYSTEM

FIG. 15 AIR BRAKE CHAMBER CONTROL VALVE

1	PFOZZ	4730014993663	3D6E9	50979015	REDUCER, PIPE 1/2" TO 3/4".....	1
2	PFOZZ	4730014994270	0FBD6	51205007	PLUG, PIPE 3/8".....	2
3	PFOZZ	4820014978729	10125	110500	VALVE, CHECK.....	1

END OF FIGURE

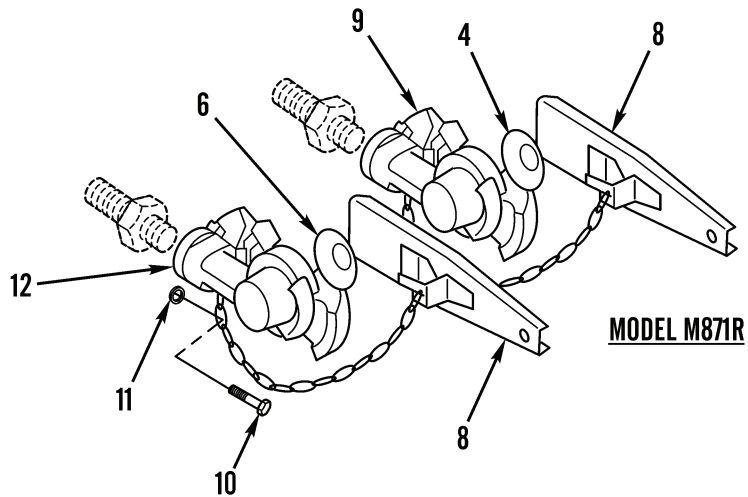
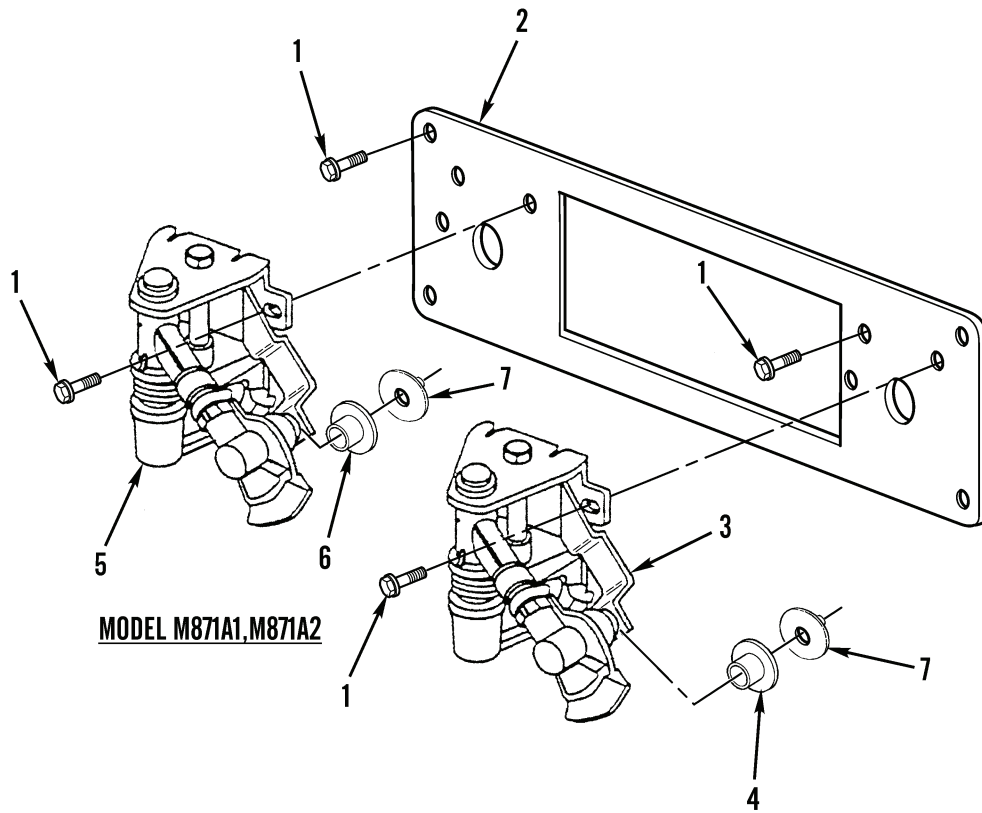

Figure 16. Gladhands.

(1) ITEM NO	(2) SMR CODE	(3) NSN	(4) CAGEC	(5) PART NUMBER	(6) DESCRIPTION AND USABLE ON CODES (UOC)	(7) QTY
GROUP 1208 AIR BRAKE SYSTEM						
FIG. 16 GLADHANDS						
1	PAOZZ	5305014995551	0FBD6	52100010	SCREW, TAPPING..... UOC:SKB	14
2	PFOZZ	5340015578520	3DGR3	65340002	PLATE, MOUNTING..... UOC:SKB	1
3	PFOOZ	4730014993471	0N972	441105	CONNECTOR, SWIVEL FL EMERGENCY..... UOC:SCB, SKB	1
4	PFOZZ	5330015048614	45152	4HA892	SEAL, PLAIN RED.....	1
5	PFOOZ	4730014993471	0N972	441105	CONNECTOR, SWIVEL FL SERVICE..... UOC:SCB, SKB	1
6	PFOZZ	5330015048610	45152	4HA891	SEAL, PLAIN BLUE.....	1
7	PFOZZ	5340015518607	0N972	441743	PACKING, PREFORMED..... UOC:SKB	2
8	PFOZZ	2530015561664	3DGR3	50823046	DUMMY COUPLING, AUTO..... UOC:SJB	2
9	PFOZZ	4730015571926	3DGR3	50823045	COUPLING HALF, QUICK EMERGENCY, STRAIGHT..... UOC:SJB	1
10	PAOZZ	5305014995551	0FBD6	52100010	SCREW, TAPPING..... UOC:SJB	2
11	PAOZZ	5310015561277	3DGR3	50823047	WASHER, FLAT..... UOC:SJB	2
12	PFOZZ	4730015561415	3DGR3	50823044	COUPLING HALF, QUICK SERVICE, STRAIGHT..... UOC:SJB	1

END OF FIGURE

2
3 THRU 7

11
12 THRU 14

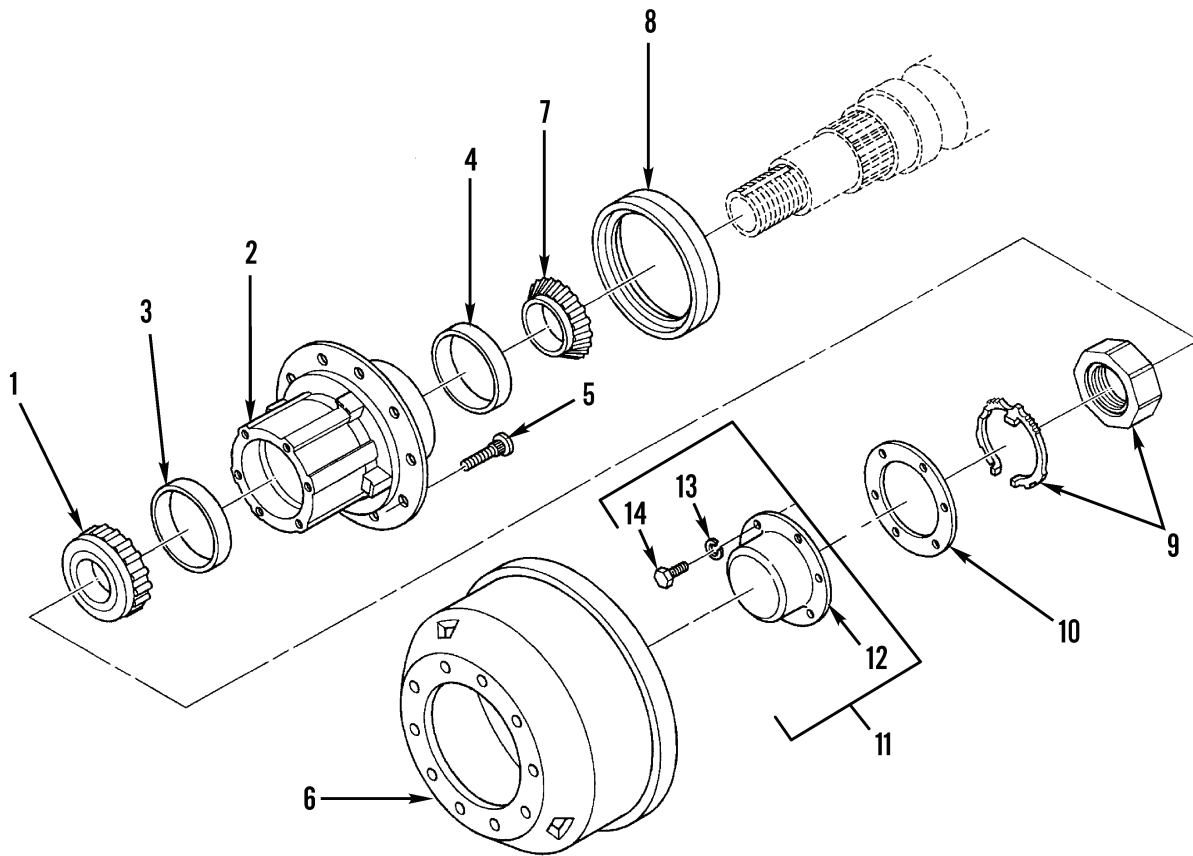

Figure 17. Hub and Drum.

447-5017

(1) ITEM NO	(2) SMR CODE	(3) NSN	(4) CAGEC	(5) PART NUMBER	(6) DESCRIPTION AND USABLE ON CODES (UOC)	(7) QTY
GROUP 13 WHEEL AND TRACKS						
GROUP 1311 WHEEL ASSEMBLY						
FIG. 17 HUB AND DRUM						
1	PFOZZ	3110002938998	60038	HM212049	CONE AND ROLLERS,TA OUTER.....	2
2	PFOZZ	2530014993476	18889	20231UH3T	HUB,WHEEL,VEHICULAR INCLUDES TONE RING, (10) R/H STUDS, INNER & OUTER BEARING CUPS.....	4
3	PFOZZ	3110002938997	60038	HM212011	.CUP,TAPERED ROLLER OUTER.....	1
4	PFOZZ	3110006180249	81348	FF-B-171/01-652	.CUP,TAPERED ROLLER INNER.....	1
5	PFOZZ	5307014401364	18889	101162	.STUD,PLAIN ALL RH.....	10
6	PFOZZ	2530014499475	18889	66884	.BRAKE DRUM.....	1
7	PFOZZ	3110006180248	60038	HM218248	.CONE AND ROLLERS,TA.....	2
8	PFOZZ	5330010902107	01212	B370025BG2	SEAL,PLAIN.....	2
9	PFOZZ	5310014995416	0FBD6	50981049	NUT,SELF-LOCKING,AS PRO-TORQ WITH KEEPER, 2 PER AXLE.....	4
10	PFOZZ	5330014993487	80201	453795	GASKET.....	4
11	PFOOO	2530014995421	80201	C/R1343	HUB CAP,WHEEL INCLUDES HUBCAP, (6) BOLTS & WASHERS.....	2
12	XAOZZ		80201	CR453969	.HUBCAP.....	4
13	PAOZZ	5306002264827	80204	B1821BH031C100N	.BOLT,MACHINE 5/16-18 X 1.00".....	6
14	PAOZZ	5310004079566	80205	MS35338-45	.WASHER,LOCK 5/16".....	6

END OF FIGURE

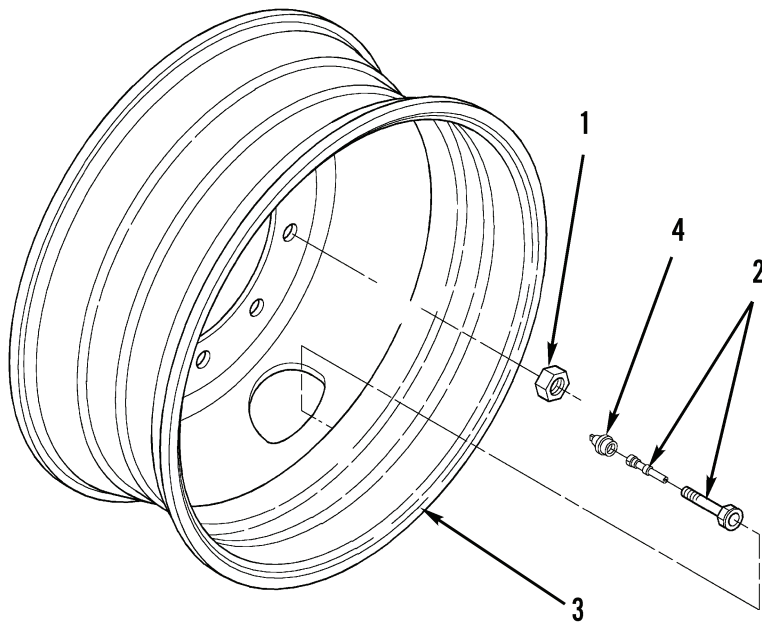

Figure 18. Wheel Assembly.

(1) ITEM NO	(2) SMR CODE	(3) NSN	(4) CAGEC	(5) PART NUMBER	(6) DESCRIPTION AND USABLE ON CODES (UOC)	(7) QTY
-------------------	--------------------	------------	--------------	-----------------------	--	------------

GROUP 1311 WHEEL ASSEMBLY

FIG. 18 WHEEL ASSEMBLY

1	PFOZZ	5310014993489	0FBD6	50990007	NUT,PLAIN,HEXAGON FLANGE NUT, RH...	40
2	PFOZZ	2640005552823	58536	TY-II/CL2/TR-572	VALVE,PNEUMATIC TIR.....	9
3	PFOFF	2530014419700	73195	28408	WHEEL,PNEUMATIC TIR ONE PIECE, HUB PILOTED, INCLUDES TIRE PN: 95283 (12195).....	9
4	PFOZZ	2640010982029	63900	A-100-VC-8	CAP,PNEUMATIC VALVE.....	9

END OF FIGURE

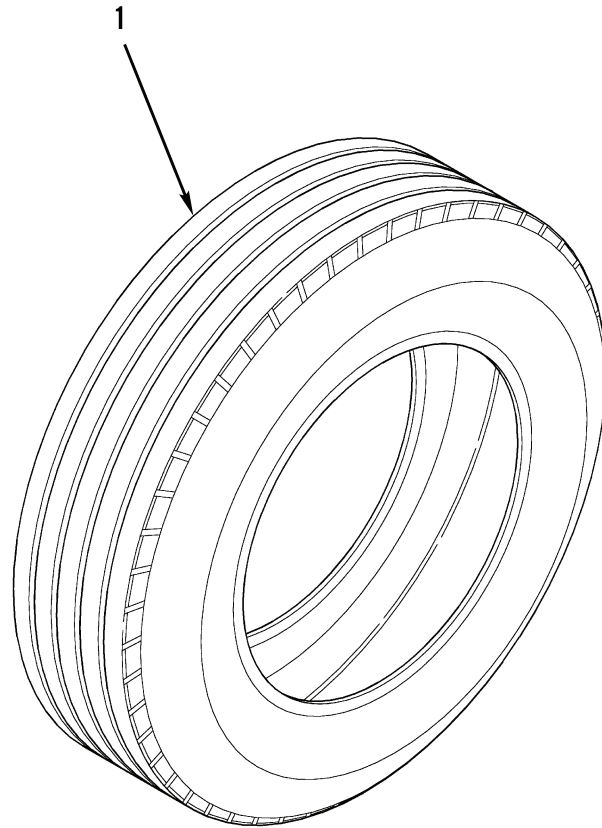

Figure 19. Tire.

(1) ITEM NO	(2) SMR CODE	(3) NSN	(4) CAGEC	(5) PART NUMBER	(6) DESCRIPTION AND USABLE ON CODES (UOC)	(7) QTY
-------------------	--------------------	------------	--------------	-----------------------	--	------------

GROUP 1313 TIRES, TUBES, TIRE CHAINS

FIG. 19 TIRE

1 PCOZZ 2610015588770 12195 95283

TIRE, PNEUMATIC, VEHI RADIAL, 9
 TUBELESS 11R22.5XZE*LRH, INCLUDES
 WHEEL PN: 28408(73195).....

END OF FIGURE

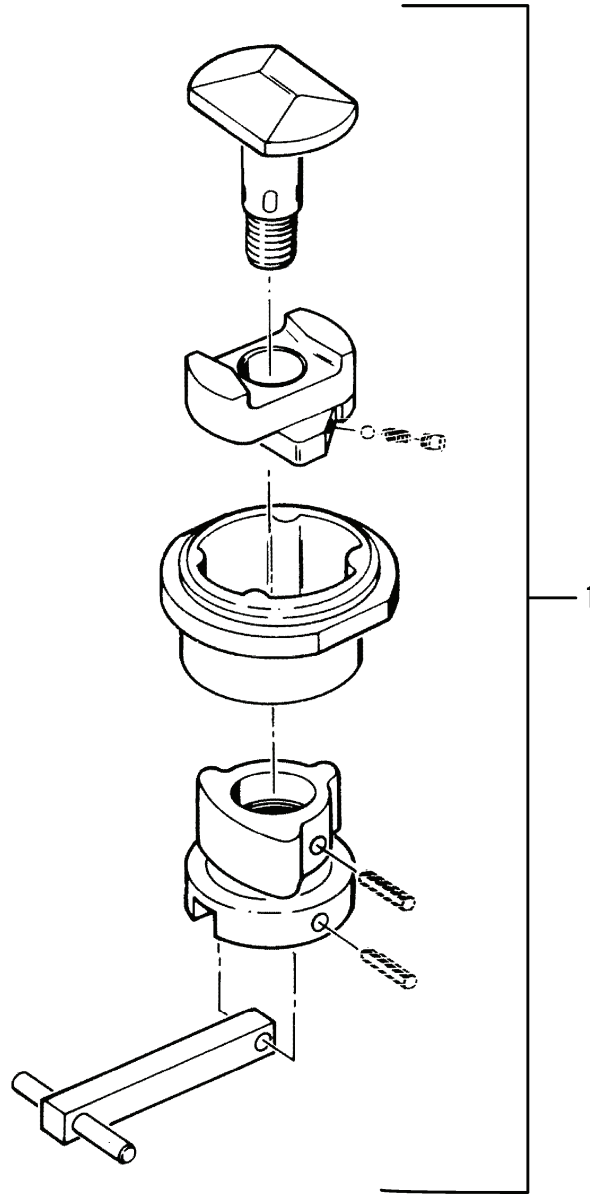

MODELS
M871R
M871A1R

Figure 20. Retractable Twist Lock (Sheet 1 of 2).

2	3
3 THRU 6	4 AND 5

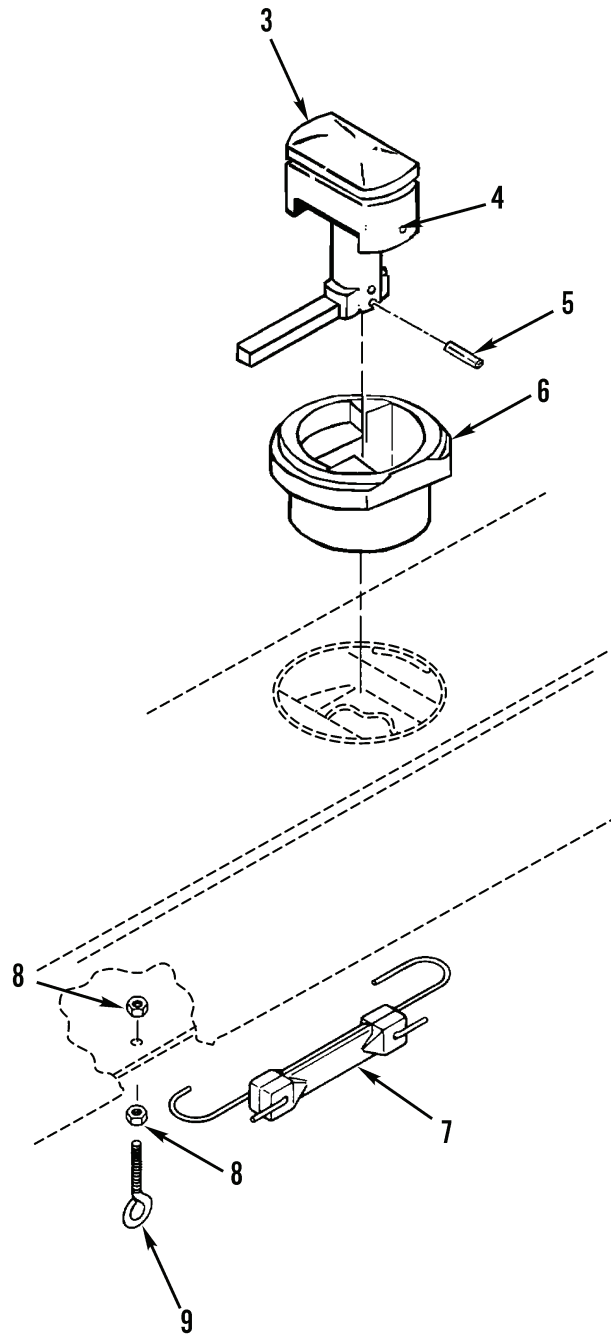

MODEL
M871A2R

Figure 20. Retractable Twist Lock (Sheet 2 of 2).

(1) ITEM NO	(2) SMR CODE	(3) NSN	(4) CAGEC	(5) PART NUMBER	(6) DESCRIPTION AND USABLE ON CODES (UOC)	(7) QTY
GROUP 15 FRAME, TOWING ATTACHMENTS, DRAWBARS, AND ARTICULATION SYSTEMS						
GROUP 1501 FRAME ASSEMBLY						
FIG. 20 RETRACTABLE TWIST LOCK						
1	PFOZZ	5340012096524	65059	78038-1	LOCK,RIM TWISTLOCK ASSY..... UOC:SCB,SJB	4
2	PFFFF	5325015149957	94658	F804-1-3	FASTENER ASSEMBLY,T TWISTLOCK ASSY, ISO W/SOCKET (CUP)..... UOC:SKB	4
3	PFOZZ	2510014994290	94658	F804-1-4	.KIT,TWISTLOCK REPAI WITH HANDLE... UOC:SKB	1
4	PFOZZ	4730000504203	81343	AS15001-1	..FITTING,LUBRICATION..... UOC:SKB	1
5	PFOZZ	2590012600219	94658	RK804-1A	..TWISTLOCK,CONE,KIT INCLUDES TWISTLOCK CONE KIT, HANDLE,CONE, LOCATING TRUNK,ASSORTED PINS..... UOC:SKB	1
6	XDFZZ		94658	PH2969-1	.CUP SOCKET..... UOC:SKB	1
7	PAOZZ	5340013172657	1F926	6	STRAP,ELASTIC..... UOC:SKB	4
8	PAOZZ	5310012517570	39428	90480A011	NUT,PLAIN,HEXAGON..... UOC:SKB	8
9	PAOZZ	5306012229071	39428	9489T13	BOLT,EYE..... UOC:SKB	4

END OF FIGURE

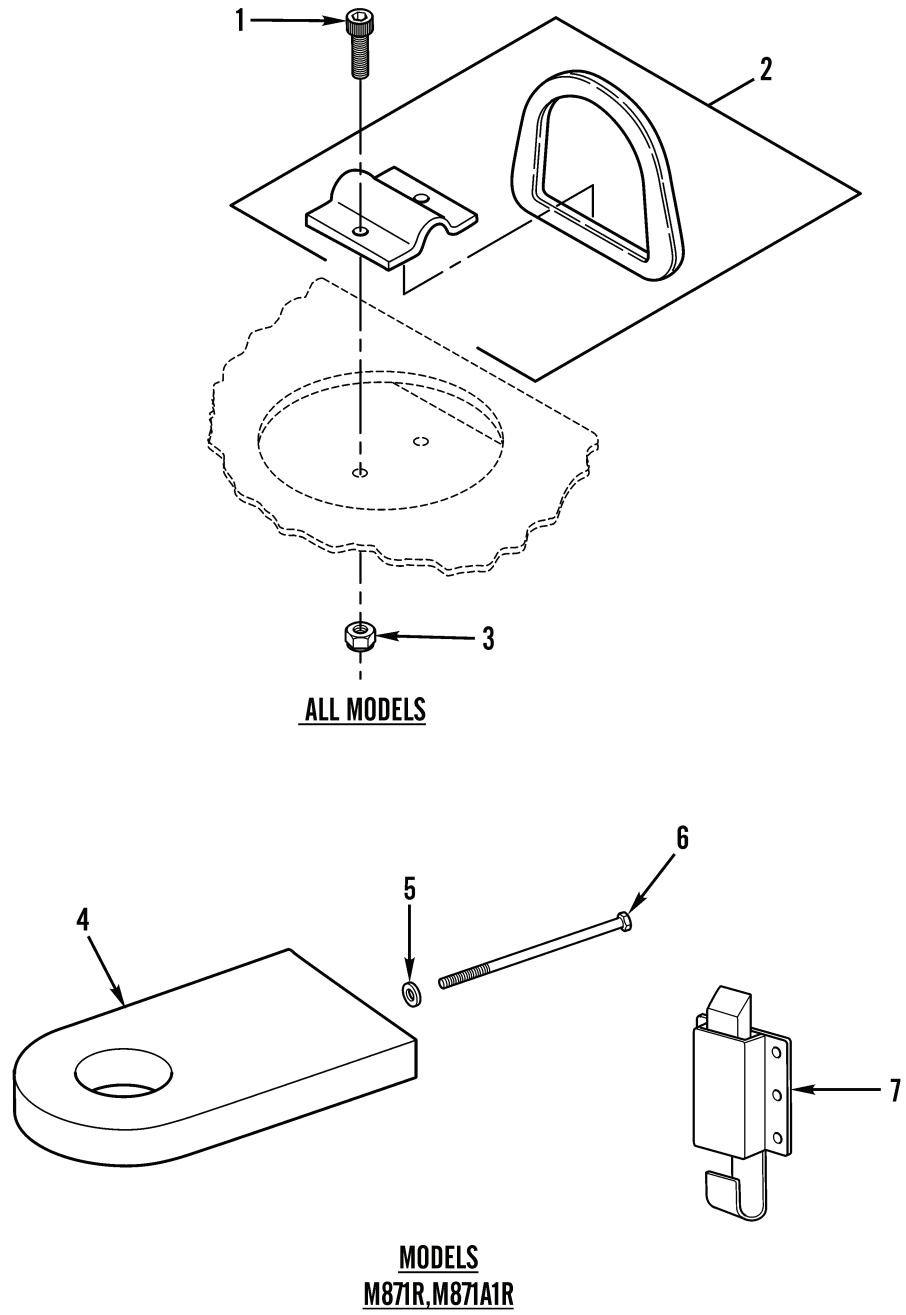
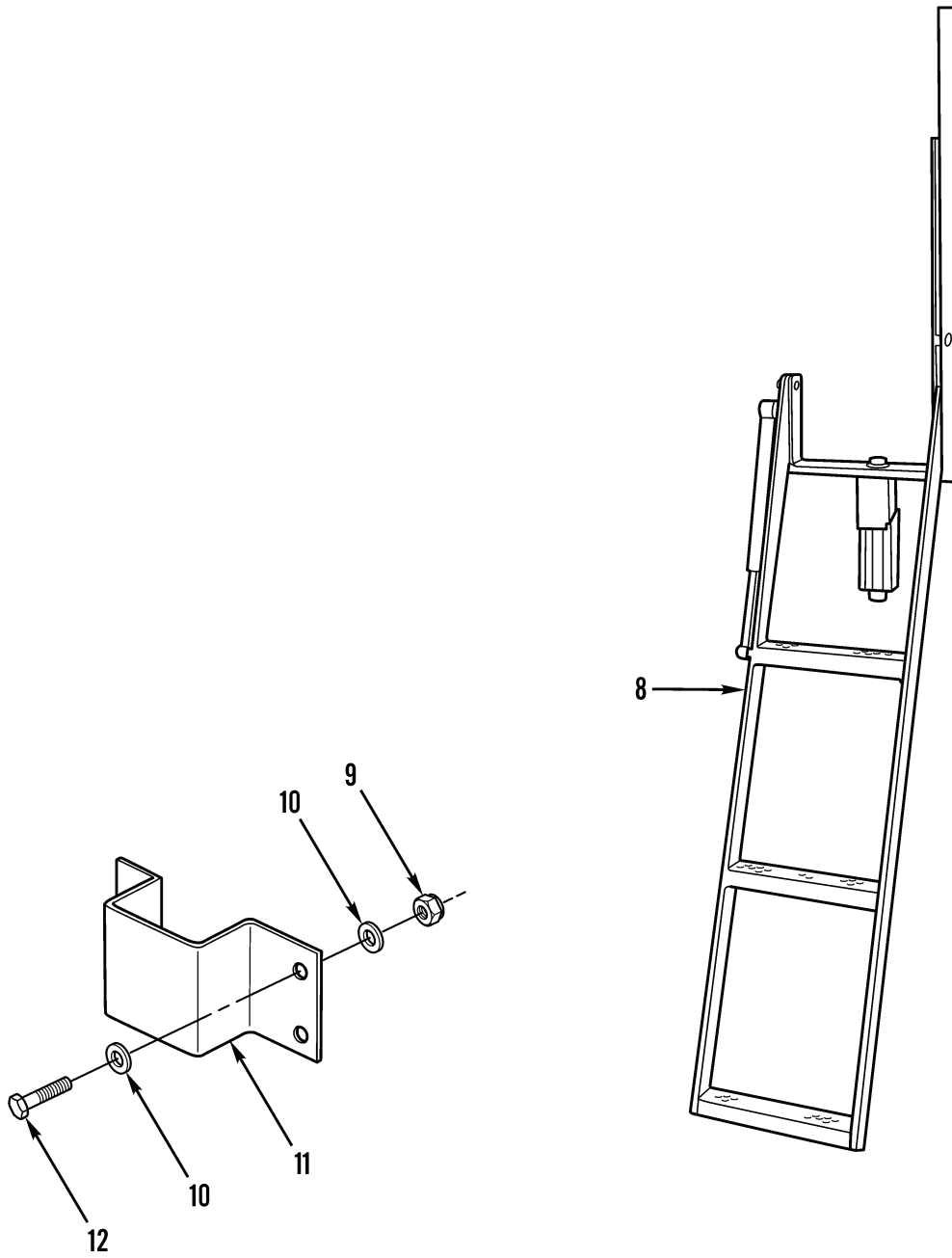
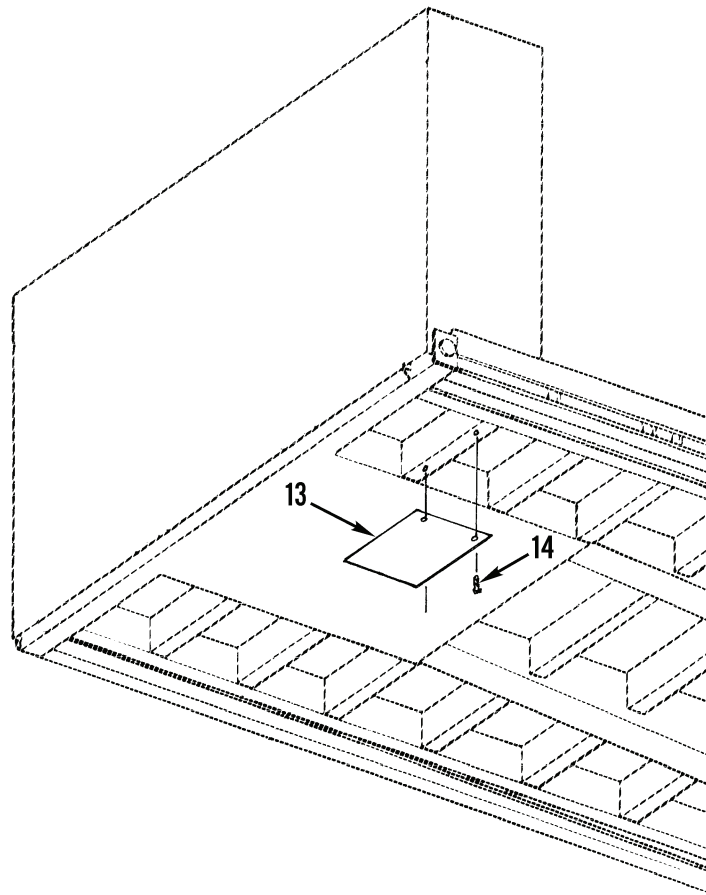

Figure 21. Lifting, Tiedown Ring, Ladder, Cover Plate, and Related Parts (Sheet 1 of 3).



447-5021-2

Figure 21. Lifting, Tiedown Ring, Ladder, Cover Plate, and Related Parts (Sheet 2 of 3).



MODEL
M871R

447-5021-3

Figure 21. Lifting, Tiedown Ring, Ladder, Cover Plate, and Related Parts (Sheet 3 of 3).

(1) ITEM NO	(2) SMR CODE	(3) NSN	(4) CAGEC	(5) PART NUMBER	(6) DESCRIPTION AND USABLE ON CODES (UOC)	(7) QTY
GROUP 1501 FRAME ASSEMBLY						
FIG. 21 LIFTING, TIEDOWN RING, LADDER, COVER PLATE, AND RELATED PARTS						
1	PAOZZ	5305014321763	39428	91251A628	SCREW,CAP, SOCKET HE 3/8-16 X 1.50".	2
2	PFOZZ	5365013146592	94658	F187-20-8	RING,DEE.....	10
3	PAOZZ	5310009359021	96906	MS51943-35	NUT,SELF-LOCKING,HE 3/8 IN.....	2
4	PFOZZ	5340012390890	66788	SAT-18315	PAD EYE.....	4
					UOC:SCB,SJB	
5	PAOZZ	5310000877493	96906	MS27183-13	WASHER, FLAT.....	4
					UOC:SCB,SJB	
6	PAOZZ	5305000712072	80204	B1821BH050C225N	SCREW,CAP,HEXAGON H.....	4
					UOC:SCB	
7	PFOZZ	5340013186775	06CB9	BF90M45XXZNXX	LOCK,FLUSH.....	4
					UOC:SCB	
8	PFOZZ	2541015314064	05SD1	2511	LADDER,VEHICLE BOAR.....	1
9	PAOZZ	5310004883889	96906	MS51943-39	NUT,SELF-LOCKING,HE.....	4
10	PAOZZ	5310000806004	96906	MS27183-14	WASHER, FLAT.....	8
11	PFOZZ	2590015328937	3DGR3	61251004	BRACKET,VEHICULAR C.....	1
12	PAOZZ	5305000712069	80204	B1821BH050C150N	SCREW,CAP,HEXAGON H.....	4
13	PFOZZ	5340015561428	3DGR3	64014008	COVER,ACCESS.....	1
					UOC:SJB	
14	PAOZZ	5305014995551	0FBD6	52100010	SCREW,TAPPING.....	2
					UOC:SJB	

END OF FIGURE

5
6 THRU 10

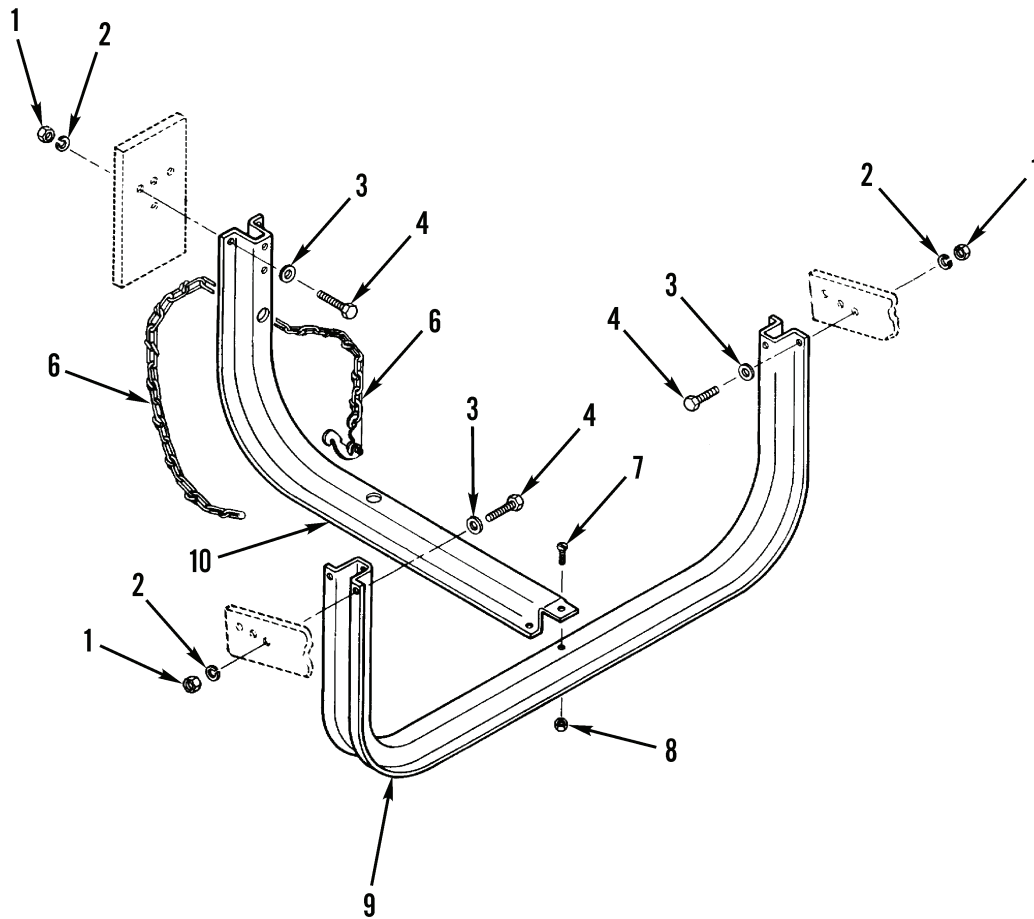

Figure 22. Spare Tire Carrier.

447-5022

(1) ITEM NO	(2) SMR CODE	(3) NSN	(4) CAGEC	(5) PART NUMBER	(6) DESCRIPTION AND USABLE ON CODES (UOC)	(7) QTY
GROUP 1504 SPARE WHEEL CARRIER AND TIRE LOCK						
FIG. 22 SPARE TIRE CARRIER						
1	PAOZZ	5310009359021	96906	MS51943-35	NUT, SELF-LOCKING, HE 3/8-13.....	9
2	PAOZZ	5310006379541	00198	132661	WASHER, LOCK 3/8".....	9
3	PAOZZ	5310000806004	96906	MS27183-14	WASHER, FLAT 3/8".....	9
4	PAOZZ	5305007252317	80204	B1821BH038C150N	SCREW, CAP, HEXAGON H 3/8-16 X 1.50".	6
5	PFOOO	2590012416060	99411	TS0002	CARRIER ASSEMBLY, TI.....	1
6	PFOZZ	2590013152610	99411	CP3473	.PARTS KIT, TIRE CARR 3/16 X 1 5/8" X 5.5FT LONG.....	2
7	PAOZZ	5305005434372	80204	B1821BH038C075N	.SCREW, CAP, HEXAGON H 3/8-16 X 3/4".	3
8	PAOZZ	5310009359021	96906	MS51943-35	.NUT, SELF-LOCKING, HE 3/8-16".....	3
9	XAOZZ		99411	TS0013	.FRAME, U.....	1
10	XAOZZ		99411	CP0540	.FRAM, REAR.....	1

END OF FIGURE

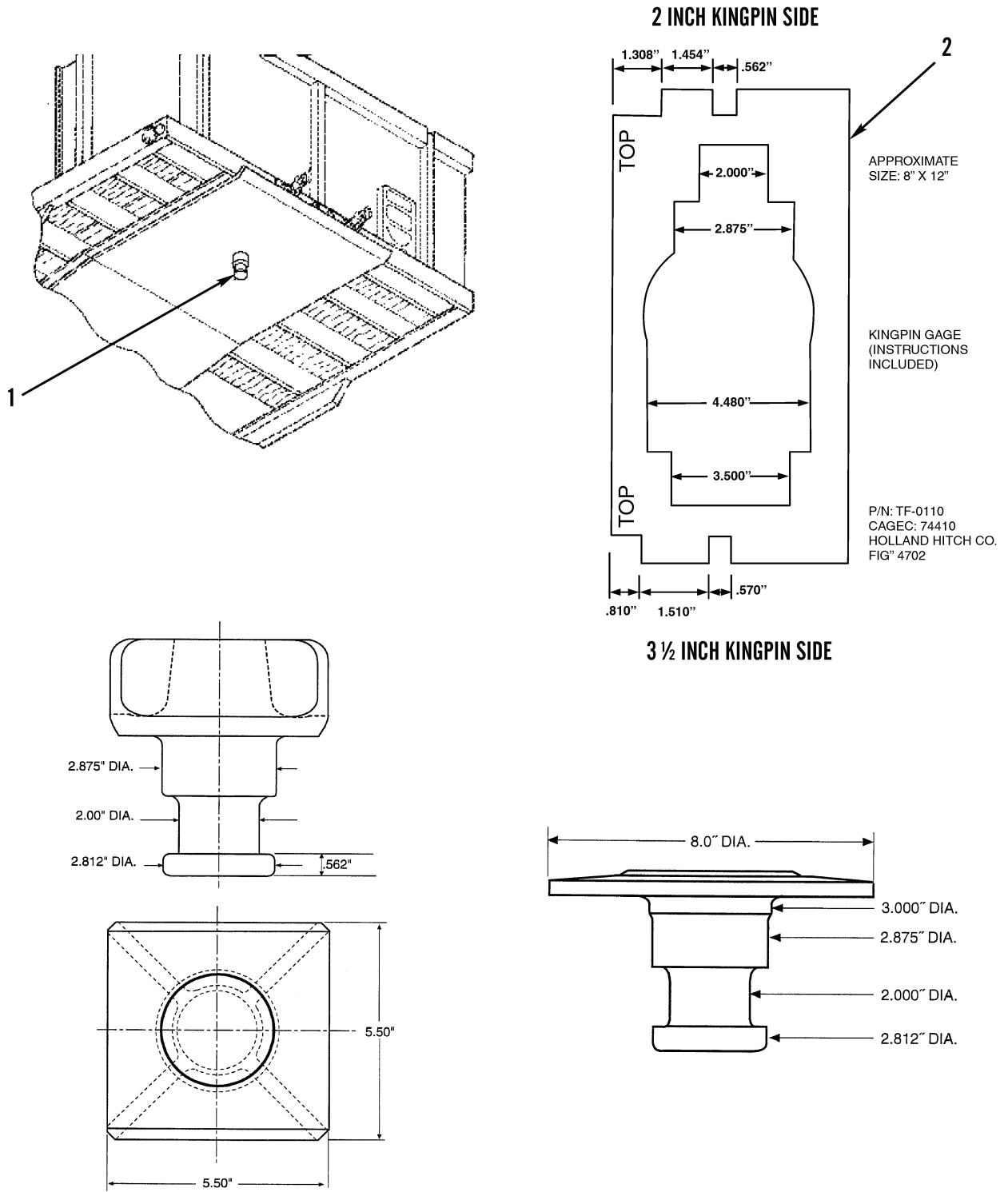

Figure 23. Kingpin.

447-5023

(1) ITEM NO	(2) SMR CODE	(3) NSN	(4) CAGEC	(5) PART NUMBER	(6) DESCRIPTION AND USABLE ON CODES (UOC)	(7) QTY
GROUP 1506 FIFTH WHEEL						
FIG. 23 KINGPIN						
1	PFFZZ	2510015218635	74410	KP-AAR-4	KINGPIN, FIFTH WHEEL 5.5" SQ BASE... UOC:SCB, SJB	1
1	PFFZZ	2510013156287	74410	KP-T-809-F	KINGPIN, FIFTH WHEEL 8.0" DIA ROUND BASE..... UOC:SKB	1
2	PFFZZ	5220015218643	74410	TF-0110	GAGE, PROFILE.....	1

END OF FIGURE

1
2 THRU 21

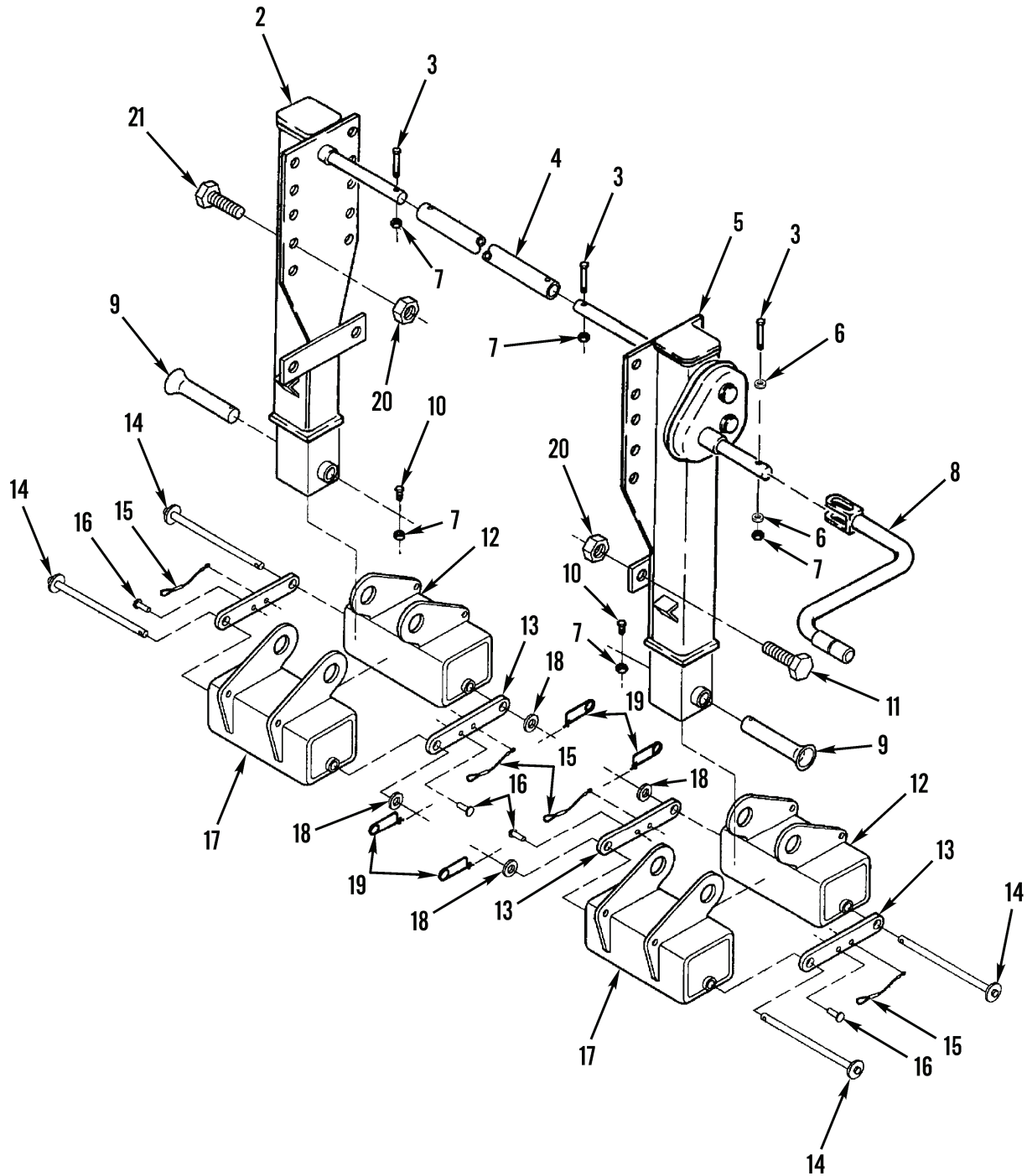
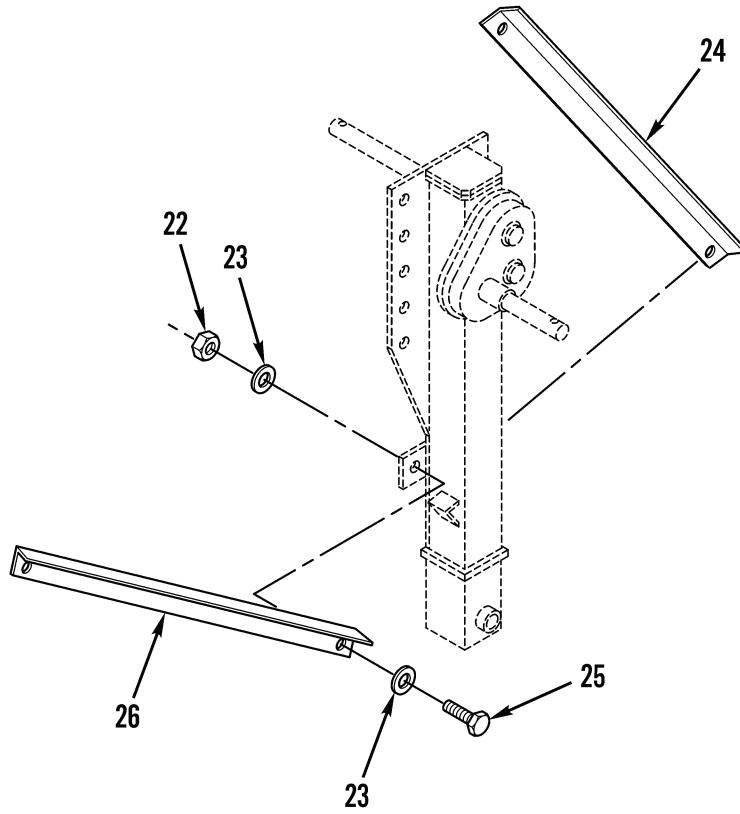

Figure 24. Landing Gear (Sheet 1 of 2).

447-5024-1



MODELS
M871R
M871A1R

Figure 24. Landing Gear (Sheet 2 of 2).

(1) ITEM NO	(2) SMR CODE	(3) NSN	(4) CAGEC	(5) PART NUMBER	(6) DESCRIPTION AND USABLE ON CODES (UOC)	(7) QTY
GROUP 1507 LANDING GEAR, LEVELING JACKS						
FIG. 24 LANDING GEAR						
1	PFOOO	2590015562068	3DGR3	61000034	SUPPORT,RETRACTABLE COMPLETE LANDING LEG ASSEMBLY..... UOC:SJB	1
1	PFOOO	2590015561332	3DGR3	61000048	SUPPORT,RETRACTABLE COMPLETE LANDING LEG ASSEMBLY..... UOC:SCB	1
1	PFOOO		3DGR3	61000010	SUPPORT,RETRACTABLE COMPLETE LANDING LEG ASSEMBLY..... UOC:SKB	1
2	PFOZZ	5305015561408	3DGR3	61000035	.SUPPORT,RETRACTABLE LH..... UOC:SCB,SJB	1
2	PFOZZ	2590014995434	0FBD6	50890077	.SUPPORT,RETRACTABLE LH..... UOC:SKB	1
3	PAOZZ	5305002693217	80205	MS90725-67	.SCREW,CAP,HEXAGON H..... UOC:SKB	3
4	PFOZZ	2590015561718	3DGR3	58080045	.SHAFT,CROSS DRIVE 32 3/8 LONG.....	1
5	PFOZZ	5310015569152	3DGR3	61000036	.SUPPORT,RETRACTABLE RH..... UOC:SCB,SJB	1
5	PFOZZ	2590014995437	0FBD6	50890078	.SUPPORT,RETRACTABLE RH..... UOC:SKB	1
6	PAOZZ	5310011740431	99411	PP0016-03	.WASHER,FLAT..... UOC:SKB	2
7	PAOZZ	5310011269404	7X677	9422297	.NUT,SELF-LOCKING,HE..... UOC:SKB	5
8	PFOZZ	5340011750564	99411	LG0083-05	.CRANK,HAND.....	1
9	PFOZZ	5315013167547	99411	LG0070-02	.PIN,STRAIGHT,HEADLE..... UOC:SKB	2
10	PAOZZ	5305001159526	80204	B1821BH038C075D	.SCREW,CAP,HEXAGON H..... UOC:SKB	2
11	PAOZZ	5305007247222	80204	B1821BH063C200N	.SCREW,CAP,HEXAGON H 5/8-11 X 2.0". UOC:SKB	4
12	PFOZZ	2530014993718	0FBD6	01546002	.BRAKE SHOE FRONT, SCISSOR SHOE....	2
13	PFOZZ	5340014995543	0FBD6	02302044	.PLATE,MOUNTING.....	4
14	PFOZZ	5315014995545	0FBD6	01578006	.PIN,STRAIGHT,HEADED.....	4
15	PFOZZ	4010014997594	0FBD6	50450016	.WIRE ROPE ASSEMBLY,.....	4
16	PFOZZ	5320014995546	0FBD6	52050001	.RIVET,BLIND.....	4
17	PFOZZ	2530014995547	0FBD6	01546003	.BRAKE SHOE REAR, SCISSOR SHOE....	2
18	PAOZZ	5310014993318	0FBD6	02976010	.WASHER,FLAT.....	4
19	PFOZZ	5315014994271	0FBD6	51182002	.PIN,RETAINING.....	4
20	PAOZZ	5310014994273	0FBD6	50995065	.NUT,SELF-LOCKING,HE.....	28
21	PAOZZ	5305014994202	0FBD6	50174006	.SCREW,CAP,HEXAGON H 5/8-11 X 1.50"	28
22	PAOZZ	5310002256993	81349	M45913/1-8CG5C	NUT,SELF-LOCKING,HE..... UOC:SCB,SJB	8
23	PAOZZ	5310008095997	96906	MS27183-17	WASHER,FLAT..... UOC:SCB,SJB	16

(1) ITEM NO	(2) SMR CODE	(3) NSN	(4) CAGEC	(5) PART NUMBER	(6) DESCRIPTION AND USABLE ON CODES (UOC)	(7) QTY
24	PFOZZ	2590015561200	3DGR3	10687100	BRACKET,VEHICULAR C FRONT, SUPPORT. UOC:SJB	2
24	PFOZZ	2590015561276	3DGR3	10687102	BRACKET,VEHICULAR C FRONT, SUPPORT. UOC:SCB	2
25	PAOZZ	5305000712069	80204	B1821BH050C150N	SCREW,CAP,HEXAGON H..... UOC:SCB,SJB	8
26	PFOZZ	2590015561346	3DGR3	10687101	BRACKET,VEHICULAR C REAR, SUPPORT.. UOC:SJB	2
26	PFOZZ	2590015561440	3DGR3	10687103	BRACKET,VEHICULAR C REAR, SUPPORT.. UOC:SCB	2

END OF FIGURE

4
5 THRU 7

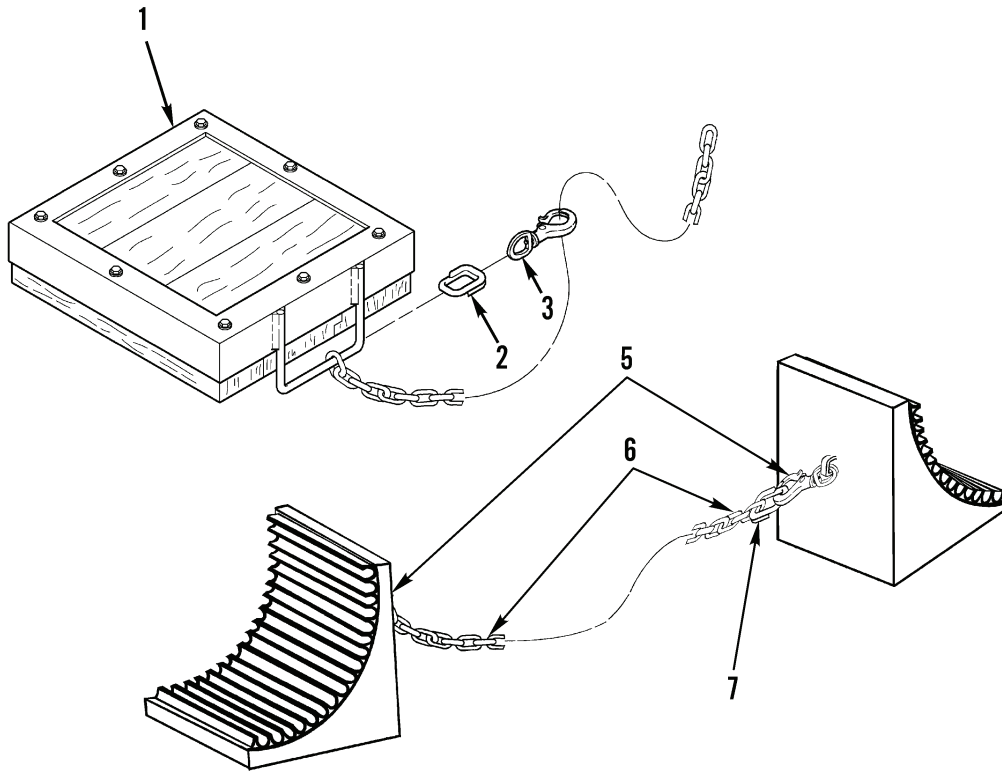

Figure 25. Ground Board Assembly and Chock Blocks.

447-5025

(1) ITEM NO	(2) SMR CODE	(3) NSN	(4) CAGEC	(5) PART NUMBER	(6) DESCRIPTION AND USABLE ON CODES (UOC)	(7) QTY
GROUP 1507 LANDING GEAR, LEVELING JACKS						
FIG. 25 GROUND BOARD ASSEMBLY AND CHOCK BLOCKS						
1	PFOZZ	5340014994251	0FBD6	07758002	BOARD GROUND JACK 18" X 18".....	2
2	PFOZZ	4030014994227	0FBD6	50462035	SHACKLE.....	4
3	PFOZZ	5340014995549	39428	3919T15	CLIP, SPRING TENSION.....	4
4	PFOZZ	2540014995553	0FBD6	07758014	CHOCK, WHEEL-TRACK.....	2
5	PFOZZ	5340014995549	39428	3919T15	.CLIP, SPRING TENSION.....	2
6	PFOZZ	4010014995145	0FBD6	04626004	.CHAIN, WELDED.....	1
7	PFOZZ	4030014994227	0FBD6	50462035	.SHACKLE.....	2

END OF FIGURE

1
2 THRU 25

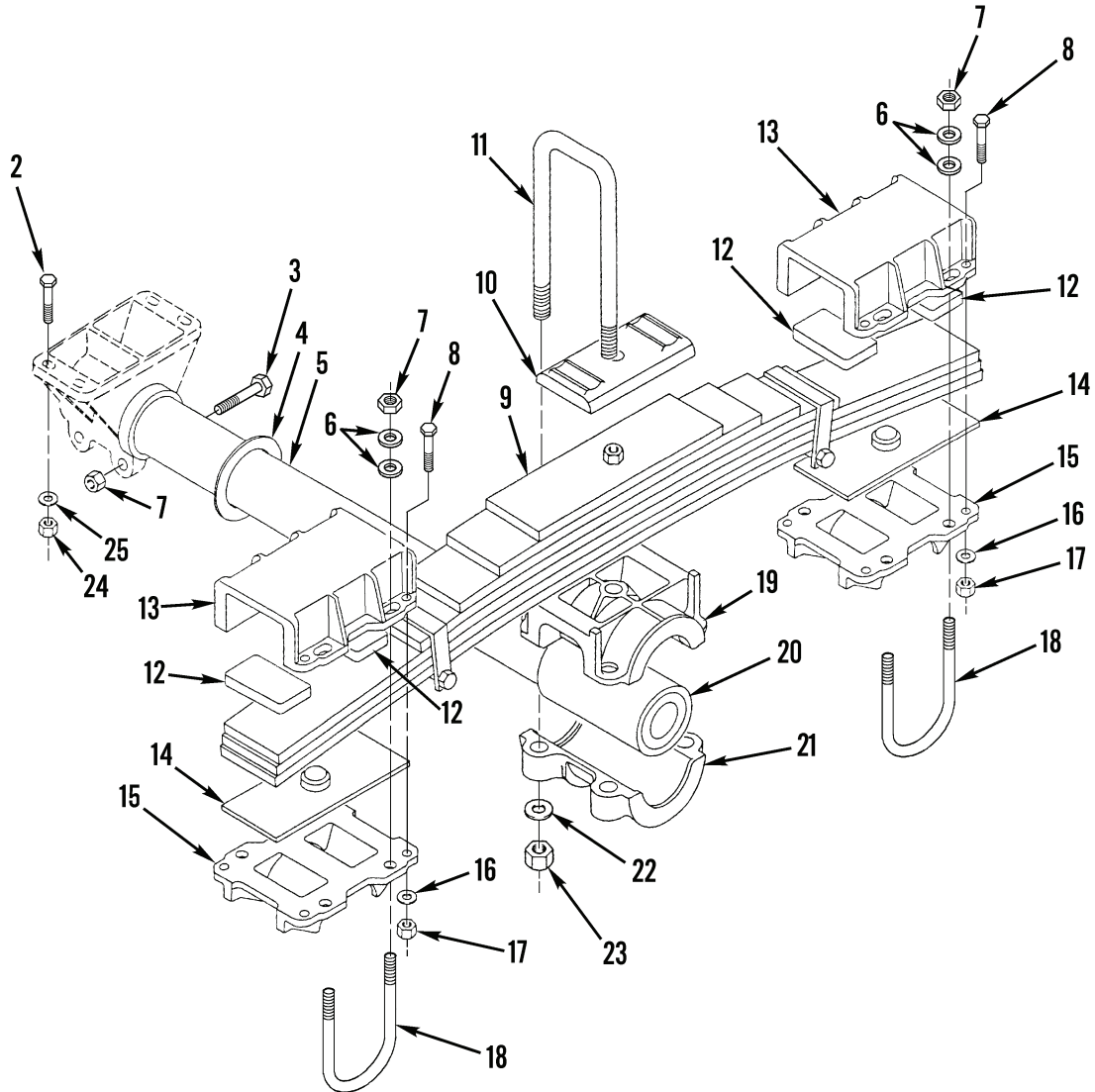

OVERSLUNG TRUNNION/OVERSLUNG AXLE

MODELS
M871R
M871A1R

Figure 26. Suspension (Sheet 1 of 2).

26
27 THRU 50

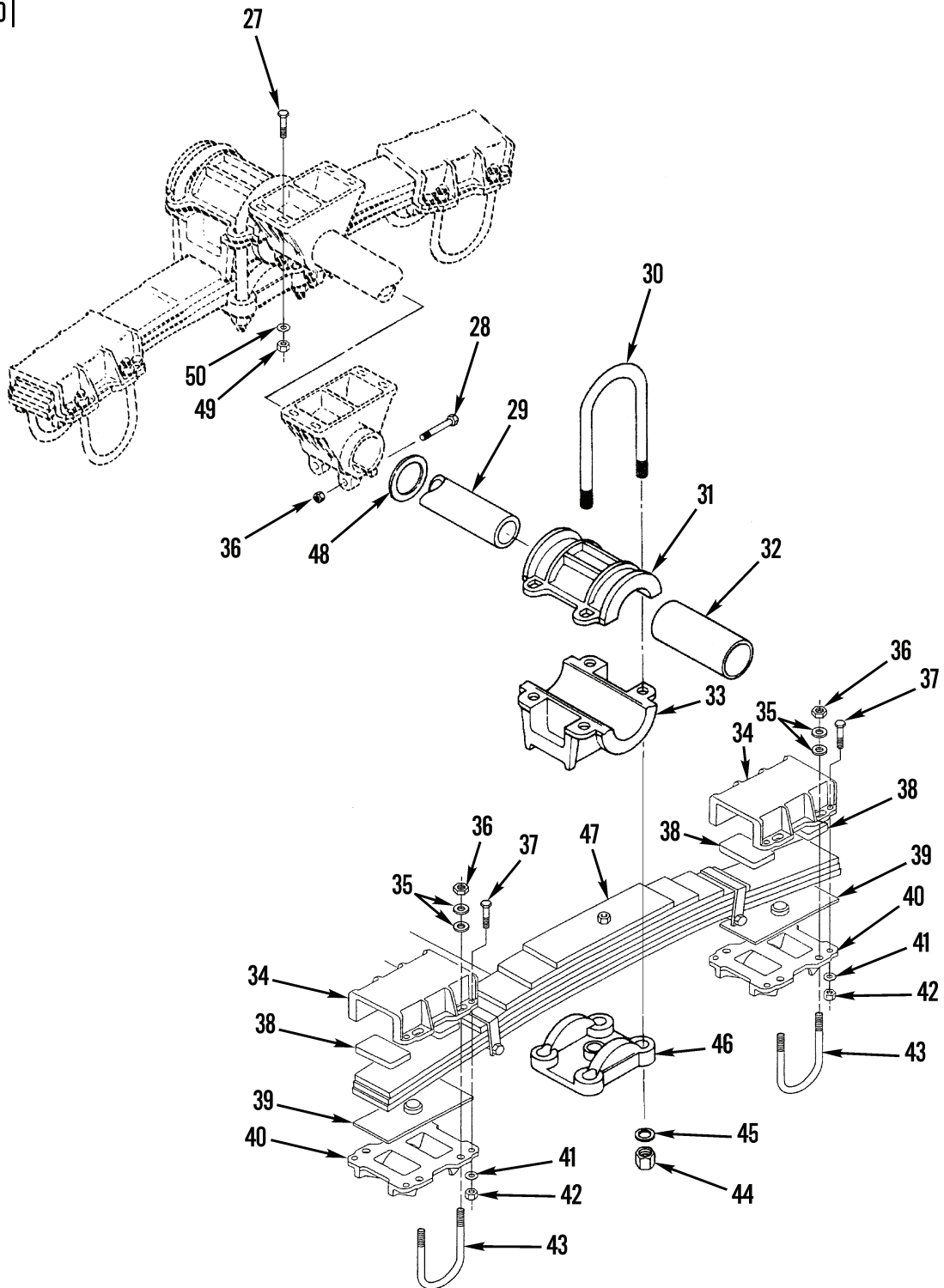

**UNDERSLUNG TRUNNION/OVERSLUNG AXLE
MODEL M871A2R**

Figure 26. Suspension (Sheet 2 of 2).

447-5026-2

(1) ITEM NO	(2) SMR CODE	(3) NSN	(4) CAGEC	(5) PART NUMBER	(6) DESCRIPTION AND USABLE ON CODES (UOC)	(7) QTY
GROUP 16 SPRINGS AND SHOCK ABSORBERS						
GROUP 1601 SPRINGS						
FIG. 26 SUSPENSION						
1	XDFFF		3DGR3	61000008	SUSPENSION ASSEMBLY COMPLETE LESS AXLE..... UOC:SCB, SJB	1
2	PAFZZ	5305014994217	0FBD6	50174017	.SCREW, CAP, HEXAGON H..... UOC:SCB, SJB	8
3	PAFZZ	5305009408069	92967	10376-00	.SCREW, CAP, HEXAGON H..... UOC:SCB, SJB	4
4	PAFZZ	5310010987247	92967	895-00	.WASHER, FLAT..... UOC:SCB, SJB	2
5	PPFZZ	4710012409431	92967	B893-02	.TUBE, METALLIC..... UOC:SCB, SJB	1
6	PAFZZ	5310010987245	92967	817-00	.WASHER, FLAT..... UOC:SCB, SJB	32
7	PAFZZ	5310010987827	92967	841-00	.NUT, SELF-LOCKING, HE..... UOC:SCB, SJB	20
8	PAFZZ	5305007262551	80204	B1821BH063F200N	.SCREW, CAP, HEXAGON H..... UOC:SCB, SJB	8
9	PPFZZ	5360014994204	92967	10055-00	.SPRING, HELICAL, COMP 7 LEAF..... UOC:SCB, SJB	1
10	PPFZZ	2510011012559	92967	9640-00	.PLATE, WEAR, LEAF SPR..... UOC:SCB, SJB	2
11	PPFZZ	5306010987198	92967	9639-03	BOLT, U..... UOC:SCB, SJB	4
12	PPFZZ	2590011009001	92967	814-00	.PAD, CUSHIONING..... UOC:SCB, SJB	4
13	PPFZZ	2510011007167	92967	9937-00	.END CAP, SPRING..... UOC:SCB, SJB	2
14	PPFZZ	2510011012890	92967	10608-00	.PLATE, ALIGNMENT, LEA..... UOC:SCB, SJB	2
15	PPFZZ	2510011009270	92967	9934-02	.SEAT, LEAF SPRING..... UOC:SCB, SJB	2
16	PAFZZ	5310010987244	92967	10273-00	.WASHER, FLAT..... UOC:SCB, SJB	8
17	PAFZZ	5310014994209	92967	11513-03	.NUT, SELF-LOCKING, HE..... UOC:SCB, SJB	8
18	PPFZZ	5306010987197	92967	10060-01	.BOLT, U..... UOC:SCB, SJB	8
19	PPFZZ	2520011010935	92967	891-00	.HUB TRUNNION, UPPER..... UOC:SCB, SJB	2
20	PPFZZ	5365013163300	92967	23276.01	.BUSHING, NONMETALLIC..... UOC:SCB, SJB	2
21	PPFZZ	2520011012551	92967	898-00	.TRUNNION, HUB, LOWER..... UOC:SCB, SJB	2

(1) ITEM NO	(2) SMR CODE	(3) NSN	(4) CAGEC	(5) PART NUMBER	(6) DESCRIPTION AND USABLE ON CODES (UOC)	(7) QTY
22	PAFZZ	5310010987246	92967	837-00	.WASHER, FLAT..... UOC:SCB, SJB	8
23	PAFZZ	5310010987236	92967	836-00	.NUT, PLAIN, HEXAGON..... UOC:SCB, SJB	8
24	PAFZZ	5310014994273	0FBD6	50995065	.NUT, SELF-LOCKING, HE..... UOC:SCB, SJB	8
25	PAFZZ	5310014994211	0FBD6	55752009	.WASHER, FLAT..... UOC:SCB, SJB	8
26	XDFFF		3DGR3	61000008	SUSPENSION ASSEMBLY COMPLETE LESS AXLE..... UOC:SKB	1
27	PAFZZ	5305014994217	0FBD6	50174017	.SCREW, CAP, HEXAGON H..... UOC:SKB	8
28	PAFZZ	5305009408069	92967	10376-00	.SCREW, CAP, HEXAGON H..... UOC:SKB	4
29	PFFZZ	4710012409431	92967	B893-02	.TUBE, METALLIC..... UOC:SKB	1
30	PFFZZ	5306013212386	92967	835-04	.BOLT, U..... UOC:SKB	4
31	PFFZZ	2520011010935	92967	891-00	.HUB TRUNNION, UPPER..... UOC:SKB	2
32	PFFZZ	5365013163300	92967	23276.01	.BUSHING, NONMETALLIC..... UOC:SKB	2
33	PFFZZ	2520011012551	92967	898-00	.TRUNNION, HUB, LOWER..... UOC:SKB	2
34	PFFZZ	2510011007167	92967	9937-00	.END CAP, SPRING..... UOC:SKB	2
35	PAFZZ	5310010987245	92967	817-00	.WASHER, FLAT..... UOC:SKB	32
36	PAFZZ	5310010987827	92967	841-00	.NUT, SELF-LOCKING, HE..... UOC:SKB	20
37	PAFZZ	5305007262551	80204	B1821BH063F200N	.SCREW, CAP, HEXAGON H..... UOC:SKB	8
38	PFFZZ	2590011009001	92967	814-00	.PAD, CUSHIONING..... UOC:SKB	4
39	PFFZZ	2510011012890	92967	10608-00	.PLATE, ALIGNMENT, LEA..... UOC:SKB	2
40	PFFZZ	2510011009270	92967	9934-02	.SEAT, LEAF SPRING..... UOC:SKB	2
41	PAFZZ	5310010987244	92967	10273-00	.WASHER, FLAT..... UOC:SKB	8
42	PAFZZ	5310014994209	92967	11513-03	.NUT, SELF-LOCKING, HE..... UOC:SKB	8
43	PFFZZ	5306010987197	92967	10060-01	.BOLT, U..... UOC:SKB	8
44	PAFZZ	5310010987236	92967	836-00	.NUT, PLAIN, HEXAGON..... UOC:SKB	8
45	PAFZZ	5310010987246	92967	837-00	.WASHER, FLAT..... UOC:SKB	8

(1) ITEM NO	(2) SMR CODE	(3) NSN	(4) CAGEC	(5) PART NUMBER	(6) DESCRIPTION AND USABLE ON CODES (UOC)	(7) QTY
46	PPFZZ	2510011012559	92967	9640-00	.PLATE, WEAR, LEAF SPR..... UOC:SKB	2
47	PPFZZ	5360014994204	92967	10055-00	.SPRING, HELICAL, COMP 7 LEAF..... UOC:SKB	1
48	PAFZZ	5310010987247	92967	895-00	.WASHER, FLAT..... UOC:SKB	2
49	PAFZZ	5310014994273	0FBD6	50995065	.NUT, SELF-LOCKING, HE..... UOC:SKB	8
50	PAFZZ	5310014994211	0FBD6	55752009	.WASHER, FLAT..... UOC:SKB	8

END OF FIGURE

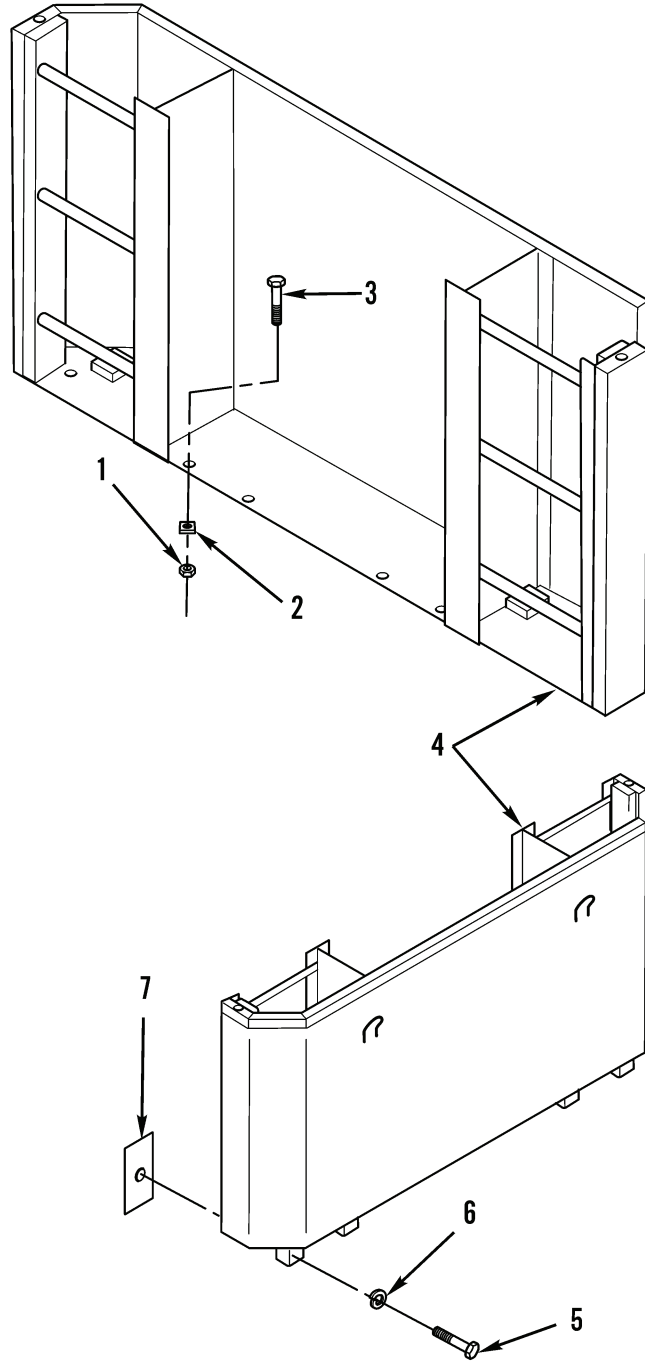

Figure 27. Bulkhead and Stowage Rack Assembly.

447-5027

(1) ITEM NO	(2) SMR CODE	(3) NSN	(4) CAGEC	(5) PART NUMBER	(6) DESCRIPTION AND USABLE ON CODES (UOC)	(7) QTY
-------------------	--------------------	------------	--------------	-----------------------	--	------------

GROUP 18 BODY, CAB, HOOD, AND HULL

GROUP 1801 BODY, CAB, HOOD, AND HULL
ASSEMBLIES

FIG. 27 BULKHEAD AND STOWAGE RACK
ASSEMBLY

1	PAOZZ	5310000614651	81349	M45913/1-10CG8C	NUT, SELF-LOCKING, HE 5/8-11".....	4
2	PAOZZ	5310015562138	3DGR3	02321502	WASHER, FLAT 1.5 X 2.0 X 0.25" THK..	4
3	PAOZZ	5305007247222	80204	B1821BH063C200N	SCREW, CAP, HEXAGON H 5/8-11 X 2.00".	4
4	PFOZZ	2510015561279	3DGR3	61000004	BULKHEAD ASSEMBLY.....	1
5	PAOZZ	5305000712069	80204	B1821BH050C150N	SCREW, CAP, HEXAGON H 1/2-13 X 1.50".	4
6	PAOZZ	5310005845272	80205	MS35338-48	WASHER, LOCK 1/2".....	4
7	PFOZZ		3DGR3	05472019	PLATE, MOUNTING 1.5 X 5.0 X 0.25" THK WITHWELDED NUT.....	4

END OF FIGURE

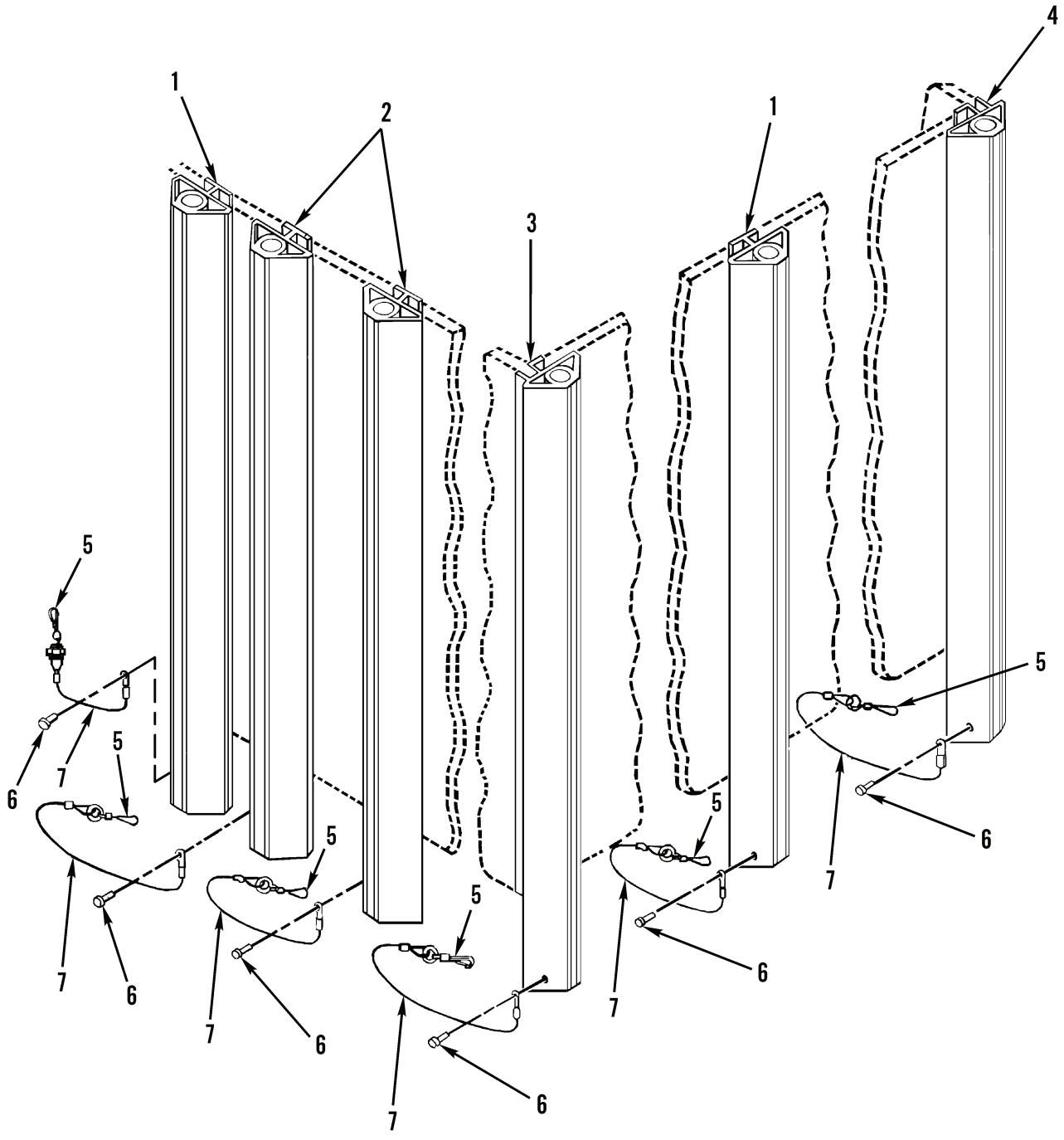
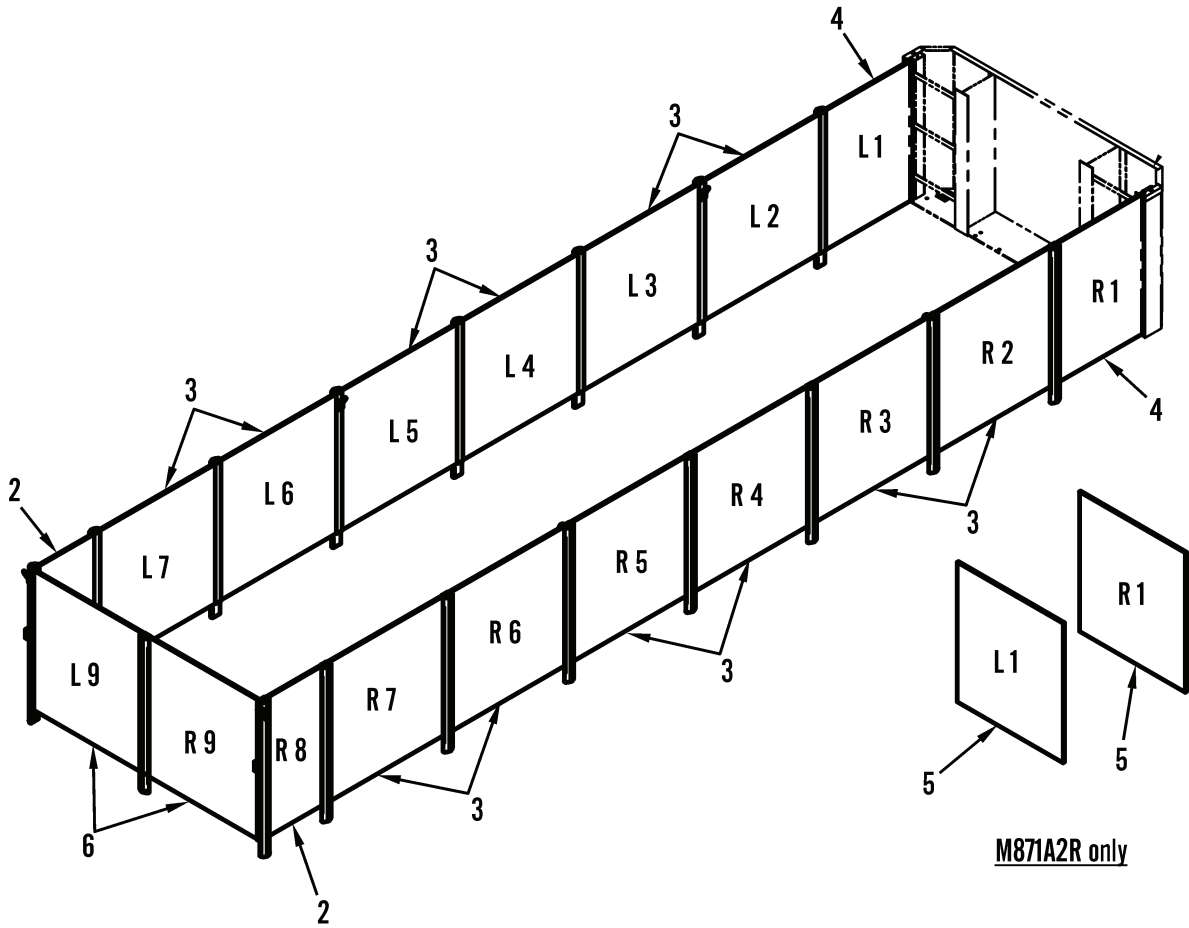

Figure 28. Front, Side, and Rear Stakes.

(1) ITEM NO	(2) SMR CODE	(3) NSN	(4) CAGEC	(5) PART NUMBER	(6) DESCRIPTION AND USABLE ON CODES (UOC)	(7) QTY
GROUP 1801 BODY, CAB, HOOD, AND HULL ASSEMBLIES						
FIG. 28 FRONT, SIDE, AND REAR STAKES						
1	PFOZZ	2510014997638	0FBD6	04696003	STAKE,VEHICLE BODY REAR CENTER AND SIDES.....	11
2	PFOZZ	2510014993799	0FBD6	04696001	STAKE,VEHICLE BODY CROSS CHAIN STAKES.....	4
3	PFOZZ	2510014997636	0FBD6	04696002	STAKE,VEHICLE BODY LEFT REAR CORNER	1
4	PFOZZ	2510015561390	3DGR3	04696005	STAKE,VEHICLE BODY RIGHT REAR CORNER.....	1
5	PFOZZ	5340014994157	0FBD6	50462030	SNAP HOOK.....	17
6	PFOZZ	5320014995546	0FBD6	52050001	RIVET,BLIND.....	17
7	PFOZZ	4010014997594	0FBD6	50450016	WIRE ROPE ASSEMBLY,.....	17

END OF FIGURE

1
2 THRU 6
PLUS STAKES
ON FIG. 28



See Fig. 28 for Stakes

Figure 29. Side and Rear Boards.

(1) ITEM NO	(2) SMR CODE	(3) NSN	(4) CAGEC	(5) PART NUMBER	(6) DESCRIPTION AND USABLE ON CODES (UOC)	(7) QTY
GROUP 1801 BODY, CAB, HOOD, AND HULL ASSEMBLIES						
FIG. 29 SIDE AND REAR BOARDS						
1	PFOZZ	2510015561448	3DGR3	61000051	STAKE,VEHICLE BODY INCLUDES ALL SIDEBOARDS AND STAKES.....	1
2	PFOZZ	2510015561938	3DGR3	04694014	.SIDE RACK,VEHICULAR 23.75 X 48", SIDE REAR.....	2
3	PFOZZ	5530014993391	0FBD6	04694006	.PLYWOOD,CONSTRUCTIO 47 3/4 X 48", SIDES.....	12
4	PFOZZ	5530014993386	0FBD6	04694005	.PLYWOOD,CONSTRUCTIO 35.75 X 48", SIDE FRONT..... UOC:SCB,SJB	2
5	PFOZZ	2510015561934	3DGR3	04694015	.SIDE RACK,VEHICULAR 42 X 48", SIDE FRONT..... UOC:SJB,SKB	2
6	PFOZZ	5530015561274	0FBD6	04694012	.PLYWOOD,CONSTRUCTIO 44 X 48", REAR	2

END OF FIGURE

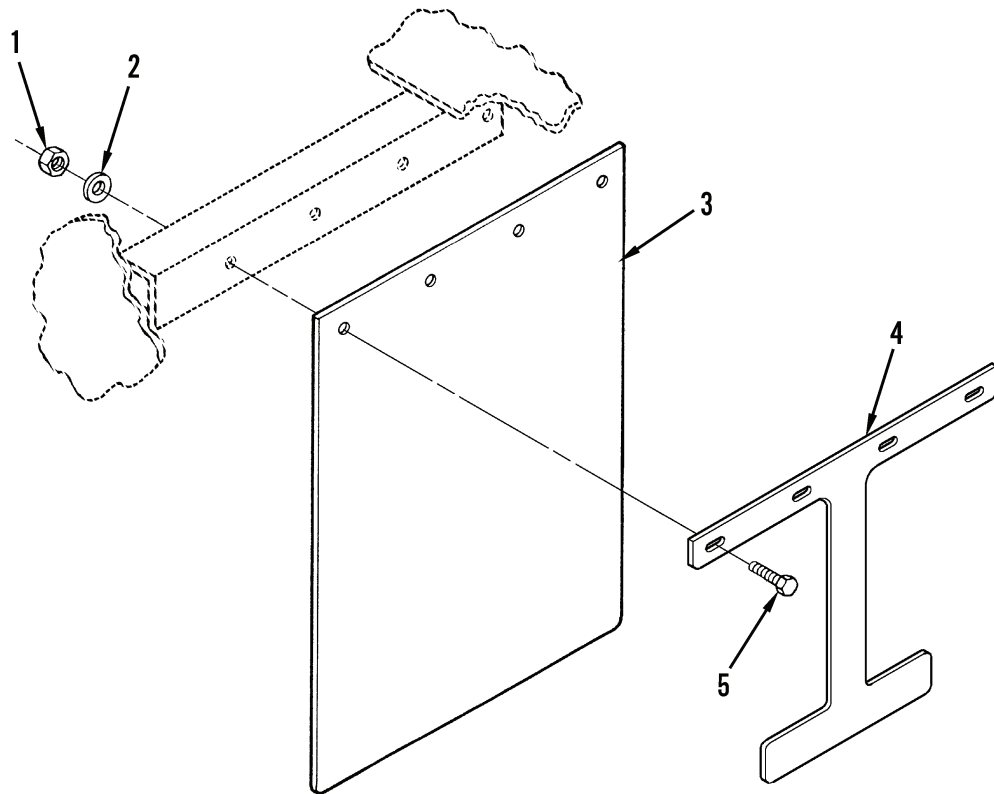

ANTI SAIL

Figure 30. Mud Flaps.

(1) ITEM NO	(2) SMR CODE	(3) NSN	(4) CAGEC	(5) PART NUMBER	(6) DESCRIPTION AND USABLE ON CODES (UOC)	(7) QTY
-------------------	--------------------	------------	--------------	-----------------------	--	------------

GROUP 1801 BODY, CAB, HOOD, AND HULL
ASSEMBLIES

FIG. 30 MUD FLAPS

1	PAOZZ	5310014993456	0FBD6	50995054	NUT, SELF-LOCKING, HE.....	8
2	PAOZZ	5310014993461	0FBD6	55752005	WASHER, FLAT.....	8
3	PFOZZ	2540014994246	0FBD6	50822014	GUARD, SPLASH, VEHICU 24" X 36".....	2
4	PFOZZ	5340014993409	0FBD6	07430072	BRACKET, MOUNTING.....	2
5	PAOZZ	5305014993465	0FBD6	50172008	SCREW, CAP, HEXAGON H.....	8

END OF FIGURE

1
2 THRU 14

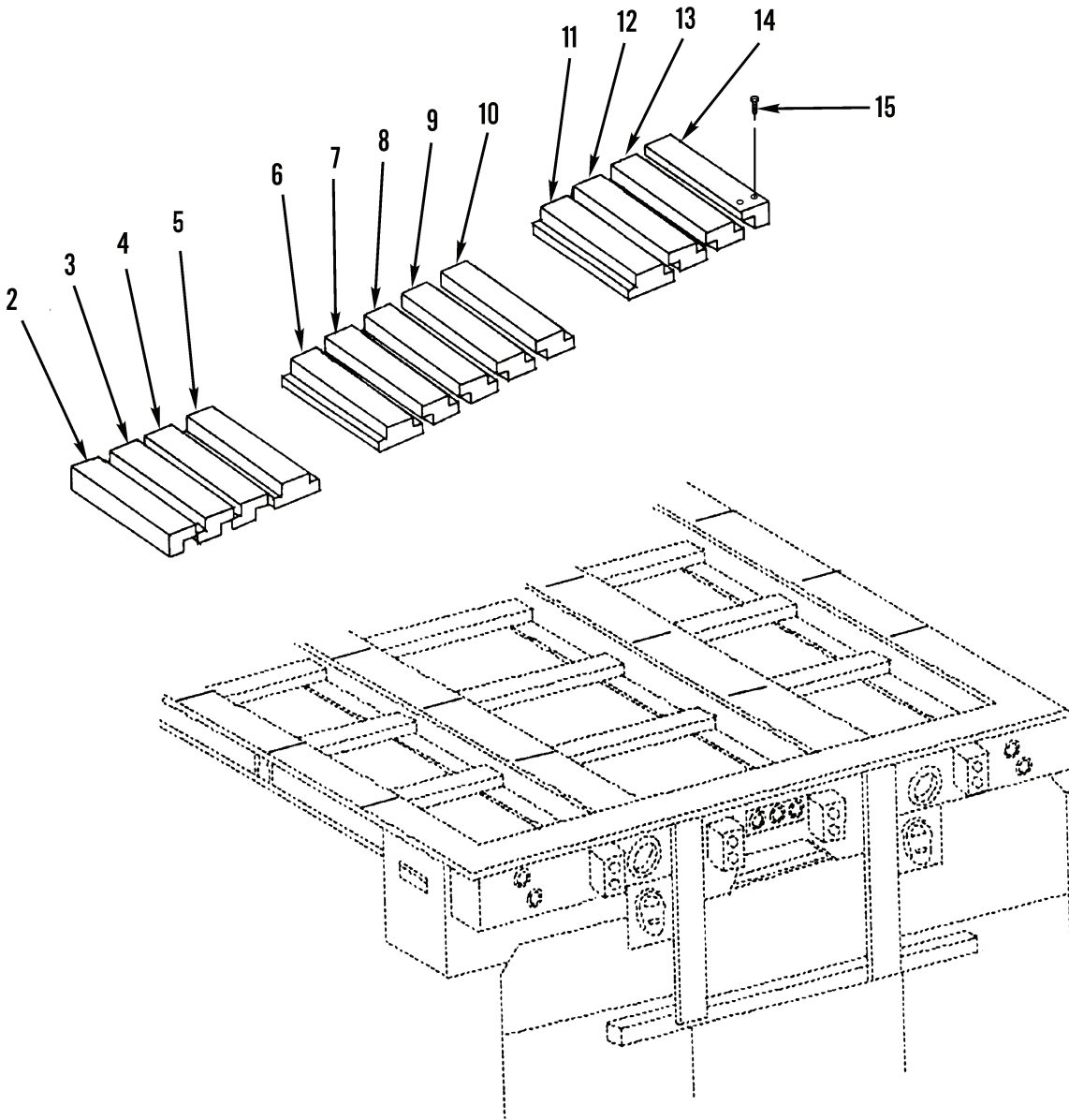

M871R AND M871A1R

Figure 31. Floor Decking (Sheet 1 of 2).

16
17 THRU 27

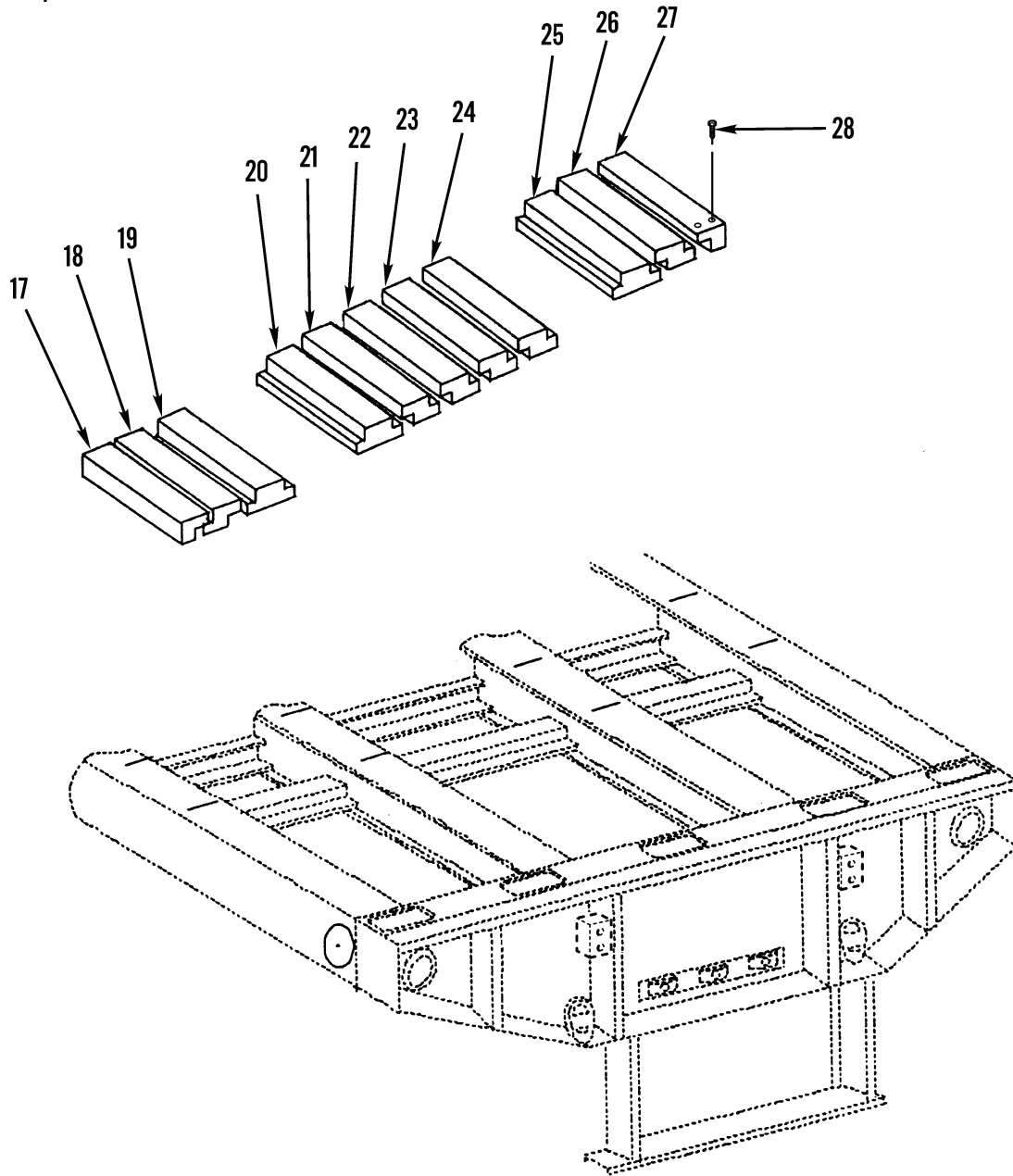

M871A2R

Figure 31. Floor Decking (Sheet 2 of 2).

(1) ITEM NO	(2) SMR CODE	(3) NSN	(4) CAGEC	(5) PART NUMBER	(6) DESCRIPTION AND USABLE ON CODES (UOC)	(7) QTY
GROUP 1805 FLOORS, SUBFLOORS, AND RELATED COMPONENTS						
FIG. 31 FLOOR DECKING						
1	PFOZZ	2510015588153	8N013	M871-A1-KIT	FLOORING, KIT INCLUDES 13 BOARDS EA 19 FT..... UOC:SCB, SJB	1
2	PFOZZ	5510015561819	8N013	M871-A1-A	.LUMBER, HARDWOOD CUT TO FIT..... UOC:SCB, SJB	1
3	PFOZZ	5510015588143	8N013	M871-A1-B	.BOARD, DECKING CUT TO FIT..... UOC:SCB, SJB	1
4	PFOZZ	5510015588767	8N013	M871-A1-C	.BOARD, DECKING CUT TO FIT..... UOC:SCB, SJB	1
5	PFOZZ	5510015590836	8N013	M871-A1-D	.BOARD, DECKING CUT TO FIT..... UOC:SCB, SJB	1
6	PFOZZ	5510015589542	8N013	M871-A1-E	.BOARD, DECKING CUT TO FIT..... UOC:SCB, SJB	1
7	PFOZZ	5510015588397	8N013	M871-A1-F	.BOARD, DECKING CUT TO FIT..... UOC:SCB, SJB	1
8	PFOZZ	5510015588545	8N013	M871-A1-G	.BOARD, DECKING CUT TO FIT..... UOC:SCB, SJB	1
9	PFOZZ	5510015590830	8N013	M871-A1-H	.BOARD, DECKING CUT TO FIT..... UOC:SCB, SJB	1
10	PFOZZ	5510015589549	8N013	M871-A1-J	.BOARD, DECKING CUT TO FIT..... UOC:SCB, SJB	1
11	PFOZZ	5510015588144	8N013	M871-A1-K	.BOARD, DECKING CUT TO FIT..... UOC:SCB, SJB	1
12	PFOZZ	5510015588572	8N013	M871-A1-L	.BOARD, DECKING CUT TO FIT..... UOC:SCB, SJB	1
13	PFOZZ	5510015588489	8N013	M871-A1-M	.BOARD, DECKING CUT TO FIT..... UOC:SCB, SJB	1
14	PFOZZ	5510015590847	8N013	M871-A1-N	.BOARD, DECKING CUT TO FIT..... UOC:SCB, SJB	1
15	PAOZZ	5305014997657	0FBD6	52116040	SCREW, MACHINE..... UOC:SKB	326
16	PFOZZ	2510015212739	8N013	M871A2-KIT	PARTS KIT, FLOOR, VEH INCLUDES 11 BOARDS (6) 30FT & (5) 19FT..... UOC:SKB	1
17	PFOZZ	2510015214248	8N013	M871A2-A	.FLOOR, BODY, VEHICULA CUT TO FIT.... UOC:SKB	1
18	PFOZZ	2510015214252	8N013	M871A2-B	.FLOOR, BODY, VEHICULA CUT TO FIT.... UOC:SKB	1
19	PFOZZ	2510015214255	8N013	M871A2-C	.FLOOR, BODY, VEHICULA CUT TO FIT.... UOC:SKB	1
20	PFOZZ	2510015214213	8N013	M871A2-D	.FLOOR, BODY, VEHICULA CUT TO FIT.... UOC:SKB	1
21	PFOZZ	2510015214217	8N013	M871A2-E	.FLOOR, BODY, VEHICULA CUT TO FIT.... UOC:SKB	1

(1) ITEM NO	(2) SMR CODE	(3) NSN	(4) CAGEC	(5) PART NUMBER	(6) DESCRIPTION AND USABLE ON CODES (UOC)	(7) QTY
22	PFOZZ	2510015214228	8N013	M871A2-F	. FLOOR, BODY, VEHICULA CUT TO FIT.... UOC:SKB	1
23	PFOZZ	2510015214230	8N013	M871A2-G	. FLOOR, BODY, VEHICULA CUT TO FIT.... UOC:SKB	1
24	PFOZZ	2510015214399	8N013	M871A2-H	. FLOOR, BODY, VEHICULA CUT TO FIT.... UOC:SKB	1
25	PFOZZ	2510015214232	8N013	M871A2-J	. FLOOR, BODY, VEHICULA CUT TO FIT.... UOC:SKB	1
26	PFOZZ	2510015214245	8N013	M871A2-K	. FLOOR, BODY, VEHICULA CUT TO FIT.... UOC:SKB	1
27	PFOZZ	2510015214208	8N013	M871A2-L	. FLOOR, BODY, VEHICULA CUT TO FIT.... UOC:SKB	1
28	PAOZZ	5305014997657	0FBD6	52116040	SCREW, MACHINE..... UOC:SKB	326

END OF FIGURE

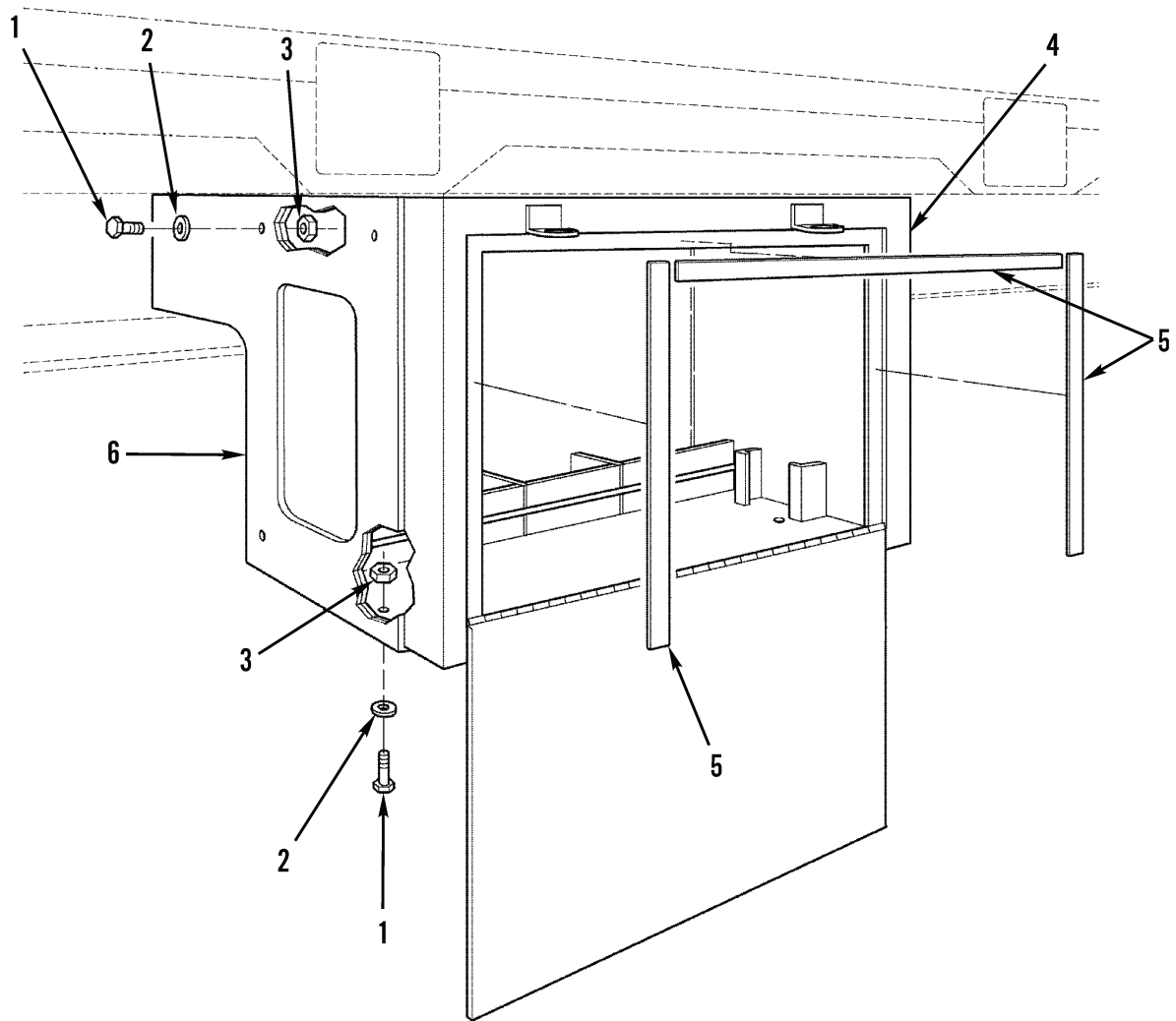

Figure 32. Stowage Box.

(1) ITEM NO	(2) SMR CODE	(3) NSN	(4) CAGEC	(5) PART NUMBER	(6) DESCRIPTION AND USABLE ON CODES (UOC)	(7) QTY
-------------------	--------------------	------------	--------------	-----------------------	--	------------

GROUP 1808 STOWAGE RACK, BOXES,
STRAPS, CARRYING CASES, CABLE REELS,
HOSE REELS, ECT.

FIG. 32 STOWAGE BOX

1	PAOZZ	5305014997665	0FBD6	50173008	SCREW, CAP, HEXAGON H.....	8
2	PAOZZ	5310014993687	0FBD6	55752007	WASHER, FLAT.....	16
3	PAOZZ	5310014993682	0FBD6	50995056	NUT, SELF-LOCKING, HE.....	8
4	PFOFF	2540014993425	0FBD6	00166005	BOX, ACCESSORIES STO.....	1
5	PFOZZ	5330015561405	3DGR3	52600090	SEAL, NONMETALLIC ST CUT TO FIT, (9 FT).....	1
6	PFFZZ	2590015561273	3DGR3	00028263	BRACKET, VEHICULAR C LH, WELDMENT... UOC:SKB	1
6	PFFZZ	2590015561385	3DGR3	00028264	BRACKET, VEHICULAR C RH, WELDMENT... UOC:SKB	1

END OF FIGURE

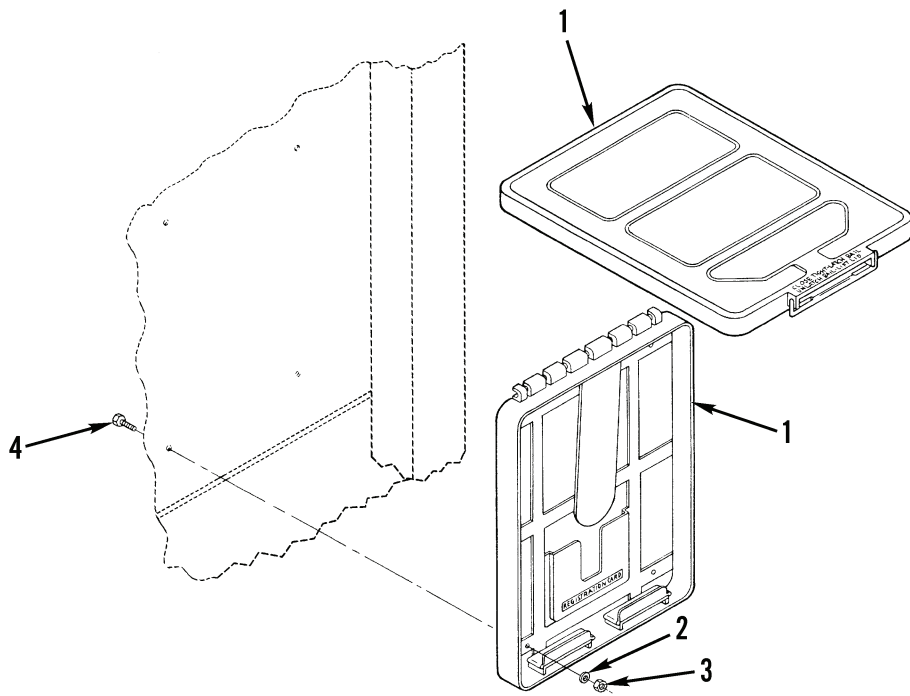
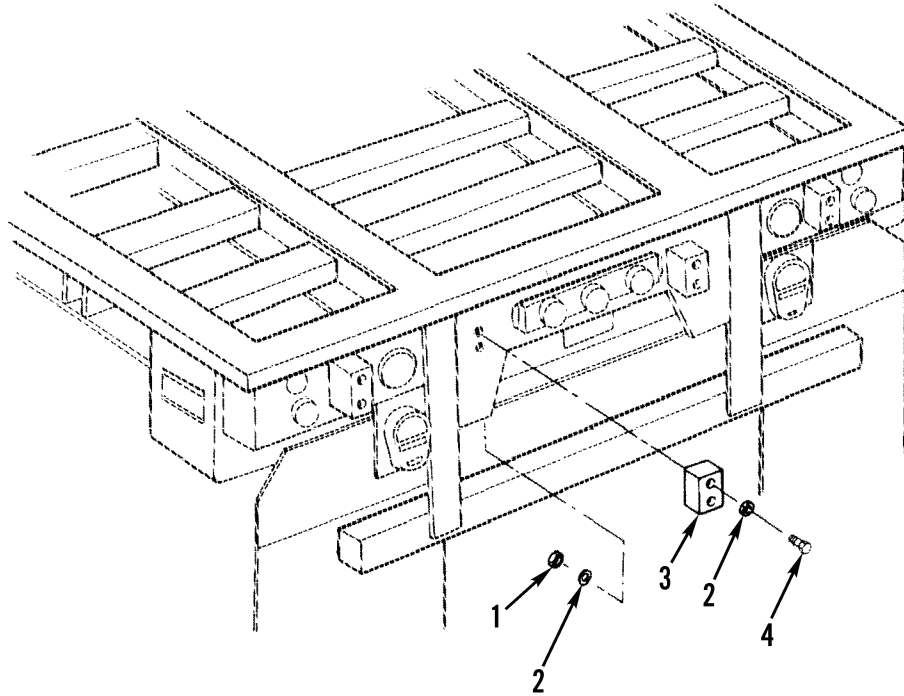

Figure 33. Manifest Box.

(1) ITEM NO	(2) SMR CODE	(3) NSN	(4) CAGEC	(5) PART NUMBER	(6) DESCRIPTION AND USABLE ON CODES (UOC)	(7) QTY
					GROUP 1808 STOWAGE RACK, BOXES, STRAPS, CARRYING CASES, CABLE REELS, HOSE REELS, ECT.	
					FIG. 33 MANIFEST BOX	
1	PAOZZ	7520013243687	1JA34	550	BOX, FILING.....	1
2	PAOZZ	5310015046159	0FBD6	55752003	WASHER, FLAT 0.25 Z/PLATED.....	4
3	PAOZZ	5310014994253	0FBD6	50995050	NUT, SELF-LOCKING, HE 0.25-20 NLN/ INSERT.....	4
4	PAOZZ	5305014994256	0FBD6	50170005	SCREW, CAP, HEXAGON H 0.25-20 X 1"...	4

END OF FIGURE

MODEL
M871R
M871A1R



MODEL
M871A2R

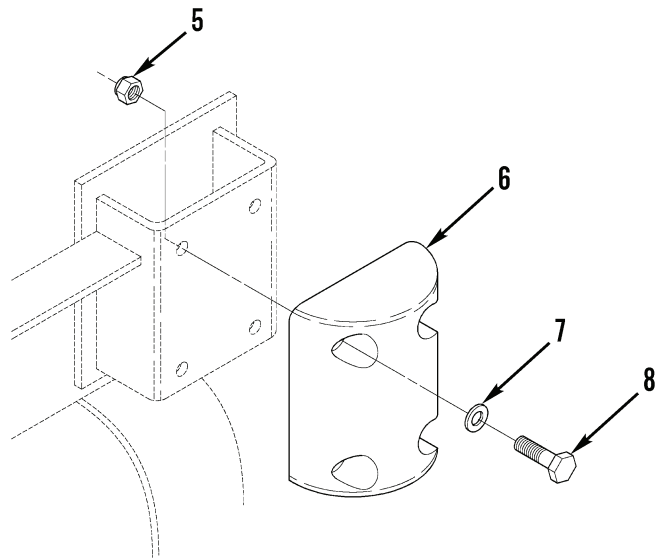

Figure 34. Rubber Dock Bumpers.

(1) ITEM NO	(2) SMR CODE	(3) NSN	(4) CAGEC	(5) PART NUMBER	(6) DESCRIPTION AND USABLE ON CODES (UOC)	(7) QTY
GROUP 21 BUMPERS, GUARDS, AND MARINE FENDERS						
GROUP 2101 BUMPERS, BRACKETS, GUARDS, AND PROTECTIVE DEVICES						
FIG. 34 RUBBER DOCK BUMPERS						
1	PAOZZ	5310007638920	96906	MS51967-20	NUT, PLAIN, HEXAGON..... UOC:SJB	8
1	PAOZZ	5310002694040	81349	M45913/1-10CG5C	NUT, SELF-LOCKING, HE..... UOC:SCB	8
2	PAOZZ	5310008238803	96906	MS27183-21	WASHER, FLAT..... UOC:SCB, SJB	16
3	PAOZZ	5340011126396	83473	TB-20	BUMPER..... UOC:SJB	4
3	PAOZZ	5340012641579	66788	SL1000	BUMPER..... UOC:SCB	4
4	PAOZZ	5305007246761	80205	MS90725-167	SCREW, CAP, HEXAGON H..... UOC:SCB, SJB	8
5	PAOZZ	5310004883889	96906	MS51943-39	NUT, SELF-LOCKING, HE..... UOC:SKB	8
6	PFOZZ	5340013179251	6T589	RC71-68	BUMPER..... UOC:SKB	2
7	PAOZZ	5310008095997	96906	MS27183-17	WASHER, FLAT..... UOC:SKB	8
8	PAOZZ	5305000712073	80204	B1821BH050C250N	SCREW, CAP, HEXAGON H..... UOC:SKB	8

END OF FIGURE

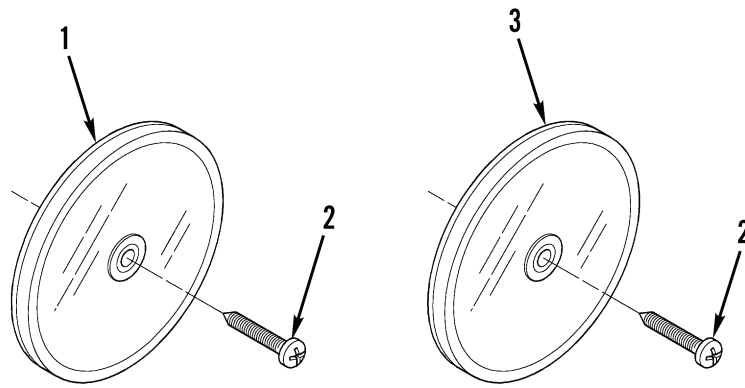

Figure 35. Reflectors.

(1) ITEM NO	(2) SMR CODE	(3) NSN	(4) CAGEC	(5) PART NUMBER	(6) DESCRIPTION AND USABLE ON CODES (UOC)	(7) QTY
-------------------	--------------------	------------	--------------	-----------------------	--	------------

GROUP 22 BODY, CHASSIS AND HULL
ACCESSORY ITEMS

GROUP 2202 ACCESSORY ITEMS

FIG. 35 REFLECTORS

1	PAOZZ	9905013527999	13548	98006Y	REFLECTOR, INDICATING YELLOW.....	4
2	PAOZZ	5305014995551	0FBD6	52100010	SCREW, TAPPING.....	8
3	PAOZZ	9905013431011	13548	98006R	REFLECTOR, INDICATING RED.....	4

END OF FIGURE

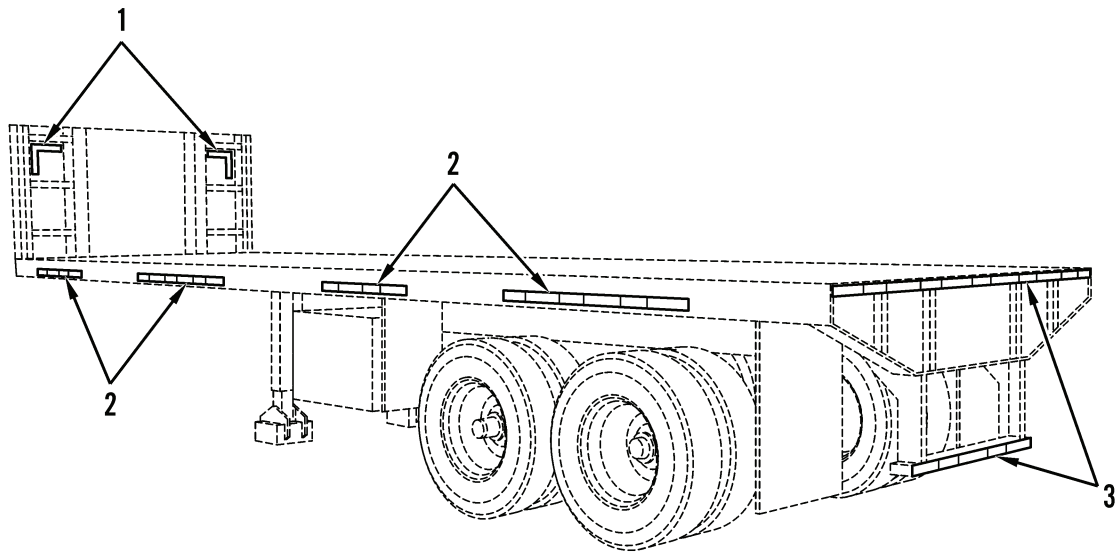

Figure 36. Reflective Tape.

447-5036

(1) ITEM NO	(2) SMR CODE	(3) NSN	(4) CAGEC	(5) PART NUMBER	(6) DESCRIPTION AND USABLE ON CODES (UOC)	(7) QTY
-------------------	--------------------	------------	--------------	-----------------------	--	------------

GROUP 2202 ACCESSORY ITEMS

FIG. 36 REFLECTIVE TAPE

1	MOOZZ		3DGR3	51457017-AR	TAPE, REFLECTIVE WHITE, 12" LG MAKE FROM TAPE NSN 9390-01-509-0712.....	V
2	MOOZZ		13548	98101-AR	TAPE, REFLECTIVE RED/WHITE, (40 FT.) MAKE FROM TAPE NSN 9390-01-504-6185.....	V
3	MOOZZ		13548	98107-AR	TAPE, REFLECTIVE RED/WHITE, (40 FT.) MAKE FROM TAPE NSN 9390-01-504-6187.....	V

END OF FIGURE

1

2

SEMITRAILER, FLATBED BREAKBULK/CONTAINER TRANSPORTER, 22 1/2 TON, M871A2R

C.G.W. & C.G.H. BASED ON SPEED LIMITATION 5300# @ 55 MPH
 C.G.W. TIME PRESSURE 80 PSI COLD TIRE @ WITH 11 RDS 35 PSI RY

THIS VEHICLE CONFORMS TO ALL APPLICABLE FEDERAL MOTOR VEHICLE SAFETY STANDARDS IN EFFECT ON THE DATE OF MANUFACTURE

LIFTING DATA		WEIGHT DISTRIBUTION	
ALL CARGO IN EITHER THE CENTER OR CONTAINER BODY MUST BE EVENLY DISTRIBUTED ON TRAILER PROCEED VERTICAL COMPONENT OF LIFT IN FORCE & MOMENT		EMPTY	LOADED (MAX)
AXLES	8140	35550	
LANDING GEAR	4420	50000	
WHEELS	2570	25000	

MAX SLING HEIGHT - 24
 MAXIMUM VERTICAL CAPACITY - 18000 LBS
 MAXIMUM ANGLE OF LIFT - 45 DEGREES

TIE DOWN DATA
 VEHICLE IS DOWN ON WHEELS CAN BE USED IN ANY DIRECTION
 MAX ANGLE OF TIE DOWN - 45 DEGREES MAXIMUM PROCEED CAPACITY - 6000 LBS
 CARGO TIE DOWN RINGS EXCEED AT 10000 LBS

DATE OF MANUFACTURE: _____ MFGD BY: DYNAWELD, INC.
 CONTRACT: DAAE69AB-0106
 VEHICLE REG. NO. _____ 25W414 N. AMHORA RD.
 NAPERVILLE, ILL 60563

RESET BY: FONTAINE TRAILER MILITARY PRODUCTS
 100 FONTAINE RD. PRINCETON, NY 08859

SERIAL NO. _____

3

2

SEMITRAILER, FLATBED, BREAKBULK/CONTAINER TRANSPORTER, 22 1/2 TON, M871A1

C.G.W. & C.G.H. BASED ON SPEED LIMITATION 5300# @ 55 MPH
 C.G.W. TIME PRESSURE 80 PSI COLD TIRE @ WITH 11 RDS 35 PSI RY

THIS VEHICLE CONFORMS TO ALL APPLICABLE FEDERAL MOTOR VEHICLE SAFETY STANDARDS IN EFFECT ON THE DATE OF MANUFACTURE SHOWN BELOW

LIFTING DATA		WEIGHT DISTRIBUTION DATA	
ALL CARGO IN EITHER THE CENTER OR CONTAINER BODY MUST BE EVENLY DISTRIBUTED ON TRAILER PROCEED VERTICAL COMPONENT OF LIFT IN FORCE & MOMENT		LOCATION	DATA
AXLES	8112	35112	35112
LANDING GEAR	4412	49112	49112
WHEELS	2570	24576	24576

TIE DOWN DATA
 VEHICLE IS DOWN ON WHEELS CAN BE USED IN ANY DIRECTION
 MAX ANGLE OF TIE DOWN - 45 DEGREES MAXIMUM PROCEED CAPACITY - 6000 LBS
 CARGO TIE DOWN RINGS EXCEED AT 10000 LBS

DATE OF MANUFACTURE: _____ MFGD BY: DYNAWELD, INC.
 CONTRACT: DAAE69AB-0106
 VEHICLE REG. NO. _____ 25W414 N. AMHORA RD.
 NAPERVILLE, ILL 60563

RESET BY: FONTAINE TRAILER MILITARY PRODUCTS
 100 FONTAINE RD. PRINCETON, NY 08859

SERIAL NO. _____

LUBRICATION CHART
 SEMI-TRAILER, FLATBED, 22.5 TON
 M871R, M871A1R, M871A2R

WHEEL BEARINGS
 6,000 MILES OR 6 MONTHS
 AND 12,000 MILES OR 1 YEAR
 GAA PER MIL-G-10924G

CAM SHAFT
 6 MONTHS
 GAA PER MIL-G-10924G
 2 PLACES EACH SHAFT

SLACK ADJUSTERS
 6 MONTHS
 GAA PER MIL-G-10924G
 EACH SLACK ADJUSTER

4

2

SEMITRAILER, FLATBED BREAKBULK/CONTAINER TRANSPORTER, 22 1/2 TON, M871R

C.G.W. & C.G.H. BASED ON SPEED LIMITATION 5300# @ 55 MPH
 C.G.W. TIME PRESSURE 80 PSI COLD TIRE @ WITH 11 RDS 35 PSI RY

THIS VEHICLE CONFORMS TO ALL APPLICABLE FEDERAL MOTOR VEHICLE SAFETY STANDARDS IN EFFECT ON THE DATE OF MANUFACTURE

LIFTING DATA		WEIGHT DISTRIBUTION	
ALL CARGO IN EITHER THE CENTER OR CONTAINER BODY MUST BE EVENLY DISTRIBUTED ON TRAILER PROCEED VERTICAL COMPONENT OF LIFT IN FORCE & MOMENT		EMPTY	LOADED (MAX)
AXLES	7770	35550	
LANDING GEAR	4420	50000	
WHEELS	2570	25000	

TIE DOWN DATA
 VEHICLE IS DOWN ON WHEELS CAN BE USED IN ANY DIRECTION
 MAX ANGLE OF TIE DOWN - 45 DEGREES MAXIMUM PROCEED CAPACITY - 6000 LBS
 CARGO TIE DOWN RINGS EXCEED AT 10000 LBS

DATE OF MANUFACTURE: _____ MFGD BY: DYNAWELD, INC.
 CONTRACT: DAAE69AB-0106
 VEHICLE REG. NO. _____ 25W414 N. AMHORA RD.
 NAPERVILLE, ILL 60563

RESET BY: FONTAINE TRAILER MILITARY PRODUCTS
 100 FONTAINE RD. PRINCETON, NY 08859

SERIAL NO. _____

7

8

5

WARNING

SAFETY ALERT! (1) FOLLOW ALL TORQUE REQUIREMENTS. (2) DO NOT USE ANY COMPONENT WITH VISIBLY WORN OR DAMAGED THREADS. FAILURE TO FOLLOW THESE SAFETY ALERTS CAN LEAD TO LOSS OF VEHICLE CONTROL, PROPERTY DAMAGE, SERIOUS PERSONAL INJURY OR DEATH.

Hutchens Suspension Torque Requirements
 800-440 Series (Decal Part Number 10067-01 Rev. E)

After an initial break in period, approximately 1000 miles, and at least every 4 months periodically thereafter, ALL bolts and nuts should be checked to insure that recommended torque values are being maintained.

Oiled torque values listed are for new fasteners with lubricated threads. It is recommended that new installations be performed with oiled fasteners. For dry threads which have been in service, use the higher torque values which are noted below.

	OILED	DRY
1 1/8-12 UNF.	670 lb-ft	880 lb-ft
1-14 UNF.	640 lb-ft	730 lb-ft
7/8-14 UNF.	500 lb-ft	670 lb-ft
3/4-16 UNF.	220 lb-ft	300 lb-ft
5/8-18 UNF.	130 lb-ft	160 lb-ft

HUTCH Hutchens Industries, Inc., P.O. Box 1427, Springfield, Missouri 65801-1427 Toll Free 1 (800) 654-8824

WARNING

1. Read and understand this warning and the installation, Service and Safety Instruction Manual to understand all safety precautions, proper operation, and maintenance of your Webb hub. Failure to do so could result in death or serious injury and could result in a compromise of your vehicles safe operation through loss or failure of a wheel or the compromise of the braking system. Copies of the installation, Service and Safety Instruction Manual are available, free of charge, from Webb Wheel Products, Inc., upon request.

2. Always use a properly calibrated torque wrench to assure proper torque. Under torque and over torque can cause thread and/or nut damage and could result in the loss of a wheel. Failure to ensure proper torque could result in death or serious injury and could shorten the expected life of this product.

3. Recheck torque after the first 50 to 100 miles of service. Parts may seat naturally, causing the torque to drop. A drop in torque could result in the loss of a wheel. Proper torque is essential to avoid damage or compromise of your vehicles safety. Failure to ensure proper torque could result in death or serious injury.

WEBB Webb Wheel Products
 3310 INDUSTRIAL DRIVE, S.W.
 CULLMAN, ALABAMA 36855
 256-739-6660 WWW.WEBBWHEEL.COM

HUBS
 (FOR PILOT MOUNTED DISC WHEELS)
 8 - 10 STUD HUBS
 APPLIES TO M22 X 1.5 STUDS / TWO PIECE FLANGE NUT.

All threads are right hand metric.

Tighten Flange Nuts to 50 ft. lb. using sequence shown.

Check Disc-Wheels for proper positioning on pads and proper seating against flange.

Tighten Flange Nuts to recommended torque using sequence shown.

RECOMMENDED TORQUE: 450 - 500 FT. LBS.

Figure 37. Data Plates (Sheet 1 of 2).

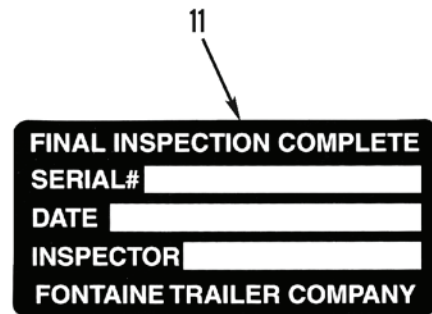

Figure 37. Data Plates (Sheet 2 of 2).

(1) ITEM NO	(2) SMR CODE	(3) NSN	(4) CAGEC	(5) PART NUMBER	(6) DESCRIPTION AND USABLE ON CODES (UOC)	(7) QTY
GROUP 2210 DATA PLATES AND INSTRUCTION HOLDERS						
FIG. 37 DATA PLATES						
1	PFOZZ	7690015563420	0FBD6	50976054	MAKER, IDENTIFICATIO..... UOC:SJB	1
2	PFOZZ	5320008503282	81349	M24243/1-A408	RIVET, BLIND.....	16
3	PFOZZ	7690015563415	0FBD6	50976055	MAKER, IDENTIFICATIO..... UOC:SCB	1
4	PFOZZ	7690014994257	0FBD6	50976003	MARKER, IDENTIFICATI..... UOC:SCB, SKB	1
4	PFOZZ	7690014994258	0FBD6	50976051	MARKER, IDENTIFICATI TIE DOWN..... UOC:SKB	1
5	PFOZZ	7690014993759	92967	16087-1	MARKER, IDENTIFICATI SUSPENSION TORQUE.....	1
6	PFOZZ	7690015562648	18889	SD002C	PLATE, IDENTIFICATIO.....	1
7	PFOZZ	7690015564209	0FBD6	50976005	LABEL, UID.....	2
8	PFOZZ		3DGR3	50976052	PLATE, INSTRUCTION LUBRICATION.....	1
9	PFOZZ	9905015572549	3DGR3	50506050	PLATE, INSTRUCTION AXLE GROSS WEIGHT	1
10	PFOZZ	9905015572550	3DGR3	50507065	PLATE, INSTRUCTION SLACK ADJUSTMENT.	1
11	PFOZZ	7690014994261	0FBD6	50507096	MARKER, IDENTIFICATI.....	1
12	PFOZZ	7690014994259	3DGR3	50507098	MARKER, IDENTIFICATI ANNUAL INSPECTION.....	1

END OF FIGURE

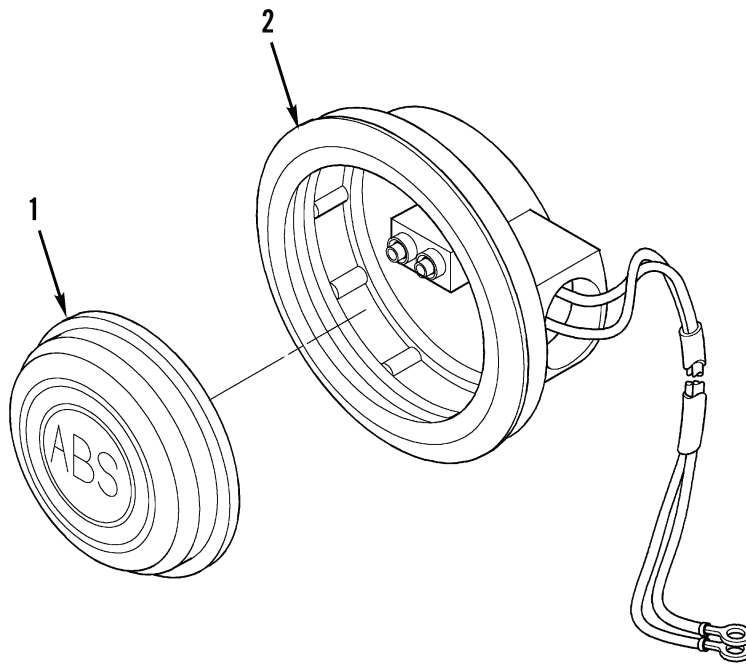

Figure 38. ABS Warning Light.

(1) ITEM NO	(2) SMR CODE	(3) NSN	(4) CAGEC	(5) PART NUMBER	(6) DESCRIPTION AND USABLE ON CODES (UOC)	(7) QTY
-------------------	--------------------	------------	--------------	-----------------------	--	------------

GROUP 42 ELECTRICAL EQUIPMENT

GROUP 4209 SIGNALING DEVICES

FIG. 38 ABS WARNING LIGHT

1	PFOZZ	6240014994267	13548	30257Y	LAMP, INCANDESCENT ABS LAMP.....	1
2	PFOZZ	5325014993619	0FBD6	50824014	GROMMET, NONMETALLIC.....	1

END OF FIGURE

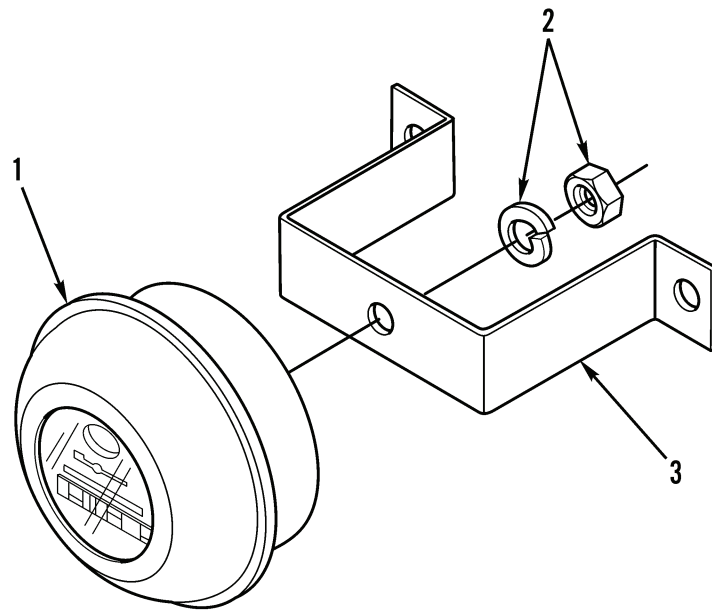

Figure 39. HUBODOMETER®.

447-5039

(1) ITEM NO	(2) SMR CODE	(3) NSN	(4) CAGEC	(5) PART NUMBER	(6) DESCRIPTION AND USABLE ON CODES (UOC)	(7) QTY
-------------------	--------------------	------------	--------------	-----------------------	--	------------

GROUP 47 GAGES (NON-ELECTRICAL), WEIGHTING
AND MEASURING DEVICES

GROUP 4701 INSTRUMENTS

FIG. 39 HUBODOMETER®

1	PFOZZ	6680015562589	3DGR3	50886021	ODOMETER.....	1
2	PFOZZ	5310014993654	26151	641-0004	.NUT, PLAIN, ASSEMBLED.....	1
3	PFOZZ	2590014500304	26151	610-0065	BRACKET, VEHICULAR C.....	1

END OF FIGURE

(1) ITEM NO	(2) SMR CODE	(3) NSN	(4) CAGEC	(5) PART NUMBER	(6) DESCRIPTION AND USABLE ON CODES (UOC)	(7) QTY
GROUP 94 REPAIR KITS						
GROUP 9401 REPAIR KITS						
FIG. KITS						
PFOZZ	2530015518601	78500	KIT8078		PARTS KIT, BRAKE ADJ PARTS FOR ONE END OF AXLE.....	1
					GASKET (2) 7-3	
					PARTS KIT, BRAKE ADJ (1) 7-12	
					RETAINER, ARM BUSHIN (1) 7-4	
					RING, RETAINING (1) 7-7	
					RING, RETAINING (1) 7-19	
					SCREW, TAPPING (4) 7-5	
					SCREW, TAPPING (4) 7-16	
					WASHER, FLAT (1) 7-6	
					WASHER, FLAT (2) 7-18	
					WASHER, RECESSED (1) 7-2	
PFOZZ	2530014969836	78500	KSR2024707QP		PARTS KIT, SHOE BRAK PARTS FOR ONE AXLE.....	1
					BUSHING, ANCHOR PIN (4) 8-8	
					CLIP, SPRING TENSION (4) 8-5	
					PIN, RETURN SPRING (4) 8-3	
					PIN, SHOULDER, HEADLE (4) 8-7	
					ROLLER, LINEAR-ROTAR (4) 8-4	
					SHOE AND LINING ASS (4) 8-1	
					SPRING, HELICAL, EXTE (4) 8-2	
					SPRING, HELICAL, COMP (2) 8-6	
PFOZZ	2590014993446	78502	427-10563		PARTS KIT, BRACKET, V 2 KITS REQUIRED PER AXLE.....	1
					BRACKET, MOUNTING (4) 9-5	
					NUT, PLAIN, EXTENDED (4) 9-4	
PFOZZ	2530014993440	78502	427-10558		PARTS KIT, SHOE BRAK.....	1
					BRACKET, MOUNTING (4) 9-5	
					BUSHING, NONMETALLIC (4) 9-2	
					NUT, PLAIN, EXTENDED (4) 9-4	
					STANDOFF, THREADED, S (4) 9-3	

END OF FIGURE

(1) ITEM NO	(2) SMR CODE	(3) NSN	(4) CAGEC	(5) PART NUMBER	(6) DESCRIPTION AND USABLE ON CODES (UOC)	(7) QTY
-------------------	--------------------	------------	--------------	-----------------------	--	------------

GROUP 95 GENERAL USE STANDARDIZED PARTS

GROUP 9501 HARDWARE SUPPLIES AND BULK
MATERIEL, COMMON

FIG. BULK

1	PFOZZ	4720012879313	61424	PFT-6B-RED	HOSE, NONMETALLIC 3/8" RED.....	1
2	PFOZZ	9390014703620	13548	98101	TAPE, REFLECTIVE RED/WHITE (40 FEET REQUIRED).....	V
3	PFOZZ	9390015090712	0FBD6	51457017	TAPE, REFLECTIVE WHITE.....	V
4	PFOZZ	9390015046187	13548	98107	TAPE, REFLECTIVE RED/WHITE (40 FEET REQUIRED).....	V
5	PFOZZ	4720012879322	61424	PFT-6B-BLU	TUBING, NONMETALLIC 3/8" BLUE.....	1

END OF FIGURE

FIELD AND SUSTAINMENT MAINTENANCE

NSN AND P/N INDEXES

CROSS-REFERENCE INDEXES

NATIONAL STOCK NUMBER INDEX					
STOCK NUMBER	FIG.	ITEM	STOCK NUMBER	FIG.	ITEM
5310-00-045-3299	1	2	5310-00-814-0673	4	2
5310-00-045-8839	11	6	5310-00-823-8803	34	2
4730-00-050-4203	20	4	5320-00-850-3282	37	2
5310-00-061-4651	27	1	5310-00-880-7744	13	5
5305-00-071-2069	21	12	5310-00-934-9757	1	3
	24	25	5310-00-935-9021	21	3
	27	5		22	1
5305-00-071-2072	21	6		22	8
5305-00-071-2073	34	8	6220-01-088-5915	1	1
5310-00-080-6004	21	10	5330-01-090-2107	17	8
	22	3	4730-01-096-9128	12	1
5310-00-087-7493	21	5		12	17
5305-00-115-9526	24	10	2640-01-098-2029	18	4
4730-00-202-6491	12	10	5306-01-098-7197	26	18
5325-00-204-5061	7	19		26	43
5331-00-205-3583	7	9	5306-01-098-7198	26	11
5310-00-225-6993	24	22	5310-01-098-7236	26	23
5306-00-226-4827	17	13		26	44
5305-00-226-4831	4	3	5310-01-098-7244	26	16
3120-00-255-6042	8	8		26	41
5310-00-261-7340	7	15	5310-01-098-7245	26	6
5305-00-269-3217	24	3		26	35
5310-00-269-4040	34	1	5310-01-098-7246	26	22
4730-00-277-8257	12	7		26	45
5325-00-279-1248	5	11	5310-01-098-7247	26	4
5325-00-290-0074	5	12		26	48
3110-00-293-8997	17	3	5310-01-098-7827	26	7
3110-00-293-8998	17	1		26	36
3120-00-322-6430	8	4	2510-01-100-7167	26	13
5310-00-407-9566	17	14		26	34
4730-00-469-7797	12	9	2590-01-100-9001	26	12
5310-00-488-3889	21	9		26	38
	34	5	2510-01-100-9270	26	15
5305-00-543-4372	22	7		26	40
2640-00-555-2823	18	2	2520-01-101-0935	26	19
5310-00-584-5272	27	6		26	31
3110-00-618-0248	17	7	2520-01-101-2551	26	21
3110-00-618-0249	17	4		26	33
5310-00-637-9541	22	2	2510-01-101-2559	26	10
5305-00-724-6761	34	4		26	46
5305-00-724-7222	24	11	2510-01-101-2890	26	14
	27	3		26	39
5305-00-725-2317	22	4	5340-01-112-6396	34	3
5305-00-726-2551	26	8	5310-01-126-9404	24	7
	26	37	5315-01-129-6898	8	7
5365-00-753-4865	7	17	5310-01-133-5373	7	18
5310-00-763-8920	34	1	5360-01-158-1974	8	2
5315-00-784-0637	8	3	4730-01-164-3365	12	5
5310-00-809-5997	24	23	5310-01-174-0431	24	6
	34	7	5340-01-175-0564	24	8

CROSS-REFERENCE INDEXES

NATIONAL STOCK NUMBER INDEX					
STOCK NUMBER	FIG.	ITEM	STOCK NUMBER	FIG.	ITEM
5340-01-209-6524	20	1	6150-01-499-3289	5	2
5306-01-222-9071	20	9	6150-01-499-3311	5	3
5935-01-224-1226	12	3	6150-01-499-3315	5	4
5340-01-239-0890	21	4	5310-01-499-3318	24	18
4710-01-240-9431	26	5	6150-01-499-3320	5	5
	26	29	6150-01-499-3321	5	6
2590-01-241-6060	22	5	6150-01-499-3323	5	7
5310-01-251-7570	20	8	6150-01-499-3327	5	8
2590-01-260-0219	20	5	6150-01-499-3328	5	9
5340-01-264-1579	34	3	6150-01-499-3329	5	10
4730-01-283-1877	12	12	6150-01-499-3332	5	1
4720-01-287-9313	BULK	1	5305-01-499-3342	2	2
4720-01-287-9322	BULK	5	6220-01-499-3350	3	1
2530-01-311-8410	7	12	4730-01-499-3360	14	6
5365-01-314-6592	21	2	5325-01-499-3362	5	13
2590-01-315-2610	22	6	5310-01-499-3372	7	6
5305-01-315-3563	7	16	5325-01-499-3380	7	7
2510-01-315-6287	23	1	5310-01-499-3382	7	2
5365-01-316-3300	26	20	4730-01-499-3385	7	13
	26	32	5530-01-499-3386	29	4
5315-01-316-7547	24	9	3120-01-499-3388	7	8
5340-01-317-2657	20	7	5530-01-499-3391	29	3
5340-01-317-9251	34	6	5360-01-499-3396	8	6
5340-01-318-6775	21	7	6150-01-499-3397	11	7
5306-01-321-2386	26	30	2530-01-499-3399	9	1
7520-01-324-3687	33	1	5340-01-499-3404	9	3
5340-01-328-4418	8	5	5340-01-499-3405	9	5
5330-01-328-6090	7	3	4730-01-499-3406	10	1
9905-01-343-1011	35	3	4810-01-499-3407	10	2
5306-01-347-5921	26	3	5365-01-499-3408	9	2
	26	28	5340-01-499-3409	30	4
9905-01-352-7999	35	1	2540-01-499-3425	32	4
5305-01-359-1367	7	5	5310-01-499-3438	9	4
2530-01-359-8091	7	4	2520-01-499-3439	13	4
4730-01-365-9072	12	4	2530-01-499-3440	KITS	
5305-01-432-1763	21	1	2590-01-499-3446	KITS	
5307-01-440-1364	17	5	5310-01-499-3456	14	2
2530-01-441-9700	18	3		30	1
2530-01-449-9475	17	6	9320-01-499-3458	14	3
2590-01-450-0304	39	3	5310-01-499-3459	7	14
9390-01-470-3620	BULK	2	5310-01-499-3461	14	4
5935-01-480-6241	11	1		30	2
6220-01-482-5320	2	6	5305-01-499-3465	14	5
6220-01-482-5444	2	4		30	5
6220-01-482-5574	2	1	4730-01-499-3471	16	3
6220-01-482-6113	2	1		16	5
2530-01-496-9836	KITS		2530-01-499-3476	17	2
4820-01-497-8729	15	3	5340-01-499-3481	11	10
2530-01-499-3135	7	1	5330-01-499-3487	17	10
2530-01-499-3170	11	8	5310-01-499-3489	18	1

CROSS-REFERENCE INDEXES

STOCK NUMBER	NATIONAL STOCK NUMBER INDEX		STOCK NUMBER	FIG.	ITEM
	FIG.	ITEM			
4720-01-499-3490	12	6	2590-01-499-5434	24	2
5340-01-499-3618	8	11	2590-01-499-5437	24	5
5325-01-499-3619	38	2	5340-01-499-5543	24	13
2530-01-499-3629	14	1	5315-01-499-5545	24	14
4820-01-499-3653	14	7	5320-01-499-5546	24	16
5310-01-499-3654	39	2		28	6
4730-01-499-3663	15	1	2530-01-499-5547	24	17
5310-01-499-3682	32	3	5340-01-499-5549	25	3
5310-01-499-3687	32	2		25	5
4730-01-499-3709	12	14	5305-01-499-5551	2	3
5340-01-499-3717	12	13		3	2
2530-01-499-3718	24	12		11	2
7690-01-499-3759	37	5		16	1
2510-01-499-3799	28	2		16	10
5340-01-499-4157	28	5		21	14
5305-01-499-4202	24	21		35	2
5360-01-499-4204	26	9	2540-01-499-5553	25	4
	26	47	4010-01-499-7594	24	15
5310-01-499-4209	26	17		28	7
	26	42	2510-01-499-7636	28	3
5310-01-499-4211	26	25	2510-01-499-7638	28	1
	26	50	5305-01-499-7657	31	15
5305-01-499-4217	26	2		31	28
	26	27	5305-01-499-7665	32	1
4030-01-499-4227	25	2	2530-01-504-2552	13	1
	25	7	5310-01-504-6159	33	2
2540-01-499-4246	30	3	9390-01-504-6187	BULK	4
5340-01-499-4251	25	1	5330-01-504-8610	16	6
5310-01-499-4253	33	3	5330-01-504-8614	16	4
5305-01-499-4256	33	4	9390-01-509-0712	BULK	3
7690-01-499-4257	37	4	5325-01-514-9957	20	2
7690-01-499-4259	37	12	2510-01-521-2739	31	16
7690-01-499-4261	37	11	2510-01-521-4208	31	27
6240-01-499-4267	38	1	2510-01-521-4213	31	20
4730-01-499-4270	10	3	2510-01-521-4217	31	21
	12	11	2510-01-521-4228	31	22
	14	8	2510-01-521-4230	31	23
	15	2	2510-01-521-4232	31	25
5315-01-499-4271	24	19	2510-01-521-4245	31	26
5310-01-499-4273	24	20	2510-01-521-4248	31	17
	26	24	2510-01-521-4252	31	18
	26	49	2510-01-521-4255	31	19
2510-01-499-4290	20	3	2510-01-521-4399	31	24
4010-01-499-5145	25	6	2510-01-521-8635	23	1
2520-01-499-5403	6	1	5220-01-521-8643	23	2
2530-01-499-5407	8	1	2590-01-522-2672	11	3
5310-01-499-5412	13	2	2541-01-531-4064	21	8
5310-01-499-5416	13	3	2590-01-532-8937	21	11
	17	9	5305-01-551-4703	11	4
2530-01-499-5421	17	11	2530-01-551-8601	KITS	

CROSS-REFERENCE INDEXES

STOCK NUMBER	NATIONAL STOCK NUMBER INDEX		STOCK NUMBER	FIG.	ITEM
	FIG.	ITEM			
5340-01-551-8607	16	7	5510-01-558-8397	31	7
3120-01-552-7425	7	10	5510-01-558-8489	31	13
5310-01-552-7435	11	5	5510-01-558-8545	31	8
2590-01-556-1200	24	24	5510-01-558-8572	31	12
2590-01-556-1271	7	11	5510-01-558-8767	31	4
2590-01-556-1273	32	6	2610-01-558-8770	19	1
5530-01-556-1274	29	6	5510-01-558-9542	31	6
2590-01-556-1276	24	24	5510-01-558-9549	31	10
5310-01-556-1277	16	11	5510-01-559-0830	31	9
2510-01-556-1279	27	4	5510-01-559-0836	31	5
2590-01-556-1332	24	1	5510-01-559-0847	31	14
2590-01-556-1346	24	26	2530-99-782-3392	11	9
2590-01-556-1385	32	6			
2510-01-556-1390	28	4			
5325-01-556-1398	2	7			
5310-01-556-1400	8	9			
5330-01-556-1405	32	5			
5305-01-556-1408	24	2			
5305-01-556-1411	8	12			
4730-01-556-1415	16	12			
4730-01-556-1420	12	17			
4730-01-556-1422	12	17			
4730-01-556-1425	12	15			
4730-01-556-1426	12	5			
5340-01-556-1428	21	13			
2590-01-556-1440	24	26			
2510-01-556-1448	29	1			
6130-01-556-1480	4	1			
2530-01-556-1664	16	8			
2590-01-556-1718	24	4			
5510-01-556-1819	31	2			
2510-01-556-1934	29	5			
2510-01-556-1938	29	2			
2590-01-556-2068	24	1			
2590-01-556-2096	2	5			
4720-01-556-2134	12	16			
5310-01-556-2138	27	2			
6680-01-556-2589	39	1			
7690-01-556-2648	37	6			
7690-01-556-3415	37	3			
7690-01-556-3420	37	1			
7690-01-556-4209	37	7			
5310-01-556-9152	24	5			
4730-01-557-1926	16	9			
9905-01-557-2549	37	9			
9905-01-557-2550	37	10			
5340-01-557-8520	16	2			
5510-01-558-8143	31	3			
5510-01-558-8144	31	11			
2510-01-558-8153	31	1			

CROSS-REFERENCE INDEXES

CAGEC	PART NUMBER	PART NUMBER INDEX		FIG.	ITEM
			STOCK NUMBER		
63900	A-100-VC-8		2640-01-098-2029	18	4
78500	A-3105-K-219		3120-01-552-7425	7	10
3D6E9	A-3105-L-1078		2530-01-359-8091	7	4
78500	A-3299-T-5844		2590-01-556-1271	7	11
3D6E9	AMP43726		4730-01-499-3406	10	1
81343	AS15001-1		4730-00-050-4203	20	4
3D6E9	A3105-V-282		2530-01-311-8410	7	12
06CB9	BF90M45XXZNXX		5340-01-318-6775	21	7
80204	B1821BH031C100N		5306-00-226-4827	17	13
80204	B1821BH031C150N		5305-00-226-4831	4	3
80204	B1821BH038C075D		5305-00-115-9526	24	10
80204	B1821BH038C075N		5305-00-543-4372	22	7
80204	B1821BH038C150N		5305-00-725-2317	22	4
80204	B1821BH050C150N		5305-00-071-2069	21	12
80204	B1821BH050C150N		5305-00-071-2069	24	25
80204	B1821BH050C150N		5305-00-071-2069	27	5
80204	B1821BH050C225N		5305-00-071-2072	21	6
80204	B1821BH050C250N		5305-00-071-2073	34	8
80204	B1821BH063C200N		5305-00-724-7222	24	11
80204	B1821BH063C200N		5305-00-724-7222	27	3
80204	B1821BH063F200N		5305-00-726-2551	26	8
80204	B1821BH063F200N		5305-00-726-2551	26	37
01212	B370025BG2		5330-01-090-2107	17	8
92967	B893-02		4710-01-240-9431	26	5
92967	B893-02		4710-01-240-9431	26	29
80201	C/R1343		2530-01-499-5421	17	11
99411	CP0540		2530-01-499-5421	22	10
99411	CP3473		2590-01-315-2610	22	6
80201	CR453969		2590-01-315-2610	17	12
81348	FF-B-171/01-652		3110-00-618-0249	17	4
94658	F187-20-8		5365-01-314-6592	21	2
94658	F804-1-3		5325-01-514-9957	20	2
94658	F804-1-4		2510-01-499-4290	20	3
60038	HM212011		3110-00-293-8997	17	3
60038	HM212049		3110-00-293-8998	17	1
60038	HM218248		3110-00-618-0248	17	7
78500	KIT8078		2530-01-551-8601	KITS	
74410	KP-AAR-4		2510-01-521-8635	23	1
74410	KP-T-809-F		2510-01-315-6287	23	1
78500	KSR2024707QP		2530-01-496-9836	KITS	
99411	LG0070-02		5315-01-316-7547	24	9
99411	LG0083-05		5340-01-175-0564	24	8
98278	MCDM1-31SS		5935-01-224-1226	12	3
96906	MS27183-13		5310-00-087-7493	21	5
96906	MS27183-14		5310-00-080-6004	21	10
96906	MS27183-14		5310-00-080-6004	22	3
96906	MS27183-17		5310-00-809-5997	24	23
				34	7

CROSS-REFERENCE INDEXES

CAGEC	PART NUMBER	PART NUMBER INDEX		FIG.	ITEM
			STOCK NUMBER		
96906	MS27183-21		5310-00-823-8803	34	2
80205	MS35338-42		5310-00-045-3299	1	2
80205	MS35338-45		5310-00-407-9566	17	14
80205	MS35338-48		5310-00-584-5272	27	6
96906	MS35489-103		5325-00-279-1248	5	11
96906	MS35489-109		5325-00-290-0074	5	12
80205	MS35649-282		5310-00-934-9757	1	3
96906	MS51943-35		5310-00-935-9021	21	3
96906	MS51943-35		5310-00-935-9021	22	1
96906	MS51943-35		5310-00-935-9021	22	8
96906	MS51943-39		5310-00-488-3889	21	9
96906	MS51943-39		5310-00-488-3889	34	5
96906	MS51967-20		5310-00-763-8920	34	1
96906	MS51967-5		5310-00-880-7744	13	5
80205	MS90725-167		5305-00-724-6761	34	4
80205	MS90725-67		5305-00-269-3217	24	3
81349	M24243/1-A408		5320-00-850-3282	37	2
81349	M45913/1-10CG5C		5310-00-269-4040	34	1
81349	M45913/1-10CG8C		5310-00-061-4651	27	1
81349	M45913/1-8CG5C		5310-00-225-6993	24	22
81349	M45913/3-5CG8C		5310-00-814-0673	4	2
8N013	M871-A1-A		5510-01-556-1819	31	2
8N013	M871-A1-B		5510-01-558-8143	31	3
8N013	M871-A1-C		5510-01-558-8767	31	4
8N013	M871-A1-D		5510-01-559-0836	31	5
8N013	M871-A1-E		5510-01-558-9542	31	6
8N013	M871-A1-F		5510-01-558-8397	31	7
8N013	M871-A1-G		5510-01-558-8545	31	8
8N013	M871-A1-H		5510-01-559-0830	31	9
8N013	M871-A1-J		5510-01-558-9549	31	10
8N013	M871-A1-K		5510-01-558-8144	31	11
8N013	M871-A1-KIT		2510-01-558-8153	31	1
8N013	M871-A1-L		5510-01-558-8572	31	12
8N013	M871-A1-M		5510-01-558-8489	31	13
8N013	M871-A1-N		5510-01-559-0847	31	14
8N013	M871A2-A		2510-01-521-4248	31	17
8N013	M871A2-B		2510-01-521-4252	31	18
8N013	M871A2-C		2510-01-521-4255	31	19
8N013	M871A2-D		2510-01-521-4213	31	20
8N013	M871A2-E		2510-01-521-4217	31	21
8N013	M871A2-F		2510-01-521-4228	31	22
8N013	M871A2-G		2510-01-521-4230	31	23
8N013	M871A2-H		2510-01-521-4399	31	24
8N013	M871A2-J		2510-01-521-4232	31	25

CROSS-REFERENCE INDEXES

CAGEC	PART NUMBER	PART NUMBER INDEX		FIG.	ITEM
			STOCK NUMBER		
8N013	M871A2-K		2510-01-521-4245	31	26
8N013	M871A2-KIT		2510-01-521-2739	31	16
8N013	M871A2-L		2510-01-521-4208	31	27
78500	N3105B210		5340-01-328-4418	8	5
61424	PFT-6B-BLU		4720-01-287-9322	BULK	5
61424	PFT-6B-BLU-AR			12	2
61424	PFT-6B-RED		4720-01-287-9313	BULK	1
61424	PFT-6B-RED-AR			12	8
94658	PH2969-1			20	6
99411	PP0016-03		5310-01-174-0431	24	6
64466	PT1383		6150-01-499-3321	5	6
6T589	RC71-68		5340-01-317-9251	34	6
94658	RK804-1A		2590-01-260-0219	20	5
66788	SAT-18315		5340-01-239-0890	21	4
18889	SD002C		7690-01-556-2648	37	6
66788	SL1000		5340-01-264-1579	34	3
78500	SR2024707QP		2530-01-499-5407	8	1
78500	S2237-Z-1222		5935-01-480-6241	11	1
78500	S3155-L-1234		2590-01-522-2672	11	3
78500	S4005001030		4810-01-499-3407	10	2
78500	S4493641530		6150-01-499-3397	11	7
78500	S4497130300		2530-01-499-3170	11	8
78500	S8997598154		5340-01-499-3481	11	10
83473	TB-20		5340-01-112-6396	34	3
74410	TF-0110		5220-01-521-8643	23	2
99411	TS0002		2590-01-241-6060	22	5
99411	TS0013		2590-01-241-6060	22	9
58536	TY-II/CL2/TR-572		2640-00-555-2823	18	2
60359	UTM-2412		6130-01-556-1480	4	1
93061	VS272NTA-6-6		4730-01-283-1877	12	12
93061	VS279NTA-6-4		4730-01-365-9072	12	4
78500	WA-16		5310-00-261-7340	7	15
3D6E9	WA-36		5310-01-499-3459	7	14
3DGR3	00028263		2590-01-556-1273	32	6
3DGR3	00028264		2590-01-556-1385	32	6
0FBD6	00166005		2540-01-499-3425	32	4
0FBD6	01546002		2530-01-499-3718	24	12
0FBD6	01546003		2530-01-499-5547	24	17
0FBD6	01578006		5315-01-499-5545	24	14
0FBD6	02302044		5340-01-499-5543	24	13
3DGR3	02321502		5310-01-556-2138	27	2
0FBD6	02976010		5310-01-499-3318	24	18
0FBD6	04626004		4010-01-499-5145	25	6
0FBD6	04694005		5530-01-499-3386	29	4

CROSS-REFERENCE INDEXES

CAGEC	PART NUMBER	PART NUMBER INDEX		FIG.	ITEM
			STOCK NUMBER		
0FBD6	04694006		5530-01-499-3391	29	3
0FBD6	04694012		5530-01-556-1274	29	6
3DGR3	04694014		2510-01-556-1938	29	2
3DGR3	04694015		2510-01-556-1934	29	5
0FBD6	04696001		2510-01-499-3799	28	2
0FBD6	04696002		2510-01-499-7636	28	3
0FBD6	04696003		2510-01-499-7638	28	1
3DGR3	04696005		2510-01-556-1390	28	4
3DGR3	05472019			27	7
13548	07406		6220-01-482-6113	2	1
13548	07407		6220-01-482-5574	2	1
0FBD6	07430072		5340-01-499-3409	30	4
0FBD6	07758002		5340-01-499-4251	25	1
0FBD6	07758014		2540-01-499-5553	25	4
78500	10-X-1348		5305-01-315-3563	7	16
78500	10-X-1421		5305-01-359-1367	7	5
92967	10055-00		5360-01-499-4204	26	9
92967	10055-00		5360-01-499-4204	26	47
92967	10060-01		5306-01-098-7197	26	18
92967	10060-01		5306-01-098-7197	26	43
18889	101162		5307-01-440-1364	17	5
92967	10273-00		5310-01-098-7244	26	16
92967	10273-00		5310-01-098-7244	26	41
92967	10376-00		5306-01-347-5921	26	3
92967	10376-00		5306-01-347-5921	26	28
92967	10608-00		2510-01-101-2890	26	14
92967	10608-00		2510-01-101-2890	26	39
3DGR3	10687100		2590-01-556-1200	24	24
3DGR3	10687101		2590-01-556-1346	24	26
3DGR3	10687102		2590-01-556-1276	24	24
3DGR3	10687103		2590-01-556-1440	24	26
10125	110500		4820-01-497-8729	15	3
92967	11513-03		5310-01-499-4209	26	17
92967	11513-03		5310-01-499-4209	26	42
78500	1205-Q-2123		5330-01-328-6090	7	3
78500	1205X726		5331-00-205-3583	7	9
78500	1218-G-85		5315-00-784-0637	8	3
78500	1225-B-496		3120-00-255-6042	8	8
78500	1225-R-1058		3120-01-499-3388	7	8
5A910	12258212		6220-01-088-5915	1	1
78500	1229-B-1848		5310-01-133-5373	7	18
78500	1229-J-868		5365-00-753-4865	7	17
78500	1229-R-4100		5310-01-499-3382	7	2
78500	1229-S-4101		5310-01-499-3372	7	6

CROSS-REFERENCE INDEXES

CAGEC	PART NUMBER	PART NUMBER INDEX		FIG.	ITEM
			STOCK NUMBER		
78500	1229-T-4102		5325-01-499-3380	7	7
78500	1229-X-1116		5325-00-204-5061	7	19
78500	1259-N-274		5315-01-129-6898	8	7
00198	132661		5310-00-637-9541	22	2
92967	16087-1		7690-01-499-3759	37	5
06721	166407		2530-01-504-2552	13	1
78500	1779-R-18		3120-00-322-6430	8	4
64466	17900-086		6150-01-499-3320	5	5
64466	18125-400		6150-01-499-3329	5	10
18889	20231UH3T		2530-01-499-3476	17	2
93061	207ACBH-4		4730-01-164-3365	12	5
93061	209P-6-4		4730-00-202-6491	12	10
78500	21220719			8	10
78500	2210-D-6868		2530-01-499-3135	7	1
78500	2210-E-6869		2530-01-499-3159	7	1
93061	2225P-6		4730-00-469-7797	12	9
3D6E9	2258 Q 615S		5360-01-158-1974	8	2
78500	2258-W-803		5360-01-499-3396	8	6
3D6E9	2297-B-5046		4730-01-499-3385	7	13
92967	23276.01		5365-01-316-3300	26	20
92967	23276.01		5365-01-316-3300	26	32
05SD1	2511		2541-01-531-4064	21	8
64466	25150-028		6150-01-499-3315	5	4
64466	28161-028		6150-01-499-3332	5	1
73195	28408		2530-01-441-9700	18	3
13548	30255R		6220-01-482-5444	2	4
13548	30255Y		6220-01-482-5320	2	6
13548	30257Y		6240-01-499-4267	38	1
13548	30720		2590-01-556-2096	2	5
3DGR3	3229		2530-01-499-3629	14	1
3D6E9	3264-A-1457		5340-01-499-3618	8	11
39428	3919T15		5340-01-499-5549	25	3
39428	3919T15		5340-01-499-5549	25	5
45152	4HA891		5330-01-504-8610	16	6
45152	4HA892		5330-01-504-8614	16	4
0N972	401095		4820-01-499-3653	14	7
78502	409-20002		2530-01-499-3399	9	1
78502	427-10558		2530-01-499-3440	KITS	
78502	427-10563		2590-01-499-3446	KITS	
U6718	441 032 8080		2530-99-782-3392	11	9
0N972	441105		4730-01-499-3471	16	3
0N972	441105		4730-01-499-3471	16	5
0N972	441743		5340-01-551-8607	16	7
78502	443-10204		5310-01-499-3438	9	4

CROSS-REFERENCE INDEXES

CAGEC	PART NUMBER	PART NUMBER INDEX		FIG.	ITEM
			STOCK NUMBER		
06721	443-10318		5340-01-499-3404	9	3
78502	445-10467		5340-01-499-3405	9	5
78502	452-10125		5365-01-499-3408	9	2
80201	453795		5330-01-499-3487	17	10
0FBD6	50045217		2520-01-499-5403	6	1
3DGR3	50104001		4730-01-556-1425	12	15
3DGR3	50104002		4730-01-556-1426	12	5
0FBD6	50170005		5305-01-499-4256	33	4
0FBD6	50172008		5305-01-499-3465	14	5
0FBD6	50172008		5305-01-499-3465	30	5
3DGR3	50172106		5305-01-556-1411	8	12
0FBD6	50173008		5305-01-499-7665	32	1
0FBD6	50174006		5305-01-499-4202	24	21
0FBD6	50174017		5305-01-499-4217	26	2
0FBD6	50174017		5305-01-499-4217	26	27
0FBD6	50450016		4010-01-499-7594	24	15
0FBD6	50450016		4010-01-499-7594	28	7
0FBD6	50462030		5340-01-499-4157	28	5
0FBD6	50462035		4030-01-499-4227	25	2
0FBD6	50462035		4030-01-499-4227	25	7
93061	50487001		4730-01-499-3709	12	14
0FBD6	50491010		5340-01-499-3717	12	13
3DGR3	50501006		4730-01-556-1420	12	17
3DGR3	50506050		9905-01-557-2549	37	9
3DGR3	50507065		9905-01-557-2550	37	10
0FBD6	50507096		7690-01-499-4261	37	11
3DGR3	50507098		7690-01-499-4259	37	12
3DGR3	50720025		4730-01-556-1422	12	17
0FBD6	50822014		2540-01-499-4246	30	3
3DGR3	50823044		4730-01-556-1415	16	12
3DGR3	50823045		4730-01-557-1926	16	9
3DGR3	50823046		2530-01-556-1664	16	8
3DGR3	50823047		5310-01-556-1277	16	11
0FBD6	50824014		5325-01-499-3619	38	2
3DGR3	50824018		5325-01-556-1398	2	7
0FBD6	50824060		5325-01-499-3362	5	13
3DGR3	50851109		6150-01-499-3289	5	2
0FBD6	50866003		4720-01-499-3490	12	6
3DGR3	50866009		4720-01-556-2134	12	16
3DGR3	50886021		6680-01-556-2589	39	1
0FBD6	50890077		2590-01-499-5434	24	2
0FBD6	50890078		2590-01-499-5437	24	5
0FBD6	50920012		6220-01-499-3350	3	1
0FBD6	50976003		7690-01-499-4257	37	4

CROSS-REFERENCE INDEXES

CAGEC	PART NUMBER	PART NUMBER INDEX		FIG.	ITEM
			STOCK NUMBER		
0FBD6	50976005		7690-01-556-4209	37	7
0FBD6	50976051		7690-01-556-4209	37	4
3DGR3	50976052			37	8
0FBD6	50976054		7690-01-556-3420	37	1
0FBD6	50976055		7690-01-556-3415	37	3
3D6E9	50979015		4730-01-499-3663	15	1
0FBD6	50981049		5310-01-499-5416	13	3
0FBD6	50981049		5310-01-499-5416	17	9
0FBD6	50990007		5310-01-499-3489	18	1
0FBD6	50995050		5310-01-499-4253	33	3
0FBD6	50995054		5310-01-499-3456	14	2
0FBD6	50995054		5310-01-499-3456	30	1
0FBD6	50995056		5310-01-499-3682	32	3
0FBD6	50995065		5310-01-499-4273	24	20
0FBD6	50995065		5310-01-499-4273	26	24
0FBD6	50995065		5310-01-499-4273	26	49
3DGR3	50995152		5310-01-556-1400	8	9
0FBD6	51029007		9320-01-499-3458	14	3
0FBD6	51182002		5315-01-499-4271	24	19
0FBD6	51205007		4730-01-499-4270	10	3
0FBD6	51205007		4730-01-499-4270	12	11
0FBD6	51205007		4730-01-499-4270	14	8
0FBD6	51205007		4730-01-499-4270	15	2
0FBD6	51205015		4730-01-499-3360	14	6
0FBD6	51457017		9390-01-509-0712	BULK	3
3DGR3	51457017-AR		9390-01-509-0712	36	1
0FBD6	52050001		5320-01-499-5546	24	16
0FBD6	52050001		5320-01-499-5546	28	6
0FBD6	52100010		5305-01-499-5551	2	3
0FBD6	52100010		5305-01-499-5551	3	2
0FBD6	52100010		5305-01-499-5551	11	2
0FBD6	52100010		5305-01-499-5551	16	1
0FBD6	52100010		5305-01-499-5551	16	10
0FBD6	52100010		5305-01-499-5551	21	14
0FBD6	52100010		5305-01-499-5551	35	2
0FBD6	52100013		5305-01-499-3342	2	2
0FBD6	52116040		5305-01-499-7657	31	15
0FBD6	52116040		5305-01-499-7657	31	28
0FBD6	52125333		2520-01-499-3439	13	4
64466	52302-036		6150-01-499-3327	5	8
3DGR3	52600090		5330-01-556-1405	32	5
1JA34	550		7520-01-324-3687	33	1
0FBD6	55752003		5310-01-504-6159	33	2
0FBD6	55752005		5310-01-499-3461	14	4
				30	2

CROSS-REFERENCE INDEXES

CAGEC	PART NUMBER	PART NUMBER INDEX		FIG.	ITEM
			STOCK NUMBER		
0FBD6	55752007		5310-01-499-3687	32	2
0FBD6	55752009		5310-01-499-4211	26	25
0FBD6	55752009		5310-01-499-4211	26	50
3DGR3	58080045		2590-01-556-1718	24	4
1F926	6		5340-01-317-2657	20	7
81343	6-6 130339B		4730-00-277-8257	12	7
26151	610-0065		2590-01-450-0304	39	3
3DGR3	61000004		2510-01-556-1279	27	4
3DGR3	61000008		4820-01-114-6955	26	1
3DGR3	61000008		4820-01-114-6955	26	26
3DGR3	61000010			24	1
3DGR3	61000034		2590-01-556-2068	24	1
3DGR3	61000035		5305-01-556-1408	24	2
3DGR3	61000036		5310-01-556-9152	24	5
3DGR3	61000048		2590-01-556-1332	24	1
3DGR3	61000051		2510-01-556-1448	29	1
3DGR3	61251004		2590-01-532-8937	21	11
64466	63400-227		6150-01-499-3323	5	7
3DGR3	64014008		5340-01-556-1428	21	13
26151	641-0004		5310-01-499-3654	39	2
3DGR3	65340002		5340-01-557-8520	16	2
18889	66884		2530-01-449-9475	17	6
93061	68NTA-6-6		4730-01-096-9128	12	1
93061	68NTA-6-6		4730-01-096-9128	12	17
64466	72203-012		6150-01-499-3311	5	3
65059	78038-1		5340-01-209-6524	20	1
92967	814-00		2590-01-100-9001	26	12
92967	814-00		2590-01-100-9001	26	38
92967	817-00		5310-01-098-7245	26	6
92967	817-00		5310-01-098-7245	26	35
64466	82100-008		6150-01-499-3328	5	9
92967	835-04		5306-01-321-2386	26	30
92967	836-00		5310-01-098-7236	26	23
92967	836-00		5310-01-098-7236	26	44
92967	837-00		5310-01-098-7246	26	22
92967	837-00		5310-01-098-7246	26	45
92967	841-00		5310-01-098-7827	26	7
92967	841-00		5310-01-098-7827	26	36
92967	891-00		2520-01-101-0935	26	19
92967	891-00		2520-01-101-0935	26	31
92967	895-00		5310-01-098-7247	26	4
92967	895-00		5310-01-098-7247	26	48
92967	898-00		2520-01-101-2551	26	21
				26	33

CROSS-REFERENCE INDEXES

CAGEC	PART NUMBER	PART NUMBER INDEX		FIG.	ITEM
			STOCK NUMBER		
39428	90480A011		5310-01-251-7570	20	8
39428	91251A628		5305-01-432-1763	21	1
39428	91839A006		5310-00-045-8839	11	6
39428	92141A006		5310-01-552-7435	11	5
39428	92196A130		5305-01-551-4703	11	4
7X677	9422297		5310-01-126-9404	24	7
39428	9489T13		5306-01-222-9071	20	9
12195	95283		2610-01-558-8770	19	1
92967	9639-03		5306-01-098-7198	26	11
92967	9640-00		2510-01-101-2559	26	10
92967	9640-00		2510-01-101-2559	26	46
13548	98006R		9905-01-343-1011	35	3
13548	98006Y		9905-01-352-7999	35	1
13548	98101		9390-01-470-3620	BULK	2
13548	98101-AR		9390-01-470-3620	36	2
13548	98107		9390-01-504-6187	BULK	4
13548	98107-AR		9390-01-504-6187	36	3
92967	9934-02		2510-01-100-9270	26	15
92967	9934-02		2510-01-100-9270	26	40
92967	9937-00		2510-01-100-7167	26	13
92967	9937-00		2510-01-100-7167	26	34
06721	9999093		5310-01-499-5412	13	2

CHAPTER 11

SUPPORTING INFORMATION

WARNING

The warnings in this chapter are commercial warnings. These are subject to copyright protection and will not always conform to the Government's standards.

FIELD AND SUSTAINMENT MAINTENANCE
REFERENCES

**General, Forms, Regulations,
Field Manuals, Technical Manuals, Pamphlets and Bulletins,
Miscellaneous Publications, Commercial Manuals**

GENERAL

This work package lists the publications referenced in this manual. DA PAM 25-30, *Consolidated Index of Army Publications and Blank Forms*, should be consulted frequently for the latest changes and revisions and for new publications relevant to material covered in this manual.

FORMS

Recommended Changes to Publications and Blank Forms	DA Form 2028
Recommended Changes to Equipment Technical Publications	DA Form 2028-2
Organizational Control Record for Equipment	DA Form 2401
Equipment Inspection and Maintenance Worksheet	DA Form 2404
Maintenance Request	DA Form 2407
Equipment Log Assembly (Records)	DA Form 2408
Preventive Maintenance Schedule and Record	DD Form 314
Processing and Deprocessing Record for Shipment, Storage and Issue of Vehicles and Spare Engines	DD Form 1397
Report of Discrepancy (ROD)	SF Form 364
Product Quality Deficiency Report	SF Form 368

REGULATIONS

The Army Physical Security Program	AR 190-13
Security of Army Property at Unit and Installation Level	AR 190-51
Environmental Protection and Enhancement	AR 200-1
Dictionary of United States Army Terms	AR 310-25
Authorized Abbreviations, Brevity Codes, and Acronyms	AR 310-50
Accident Reporting and Records	AR 385-40
Prevention of Motor Vehicle Accidents	AR 385-55
Army Logistics Readiness and Sustainability	AR 700-138
Reporting of Product Quality Deficiencies Across Component Lines	AR 702-7
Army Materiel Maintenance Policy and Retail Maintenance Operations	AR 750-1

FIELD MANUALS

NBC Contamination Avoidance	FM 3-3
NBC Protection	FM 3-4
NBC Decontamination.	FM 3-5
Field Behavior of NBC Agents (Including Smoke and Incendiaries).	FM 3-6
Mountain Operations	FM 3-97.6
First Aid	FM 4-25.11
Ammunition Handbook	FM 4-30.13
Route Reconnaissance and Classification	FM 5-170
Vehicle Recovery Operations.	FM 9-43-2
Operation and Maintenance of Ordnance Materiel in Cold Weather (0°F to Minus 65°F).	FM 9-207
General Fabric Repair	FM 10-16
Camouflage	FM 20-3
Manual for the Wheeled Vehicle Driver (Distribution Restricted)	FM 21-305
Training in Units	FM 25-101
Basic Cold Weather Manual	FM 31-70
Northern Operations	FM 31-71
Railway Operating and Safety Rules.	FM 55-21
Army Motor Transport Units and Operations	FM 55-30
Desert Operations (How to Fight)	FM 90-3
Operational Terms and Symbols	FM 101-5-1

TECHNICAL MANUALS

Inspection, Care and Maintenance of Antifriction Bearings	TM 9-214
Welding Theory and Application.	TM 9-237 (1993)
Operator's Unit, Direct Support and General Support, Maintenance Manual for Care, Maintenance Repair and Inspection of Pneumatic Tires and Inner Tubes	TM 9-2610-200-14
Painting Instructions for Army Materiel	TM 43-0139
Railcar Loading Procedures.	TM 55-2200-001-12
Storage and Materials Handling	TM 743-200-1
Procedures for Destruction of Tank-automotive Equipment to Prevent Enemy Use	TM 750-244-6
Direct Support and General Support for Quality Control Inspector's Inspection Criteria	TM 750-245-4

PAMPHLETS AND BULLETINS

The Army Maintenance Management System (TAMMS) User Manual DA PAM 750-8

Tiedown Handbook for Rail Movement MTMCTEA Pam 55-19

Tiedown Handbook for Truck Movement MTMCTEA Pam 55-20

Tiedown Handbook for Fixed Wing Air Movement MTMCTEA Pam 55-24

Storage Serviceability Standard: Tracked Vehicles, Wheeled Vehicles, and Component Parts SB 740-98-1

Towed Wheeled Vehicles, FSC Class 2330, Lunette Trailers and Semitrailers:
 Repair of Frames. TB 9-2510-242-40 (Nov 95)

Equipment Improvement Report and Maintenance Digest (U.S. Army Tank-automotive
 and Armaments Command) Tank and Automotive Equipment TB 43-0001-39 Series

Maintenance Expenditure Limits for Tactical Wheeled Vehicles, FSC Group 23,
 FSC Classes 2320 and 2330 TB 43-0002-81

Color, Marking, and Camouflage Painting of Military Vehicles, Construction Equipment and
 Materials Handling Equipment TB 43-0209

Corrosion Prevention and Control Including Rust Proofing Procedures for Tactical Vehicles
 and Trailers TB 43-0213

Inspection, Use and Tightening of Metal Fasteners Used on Tank-automotive Equipment TB 43-0218

Maintenance in the Desert TB 43-0239

MISCELLANEOUS PUBLICATIONS

Army Medical Department Expendable/Durable Items. CTA 8-100

Expendable/Durable Items (Except Medical, Class V, Repair Parts and Heraldic Items CTA 50-970

Marine Lifting and Lashing Handbook MTMCTEA Ref 97-55-22

Vehicle Preparation Handbook for Fixed Wing Air Movement MTMCTEA Ref 97-55-24

COMMERCIAL MANUALS

Meritor Trailer Axle	Manual No. 14, Revised 1-99
Complete Repairs, Tear Down, Cleaning, Welding, Alignment, Lubrication of Axle, Brake Systems and ABS	Call: 1-800-535-5560
Meritor WABCO Easy-Stop Trailer ABS	Maintenance Manual No. 33, Revised 4-98
Basic and Standard ABS Systems (including 4S/2M System on M871A3)	Call: 1-800-535-5560
Rockwell WABCO Blank Code Diagnostic Guide 4S/2M Easy Stop.	TP-0173; Call 1-800-535-5560
Meritor WABCO	
Training Program-Student Manual, Issued 3-98	
Module 1 — Overview & Components	
Module 2 — Diagnosis and Repair	
Easy-Stop Trailer ABS	TP-9812; Call: 1-800-535-5560
Hutchens Industries	Configurations and Parts Identification
900 Single Point Suspension Series.	Call: 1-800-654-8824
Haldex Automatic Brake Adjusters, Service Manual Truck and Trailer Applications	Call: 1-800-821-8469

END OF WORK PACKAGE

FIELD AND SUSTAINMENT MAINTENANCE
MAINTENANCE ALLOCATION CHART (MAC) INTRODUCTION

THE ARMY MAINTENANCE SYSTEM MAC

1. This introduction provides a general explanation of all maintenance and repair functions authorized at the two maintenance levels under the Two-Level Maintenance System concept.
2. The MAC immediately following this introduction designates overall authority and responsibility for the performance of maintenance functions on the identified end item or component. The application of the maintenance functions to the end item or component shall be consistent with the capacities and capabilities of the designated maintenance levels, which are shown in the MAC (WP 0082) in column (4) as:

Field - includes subcolumns:

C - Operator/Crew

O - Unit

F - Direct Support

Sustainment - includes subcolumns:

H - General Support

D - Depot

3. The tools and test equipment requirements (immediately following the MAC) list the tools and test equipment (both special tools and common tool sets) required for each maintenance function as referenced from the MAC.
4. The remarks (immediately following the tools and test equipment requirements) contain supplemental instructions and explanatory notes for a particular maintenance function.

MAINTENANCE FUNCTIONS

Maintenance functions are limited to and defined as follows:

1. **Inspect**. To determine the serviceability of an item by comparing its physical, mechanical, and/or electrical characteristics with established standards through examination (e.g., by sight, sound, or feel).
2. **Test**. To verify serviceability by measuring the mechanical, pneumatic, hydraulic, or electrical characteristics of an item and comparing those characteristics with prescribed standards on a scheduled basis, i.e., load testing of lift devices and hydrostatic testing of pressure hoses.
3. **Service**. Operations required periodically to keep an item in proper operating condition; e.g., to clean (includes decontaminate, when required), preserve, drain, paint, or replenish fuel, lubricants, chemical fluids, or gases.
4. **Adjust**. To maintain or regulate, within prescribed limits, by bringing into proper position, or by setting the operating characteristics to specified parameters.
5. **Align**. To adjust specified variable elements of an item to bring about optimum or desired performance.
6. **Calibrate**. To determine and cause corrections to be made or to be adjusted on instruments of test, measuring, and diagnostic equipment used in precision measurement. Calibration consists of comparisons of two instruments, one of which is a certified standard of known accuracy, to detect and adjust any discrepancy in the accuracy of the instrument being compared.

MAINTENANCE FUNCTIONS - CONTINUED

7. **Remove/Install.** To remove and install the same item when required to perform service or other maintenance functions. Installation may be the act of emplacing or seating a spare, repair part, or module (component or assembly) into position in a manner to allow the proper functioning of an equipment or system.
8. **Replace.** To remove an unserviceable item and install a serviceable counterpart in its place. Replacement is authorized by the MAC and the assigned maintenance level is shown as the third position code of the Source, Maintenance and Recoverability (SMR) code.
9. **Repair.** Repair is the application of maintenance services, including fault location/troubleshooting, removal/installation, disassembly/assembly procedures, and maintenance actions to identify troubles and restore serviceability to an item by correcting specific damage, fault, malfunction, or failure in a part, subassembly, module (component or assembly), end item, or system.

NOTE

The following definitions are applicable to the “repair” maintenance function:

- Services - Inspecting, testing, service, adjustment, alignment, calibration, and/or replacement.
 - Fault location/troubleshooting - The process of investigating and detecting the cause of equipment malfunctioning; the act of isolating a fault within a system or Unit Under Test (UUT).
 - Disassembly/assembly - The step-by-step breakdown (taking apart) of a spare/functional group coded item to the level of its least component, assigned a SMR code for the level of maintenance under consideration (i.e., identified as maintenance significant).
 - Actions - Welding, grinding, riveting, straightening, facing, machining, and/or resurfacing.
10. **Overhaul.** That maintenance effort (service/action) prescribed to restore an item to a completely serviceable/operational condition as required by maintenance standards in appropriate technical publications. Overhaul is normally the highest degree of maintenance performed by the Army. Overhaul does not normally return an item to like new condition.
 11. **Rebuild.** Consists of those services/actions necessary for the restoration of unserviceable equipment to a like new condition in accordance with original manufacturing standards. Rebuild is the highest degree of materiel maintenance applied to Army equipment. The rebuild operation includes the act of returning to zero those age measurements (hours/miles, etc.) considered in classifying Army equipment/components.

EXPLANATION OF COLUMNS IN THE MAC, TABLE 1

1. **Column (1) - Group Number.** Column (1) lists Group numbers, the purpose of which is to identify maintenance significant components, assemblies, subassemblies, and modules with the Next Higher Assembly (NHA).
2. **Column (2) - Component/Assembly.** Column (2) contains the item names of components, assemblies, subassemblies, and modules for which maintenance is authorized.
3. **Column (3) - Maintenance Function.** Column (3) lists the functions to be performed on the item listed in Column (2). (For a detailed explanation of these functions, refer to “Maintenance Functions” outlined above.)

EXPLANATION OF COLUMNS IN THE MAC, TABLE 1 - CONTINUED

4. **Column (4) - Maintenance Level.** Column (4) specifies each level of maintenance authorized to perform each function listed in column (3), by indicating work time required (expressed as manhours in whole hours or decimals) in the appropriate subcolumn. This work time figure represents the active time required to perform that maintenance function at the indicated level of maintenance. If the number or complexity of the tasks within the listed maintenance function varies at different maintenance levels, appropriate work time figures are to be shown for each level. The work time figure represents the average time required to restore an item (assembly, subassembly, component, module, end item, or system) to a serviceable condition under typical field operating conditions. This time includes preparation time (including any necessary disassembly/assembly time), troubleshooting/fault location time, and quality assurance time in addition to the time required to perform the specific tasks identified for the maintenance functions authorized in the MAC. The symbol designations for the various maintenance levels are as follows:

Field:

- C - Operator/Crew Maintenance
- O - Organizational Maintenance
- F - Direct Support Maintenance

Sustainment:

- H - General Support Maintenance
- D - Depot Maintenance

NOTE

The "L" maintenance level is not included in column (4) of the MAC. Functions to this level of maintenance are identified by a work time figure in the "H" column of column (4), and an associated reference code is used in the REMARKS column (6). This code is keyed to the remarks, and the SRA complete repair application is explained there.

5. **Column (5) - Tools and Equipment Reference Code.** Column (5) specifies, by code, common tool sets (not individual tools), common Test, Measurement, and Diagnostic Equipment (TMDE), special tools, special TMDE, and special support equipment required to perform the designated function. Codes are keyed to the entries in the tools and test equipment table.
6. **Column (6) - Remarks Code.** When applicable, this column contains a letter code, in alphabetical order, which is keyed to the remarks table entries (Table 3).

EXPLANATION OF COLUMNS IN THE TOOLS AND TEST EQUIPMENT REQUIREMENTS, TABLE 2

1. **Column (1) - Tool or Test Equipment Reference Code.** The tool and test equipment reference code correlates with a code used in column (5) of the MAC.
2. **Column (2) - Maintenance Level.** The lowest level of maintenance authorized to use the tool or test equipment.
3. **Column (3) - Nomenclature.** Name or identification of the tool or test equipment.
4. **Column (4) - National Stock Number (NSN).** The NSN of the tool or test equipment.
5. **Column (5) - Tool Number.** The manufacturer's part number, model number, or type number.

EXPLANATION OF COLUMNS IN THE REMARKS, TABLE 3

1. **Column (1) - Reference Code.** The code recorded in column (6) of the MAC.
2. **Column (2) - Remarks.** This column lists information pertinent to the maintenance function being performed as indicated in the MAC.

END OF WORK PACKAGE

**FIELD AND SUSTAINMENT MAINTENANCE
MAINTENANCE ALLOCATION CHART (MAC)**

Table 1. Maintenance Allocation Chart (MAC) for M871R Series Trailer.

(1) GROUP NUMBER	(2) COMPONENT/ ASSEMBLY	(3) MAINTENANCE FUNCTION	(4)					(5) TOOLS AND EQUIPMENT	(6) REMARKS
			FIELD			SUSTAINMENT			
			C	O	F	H	D		
06	Electrical System							1,4	C,J,O
0609	Lights, Stop, and Tail, LED (Red)	Inspect Test Remove/Install Replace	0.1	0.3 0.2 0.2					
	Lights, Blackout	Inspect Test Remove/Install Replace	0.1	0.3 0.2 0.2					C,O
	Lights, Marker LED (Amber and Red)	Inspect Test Removal/Install Replace	0.1	0.3 0.1 0.1					C,O
	Lights, Clearance LED (Red)	Inspect Test Remove/Install Replace	0.1	0.2 0.2 0.2					C,O
0613	Wiring Harness (Front or Rear)	Inspect Test Remove/Install Repair	0.2	0.5 1.0 0.5					C,O
	Box, Converter	Inspect Test Remove/Install Replace	0.1	0.1 0.3 0.2 0.5					O
11	Rear Axle							1,3,4	GI
1100	Axle Assembly	Inspect Check Align Replace	0.2	0.2 1.0	2.0 5.0				G
	Seat, Spring	Replace			0.5				Each Seat Spring
	Plate, Adjustment Dust Shield	Replace Replace		0.5					Each Each Shield

Table 1. Maintenance Allocation Chart (MAC) for M871R Series Trailer - Continued.

(1) GROUP NUMBER	(2) COMPONENT/ ASSEMBLY	(3) MAINTENANCE FUNCTION	(4)					(5) TOOLS AND EQUIPMENT	(6) REMARKS
			FIELD			SUSTAIN MENT			
			C	O	F	H	D		
12	Brakes							4,5	B,C,L
1202	Shoe Assembly, Brake	Inspect Test Replace		0.3 0.5 1.5					
	Anchor, Rollers, Retainers, Springs, Bushings, Pins	Inspect Remove/Install Replace		0.5 0.5 0.5					B
	S-Camshaft	Inspect Test Remove/Install Replace		0.2 0.5 0.5 0.7					B
1206	Slack Adjuster, Automatic	Inspect Test Service Adjust Replace Repair	0.2	0.2 0.5 0.1 0.3 0.5 0.3					C
1207	Control Unit, Electronic (ECU) and Module	Inspect Test Replace		0.2 0.5 0.5					J,O
	Sensor, Wheel w/Cable	Inspect Test Adjust Replace		0.1 0.2 0.3 0.3					B,O
	Valve, Modulator	Test Replace		0.1 1.0					J
	Cable, Diagnostic	Test Replace		0.2 0.2					O
	Adapter, Blink Code	Replace		0.1					O
1208	Chamber, Air Brake Long Stroke	Inspect Replace	0.1		1.0				C
	Reservoir, Air	Inspect Service Test Replace	0.1 0.1		0.2 1.5				C
	Valve, Air Drain and Pull Cables	Inspect Replace	0.1		0.3				C
	Valve, Multifunction (SEALCO)	Inspect Test Replace	0.1		0.5 0.5				J

Table 1. Maintenance Allocation Chart (MAC) for M871R Series Trailer - Continued.

(1) GROUP NUMBER	(2) COMPONENT/ ASSEMBLY	(3) MAINTENANCE FUNCTION	(4)					(5) TOOLS AND EQUIPMENT	(6) REMARKS
			FIELD			SUSTAIN MENT			
			C	O	F	H	D		
12	Brakes - Continued								
	Air Supply, Gladhand	Inspect Service Replace Repair	0.1	0.1 0.3 0.2				C	
	Valve, Relay	Inspect Replace	0.1	0.5				J	
	Lines, Air	Inspect Replace	0.1	0.3				C	
13	Wheel Assembly						3,4,5	B,L	
1311	Wheel	Inspect Remove/Install Service Replace	0.1 0.3	0.1 0.2 0.5					
	Hub Caps	Replace		0.5					
	Drum, Brake	Inspect Remove/Install Replace Repair		0.2 0.5 0.5	1.0			B	
	Hubs w/Tone Rings	Inspect Remove/Install Replace		0.2 0.3 0.5				B,J	
	Bearings, Inner/ Outer (Cone Assembly and Hub)	Inspect Service Replace		0.2 0.3 0.5				B	
	Seal, Wheel	Replace		0.3				B,N	
	Spindle Nut, Pro-Torque	Adjust Replace		0.3 0.3					
1313	Tires, Radial, and Spare Assemblies	Inspect Service Remove/Install Replace Repair	0.2 0.2 0.5 0.5	0.5 0.5		1.5			
15	Frame, Towing Attachments						4,7	C,F,I,L,M	
1501	Weld Mounts, Frame	Inspect Repair	0.2	0.3	0.3 3.0	3.0+			

Table 1. Maintenance Allocation Chart (MAC) for M871R Series Trailer - Continued.

(1) GROUP NUMBER	(2) COMPONENT/ ASSEMBLY	(3) MAINTENANCE FUNCTION	(4)					(5) TOOLS AND EQUIPMENT	(6) REMARKS	
			FIELD			SUSTAIN MENT				
			C	O	F	H	D			
15	Frame, Towing Attachments - Continued	Twist Lock Inspect Service Replace Repair	0.1						C	
			0.2							
				0.5	1.5					
				0.6						
		Dock Bumpers, Rubber	Replace		0.3					C
		Cargo Tiedown Deck D-Rings	Inspect Service Replace Repair	0.1	0.1					C
				0.2		0.3				
						0.3				
		Rail/Shipment D-Rings	Inspect Service Replace	0.1	0.1					
				0.2						
						0.8				
		Lift Points	Replace		0.5					C
					0.2					
1503 Kingpin	Inspect Test Service Replace	0.1	0.4					I		
			0.5							
		0.2			3.0					
1504 Carrier, Spare Tire	Inspect Replace Repair	0.1								
			0.5							
				0.5						
1507 Gear, Landing and Shoes	Inspect Service Replace Repair	0.2						C		
		0.1		2.0						
				1.5						
				0.1						
				0.3						
Crank Handle	Replace		0.1							
Ground Boards and Chocks	Replace Repair		0.3					C		
			0.2							
16	Suspension						4,5,7	C,I,K		
1601	Spring Assembly, Leaf	Inspect Adjust Align Replace		0.2	0.2					
				1.5	1.5					
					1.0					
					4.0					
Tube, Trunnion	Inspect Replace Repair		0.2	0.2						
				4.0						
				2.0						

Table 1. Maintenance Allocation Chart (MAC) for M871R Series Trailer - Continued.

(1) GROUP NUMBER	(2) COMPONENT/ ASSEMBLY	(3) MAINTENANCE FUNCTION	(4)					(5) TOOLS AND EQUIPMENT	(6) REMARKS
			FIELD			SUSTAIN MENT			
			C	O	F	H	D		
16	Suspension - Continued								
	Bushings, Polyurethane	Replace			1.5			C	
	Plate, Adjustment	Align Replace			0.5 0.5			C	
	End Cap and Rubber Pad	Inspect Replace	0.1	0.1 0.5				Each	
18	Body						4,10	C,D,E,L	
1801	Flaps, Mud, Antisail	Inspect Replace	0.1		0.3			C	
	Bulkhead	Service Replace Repair	0.2		1.5 1.5 0.3			C	
1805	Decking	Inspect Service Replace	0.2		0.5 4.0			D,E	
1808	Box, Stowage	Inspect Service Replace Repair	0.1 0.1		0.5 0.3				
	Side Panel, Box	Replace			0.7			Weld Each Side Panel	
	Side Board Storage Rack	Service Repair Replace	0.3		0.3 0.5			C	
	Box, Manifest	Replace			0.3				
22	Accessory Items						1,4	C	
2202	Reflectors	Inspect Replace	0.1		0.1				
	Conspicuity Tape	Inspect Replace	0.1		0.1			Each Section	
2210	Plates, Data and Decals	Replace			0.2				
	UID Label	Replace			0.1				

Table 1. Maintenance Allocation Chart (MAC) for M871R Series Trailer - Continued.

(1) GROUP NUMBER	(2) COMPONENT/ ASSEMBLY	(3) MAINTENANCE FUNCTION	(4)					(5) TOOLS AND EQUIPMENT	(6) REMARKS
			FIELD			SUSTAIN MENT			
			C	O	F	H	D		
42 4209	Electrical Equipment Light, Warning, ABS	Inspect Test Replace	0.1	0.2 0.2				1	C,L,O
47 4701	Gages (Non- Electrical) HUBODOMETER®	Replace Remove/Install		0.2 0.2					

Table 2. Tools and Test Equipment for the M871R Series Trailer.

(1) TOOLS OR TEST EQUIPMENT REFERENCE CODE	(2) MAINTENANCE LEVEL	(3) NOMENCLATURE	(4) NATIONAL STOCK NUMBER (NSN)	(5) TOOL NUMBER
1	O	Shop Equipment, Automotive Maintenance and Repair: Organizational Maintenance, Common No.1	4910-00-754-0654	SC 4910-95-CL-A74
2	O	Shop Equipment, Automotive Maintenance and Repair: Organizational Maintenance, Common No.2	4910-00-754-0653	SC 4910-95-CL-A72
3	O,F,H	Shop Equipment, Automotive Maintenance and Repair: Field Maintenance, Basic, Less Power	4910-00-348-7696	SC 4910-95-CL-A31
4	O,F	Tool Kit, General Mechanic's Automotive	5180-00-177-7033	SC 5180-90-CL-N26
5	O,F	Shop Equipment, Automotive Maintenance and Repair	4910-00-754-0705	SC 4910-95-CL-A31
6	O,F	Wheel Bearing Wrench Set	5120-00-196-4586	
7	F	Shop Equipment, Welding, Field Maintenance	3470-00-357-7269	SC 3470-95-CL-A08
8	O	Torque Wrench, 0 to 200 lb-in. (0 to 22.6 Nm)	5120-00-853-4538	
9	O	Torque Wrench, 0 to 600 lb-ft (0 to 813 Nm)	5120-00-221-7983	
10	O	Bit, Hex, Insert, 1/4 in. Drive	5120-01-160-9635	440-TX40
11	O	Socket, 8-Sided, 3-3/4 in., 3/4 in. Drive	5120-01-528-6347	P/N 6KK953 (CAGEC 45152)

Table 3. Remarks for the M871R Series Trailer.

REFERENCE CODE	REMARKS
A	Times are for one axle only.
B	Times are for one axle end only.
C	Times are for each component/assembly.
D	Annual service to UV protect decking.
E	1.5 hours to replace each board.
F	Reference TB 9-2510-242-40.
G	Unit level checks only the axle alignment.
H	Tire is re-treadable, tire is not on a re-tread program.
I	Requires welding.
J	Component comes as an assembly only.
K	New suspension hardware requires wet (oiled) torque values. In-service hardware requires dry torque values.
L	Spot painting, tire air/pressure check, oil can points, and cleaning for all like components.
M	Frame deficiencies need to be evaluated at the DS level to determine the events of repair. Some minor deficiencies may be handled at DS. Major repairs such as cracks and damage that requires alignment must go to GS.
N	A correct size seal drive must be used to prevent damage/cooking of seal. Hub bore must be clean and seal bottomed.
O	Dielectric grease must be used on pins and connectors.

END OF WORK PACKAGE

FIELD AND SUSTAINMENT MAINTENANCE**BASIC ISSUE ITEMS (BII) LIST**

SCOPE

This work package lists Basic Issue Items (BII) for the semitrailer to help you inventory items for safe and efficient operation of the equipment.

GENERAL

BII are required to place the semitrailer in operation, operate it, and do emergency repairs. Although shipped separately packaged, BII must be with the semitrailer during operation and when it is transferred between property accounts. Listing these items is your authority to request/requisition them for replacement based on authorization of the end item by the Table of Organization and Equipment (TOE)/Modified Table of Organization and Equipment (MTOE).

EXPLANATION OF COLUMNS

1. **Column (1)—National Stock Number (NSN).** Identifies the stock number of the item to be used for requisitioning purposes.
2. **Column (2)—Description, Commercial and Government Entity Code (CAGEC), and Part Number (P/N).** Identifies the Federal item name followed by a minimum description when needed. The line below the name and description is the CAGEC (in parentheses), the part number and manufacturer.
3. **Column (3)—Quantity (Qty).** Indicates the quantity of the item authorized to be used with/on the equipment.
4. **Column (4)—Location.** Identifies the location of the item on the semitrailer.

NOTE

- Semitrailers dedicated to ROWPU and LADS do not have side/rear rack assemblies or their storage rack.
- Do not use cross chains when using bows and tarp.
- Except for the diagnostic extension cable, blink code adapter diagnostic tool, side racks/hardware, splices, top rails, stakes, and twist locks, everything else is over-packed in the stowage box. Panels and stakes will be secured in the bulkhead.

Table 1. Basic Issue Items (BII) for the M871R Series Trailer.

(1) NSN	(2) DESCRIPTION, CAGEC, P/N	(3) QTY	(4) LOCATION
5340-01-499-4251	Boards, ground w/attaching hardware: (OFBD6) - 07758002	2	In Side Brackets
4030-01-499-4227	Chain links: (OFBD6) - 50462035	2	In Side Brackets
5340-01-499-5549	Clips: (OFBD6) - 3919775	4	In Side Brackets
5315-01-499-3742	Pins: (OFBD6) - 08796002	2	In Side Brackets
5315-01-499-4271	Pins, cotter: (OFBD6) - 51182002	4	In Side Brackets
5310-01-499-3318	Washers: (OFBD6) - 02976010	4	In Side Brackets
5306-01-500-1994	Bolts, caging: (06721) - 10043, Haldex	4 (for long-stroke air brake chambers)	On Air Chambers
2540-01-377-9255	Chock w/eye hook only (1) (9X737) - WC796R	4	In Stowage Box
2540-01-499-5553	Chock block assembly: (1) (OFBD6) - 07758014	2 blocks, 1 chain, 2 snaps	In Stowage Box
4010-01-499-5145	(OFBD6) - 04626004; chain (1)	2	In Stowage Box
5340-01-499-4157	Link, open, rigid eye: snap hook, zinc plated (1) (OFBD6) - 50462030	4	In Stowage Box
5340-01-499-5562	Cinching straps: (OFBD6) - 50102099	3	In Stowage Box
5935-01-480-6241	Diagnostic adapter and cap, blink code: (78500) - S2237-Z-1222	1 adapter, 1 cap	Rear, Center of Trailer
6150-01-499-5143	Diagnostic cable, extension: (78500) - 449-364-152-0	1	Rear, Center of Trailer
2590-01-500-1997	Jack, 12-ton (10.89-metric ton) w/handles: (OFBD6) - 07758080	1 jack, 2 handles	In Stowage Box
3040-01-499-5565	Pipe extension, 1 in. (2.5-cm), cheater bar: (OFBD6) - 00016016	1	In Stowage Box
Side and corner stake assemblies w/hardware			
2510-01-499-7636	Corner stake assy: (OFBD6) - 04696002	1	Bulkhead Storage
2510-01-K82-6310	Corner stake assy: (OFBD6) - 04696005	1	Bulkhead Storage
2510-01-499-3799	Side stake assy, 53 in. (134.6 cm): (OFBD6) - 04696001 (cross-chain stakes)	4	Bulkhead Storage
2510-01-499-7638	Side stake assy, 53 in. (134.6 cm): (OFBD6) - 04696003	11	Bulkhead Storage
5530-01-499-3386	Side panel (M871R and M871A1R), 35-3/4 x 48 x 1/2 in. (91 x 122 x 1.3 cm): (OFBD6) - 04694005	2	Bulkhead Storage

Table 1. Basic Issue Items (BII) for the M871R Series Trailer - Continued.

(1) NSN	(2) DESCRIPTION, CAGEC, P/N	(3) QTY	(4) LOCATION
5530-01-499-3386 (Cont)	Side panel (M871A2R), 42 x 48 x 1/2 in. (107 x 122 x 1.3 cm): (OFBD6) - 04694015	2	Bulkhead Storage
	Side panel, 23-3/4 x 48 x 1/2 in. (60 x 122 x 1.3 cm): (OFBD6) - 04694014	2	Bulkhead Storage
5530-01-499-3391	Side panel, 47-3/4 x 48 x 1/2 in. (121 x 122 x 1.3 cm): (OFBD6) - 04694006	12	Bulkhead Storage
	Rear panel, 44 x 48 x 1/2 in. (112 x 122 x 1.3 cm) (OFB06) - 04694012	2	Bulkhead Storage
	Side rack cross chains w/hooks		
	Chain assemblies w/hooks: (3DGR3) - S118673X-20	2	In Stowage Box
	Chain assemblies w/hooks (3DGR3) - S118673X-25	2	In Stowage Box
	Complete storage rack assembly w/panels and all hardware		
2510-01-499-4290	Twist lock assemblies: (94658) - F804-1-4	4	On Left and Right Rails
2590-01-062-3520	Container lock with F-pin (55683) 1920-FC7537	4	In Stowage Box
5120-01-170-4980	Wrench, hex handle: (OFBD6) - 50939002	1	In Stowage Box
5120-01-514-3465	Wrench, lug, double-end: (OFBD6) - 50939001	1	In Stowage Box
2541-01-531-4064	Ladder, safety	1	Bulkhead Storage
2590-01-532-8937	Ladder bracket, mounting	1	Installed

END OF WORK PACKAGE

**FIELD AND SUSTAINMENT MAINTENANCE
ADDITIONAL AUTHORIZATION LIST (AAL)**

SCOPE

This work package lists items authorized to you for the support of the semitrailer.

GENERAL

This work package identifies items that do not have to accompany the semitrailer and do not have to be turned in with it. These items are all authorized to you by Common Table of Allowances (CTA), Modified Table of Organization and Equipment (MTOE), Table of Distribution and Allowances (TDA), or Joint Table of Allowances (JTA).

EXPLANATION OF LISTING

National Stock Numbers (NSN), descriptions, and quantity recommended are provided in Table 1 to help you identify and request the additional items you require to support this equipment.

NOTE

Do not use cross chains when using bows and tarps.

Table 1. Additional Authorization List (AAL) for the M871R Series Trailer.

(1) NSN	(2) DESCRIPTION, CAGEC, P/N	(3) QTY RECOMMENDED
3990-01-213-1746	Binder, load: (27404) - R-45	4 - 26,000 lb (11,794 kg), type IV
5340-01-346-4612	Padlock, w/chain keyed: (81346) - ASTM F883	2
2510-01-060-7116	Plate, cover, intermediate: (59306) - FB7556	6 - 7 x 8 ft (2.13 x 2.44 m), for carrying ammunition
5340-01-317-2657	Strap, elastic: (1F926) - 6	1 each - clip end, as required
5340-01-029-9085	Strap, rubber, tiedown: (13435) - 13034	1 each - 2/S-hooks, as required
2540-01-138-3995	Tarpaulin, bow: (19207) - 12255591	9
2540-00-797-9195	Tarpaulin, forest green: (19207) - 12255592	1 - 47 x 14.5 ft (14.33 x 4.42 m)
2540-01-333-2543	Tarpaulin, tan: (19207) - 12255592-1	1 - 47 x 14.5 ft (14.33 x 4.42 m)
5340-00-980-9277	Tiedown assembly, non-nuclear: (19207) - 10900880	25 - max/trailer (web)
1670-00-725-1437	Tiedown assembly, non-nuclear: (81349) - MIL-T-27260 Type CGU1B	25 - max/trailer (web)
5340-01-204-3009	Tiedown assembly, nuclear: (19200) - MIL-PRF-71224	25 - max/trailer (web)

Table 1. Additional Authorization List (AAL) for the M871R Series Trailer - Continued.

(1) NSN	(2) DESCRIPTION, CAGEC, P/N	(3) QTY RECOMMENDED
8340-01-009-6285	Tarp, weather resistant, 6 ft x 6 ft, tan	Quantity as required
8340-00-841-6453	Tarp, weather resistant, 5 ft x 5 ft, olive drab	Quantity as required
8340-00-841-6454	Tarp, weather resistant, 6 ft x 10 ft, olive drab	Quantity as required
3940-01-449-2369	Net, draft cover, 6 1/2 ft x 12 ft	Quantity as required
3940-01-449-2385	Net, draft cover, 8 ft x 14 ft	Quantity as required
3990-01-213-1746	Loadbinder, 26,000 lb, type IV	Quantity as required
4010-00-449-6573	Chain: 3/4 in. x 12 ft, WLL: 168,000 lb	Quantity as required
4010-00-803-8858	Chain: 1/2 in. x 12 ft, WLL: 8,250 lb	Quantity as required

END OF WORK PACKAGE

**FIELD AND SUSTAINMENT MAINTENANCE
EXPENDABLE AND DURABLE ITEMS LIST**

SCOPE

Table 1 lists expendable and durable items referenced in this manual. Table 2 provides supplemental expendable and durable items. Tables 3 and 4 list CARC paint. These listings are for informational purposes only and are not authority to requisition the listed items. These items are authorized to you by CTA 50-970, *Expendable/Durable Items (Except Medical, Class V Repair Parts, and Heraldic Items)*, or CTA 8-100, *Army Medical Department Expendable/Durable Items*.

EXPLANATION OF COLUMNS IN TABLES 1 AND 2

1. **Column (1) - Item Number (Table 1 only)**. This number is referenced in the appropriate work package Initial Setup list or in the narrative instructions to identify the item; e.g., Use Antiseize compound (Item 1, WP 0085).
2. **Column (2) - Level**. This column identifies the lowest level of maintenance that requires the listed item.
 - C - Operator/Crew
 - O - Organizational
3. **Column (3) - National Stock Number**. This is the National Stock Number assigned to the item, which you can use to requisition it.
4. **Column (4) - Description, CAGEC, and Part Number**. This provides the other information you need to identify the item.
5. **Column (5) - Unit of Issue (U/I)**. This column shows the physical measurement or count of an item, such as gallon, dozen, gross, etc.

Table 1. Expendable and Durable Items for the M871R Series Trailer.

(1) ITEM NUMBER	(2) LEVEL	(3) NATIONAL STOCK NUMBER	(4) DESCRIPTION, CAGEC, AND PART NUMBER	(5) U/I
1	O	8030-00-753-4953	Antiseize compound (81349) MIL-A-13881 1 Pound Can	LB
2	C	7920-00-061-0038	Brush, scrub (83421) 7920-00-061-0038	EA
3	C	6850-01-474-2318 6850-01-474-2320 6850-01-474-2321	Cleaning compound, solvent, type III (81349) MIL-PRF-680 1 Gallon Can 5 Gallon Can 55 Gallon Drum	GL BX DR
4	O	5350-00-192-5047 5350-00-192-5049 5350-00-192-5051	Cloth, abrasive (58536) A-A-1048 80 grit - 50 sheets 120 grit - 50 sheets 180 grit - 50 sheets	PG PG PG
5	C	7930-00-282-9699	Detergent, general purpose, liquid (83421) 7930-00-282-9699 1 Gallon Can	GL
6	C	9150-01-197-7688 9150-01-197-7693 9150-01-197-7690 9150-01-197-7692	Grease, automotive and artillery (GAA) (81349) M-10924-A 2-1/4 Ounce Tube (81349) M-10924-B 14 Ounce Cartridge (81349) M-10924-C 1-3/4 Pound Can (81349) M-10924-E 35 Pound Can	TU CA CN CN
7	O	9150-00-040-3891	Grease, dielectric (silicone) (08125) G305	EA
8	O	5970-00-476-6717	Insulating varnish, electrical (75037) 1602 13 Ounce Aerosol Can	CN
9	O		Linseed oil (96162) Boiled Linseed Oil	

Table 1. Expendable and Durable Items for the M871R Series Trailer - Continued.

(1) ITEM NUMBER	(2) LEVEL	(3) NATIONAL STOCK NUMBER	(4) DESCRIPTION, CAGEC, AND PART NUMBER	(5) U/I
10	C	8010-00-152-3245 8010-00-684-8789	1 Gallon Can 5 Gallon Can Oil, lubricating OEA, arctic (81349) MIL-L-46167	GL CN
11	C	9150-00-402-4478 9150-00-402-2372 9150-00-491-7197	1 Quart Can 5 Gallon Can 55 Gallon Drum Oil, lubricating OE/HDO-10 (81349) MIL-PRF-2104	QT CN DR
12	C	9150-00-189-6727 9150-00-186-6668 9150-00-191-2772	1 Quart Can 5 Gallon Can 55 Gallon Drum Oil, lubricating OE/HDO-30 (81349) MIL-PRF-2104	QT CN DR
13	C	9150-00-186-6681 9150-00-188-9858	1 Quart Can 5 Gallon Can	QT CN
14	O	7290-00-205-1711	Rag, wiping (80244) 7920-00-205-1711 50 Pound Bale	BE
15	O	8030-01-414-8947	Rust inhibitor (03GK3) T32P5 5 Gallon Can	CN
16	O	8030-00-252-3391	Sealing compound (80064) 1756371 11 Ounce Tube	TU
16	O	9905-00-537-8954	Tag, marker (64067) 9905-00-537-8954 Bundle of 50	BD

Table 1. Expendable and Durable Items for the M871R Series Trailer - Continued.

(1) ITEM NUMBER	(2) LEVEL	(3) NATIONAL STOCK NUMBER	(4) DESCRIPTION, CAGEC, AND PART NUMBER	(5) U/I
17	O	5975-00-903-2284	Tiedown strap Electrical components 4 in. Length, Black, Package of 100 (96906) MS3367-4-0	HD
		5975-00-984-6582	6 in. Length, Black, Package of 100 (96906) MS3367-1-0	HD
		5975-00-935-5946	13.35 in. Minimum Length, Brown (96906) MS3367-2-1	EA
18	O		UV wood protector Requires 4 Gallons per Deck	GL

Table 2. Supplemental Expendable and Durable Items List for the M871R Series Trailer.

(1) LEVEL	(2) NATIONAL STOCK NUMBER	(3) DESCRIPTION, CAGEC, AND PART NUMBER	(4) U/I
O	5350-00-221-0872	Cloth, abrasive, crocus, 50 sheets (81348) P-C-458	EA
O	7920-01-004-7847	Cloth, lint free Rymple cloth 301 purified	EA
O	8540-00-262-7177	Hand cleaner, container (09177) 200-767-4A	EA
O	8040-01-152-8105	Epoxy adhesive	KT
O	8040-00-152-0063	Vinyl adhesive	BT
O	5970-00-184-2002	Dielectric tape, electrical	RD
O	8030-01-159-4844	Sealant, silicone, RTV: 8-1/2-oz (241-g) tube (11862) 1052734	OZ
O	5970-00-644-3167	Tape, insulation, electrical: 85-ft (25.9 m) roll (81348) HH-510	FT
O	8020-00-689-5379	Paint roller kit: 9 in. (22.86 cm) w/paint tray	KT
O	8020-00-682-6498	Paint roller cover: 9 in. (22.86 cm), 1 in. (2.54 cm) pile	EA

Table 2. Supplemental Expendable and Durable Items List for the M871R Series Trailer - Continued.

(1) LEVEL	(2) NATIONAL STOCK NUMBER	(3) DESCRIPTION, CAGEC, AND PART NUMBER	(4) U/I
O	8030-01-414-7423	Carwell corrosion treatment (12) 16-oz (454 g) bottles	EA
O	8030-01-414-7430	Carwell corrosion treatment 55-gal. (208.2 L) drum	GL
O	8030-01-414-1413	Carwell corrosion treatment 55-gal. (208.2 L) drum, Includes applicator and video	GL
O	7920-00-263-0328	Wooden extension handle: 60 in. (152.4 cm), for paint roller	EA
O	8030-01-282-5626	Rubber preservative compound: (ozone protection for tires)	GL
O	5640-00-103-2254	Plastic-coated cloth tape: 2 in. (5.08 cm) wide, 60-yd (54.86 m)	RO
O	5640-00-103-2254	Tape, pressure sensitive, adhesive: 60-yd (54.86 m)	RO
O	5975-00-156-3253	Tiedown straps, nylon: 13-1/2 in. (34.29 cm)	HD
O	4730-00-289-8148	Cap, lubrication fitting, protective	EA
O	5340-00-450-5718	Caps, plugs, protective dust moisture	SE
O	8030-00-015-1295	Antiseize compound: 1-lb (0.45 kg)	CN
O	6810-00-264-6715	Molybdenum disulfide powder (graphite)	LB
O	8030-00-938-1947	Corrosion preventive compound	CN
O	9150-00-943-6880	Molybdenum disulfide grease	TU
O	8010-00-141-7838	Nonslip walkway paint Type II olive drab	GL
O	8010-00-641-0427	Nonslip walkway paint Type II black	GL
O	8040-00-455-5359	Automotive adhesive, black	TU
O	8030-00-664-4944	Canvas preservative, liquid, or brush or spray	GL
O	8340-01-423-6231	Repair tape, tarp (for small repairs on polyester or duct material) (81349) – MIL-C-44103	RO

END OF WORK PACKAGE

FIELD AND SUSTAINMENT MAINTENANCE

10/20 INSPECTION CHECKLIST

Model:	
Serial Number:	
Registration Number:	
Document Number:	
Mechanic/Inspector's Name:	
Location:	
Unit:	
Date:	
Complete checklist for semitrailer being inspected. Fill in name of mechanic/inspector. Check all appropriate areas, i.e., accept/reject/corrected. Note defects and corrections on last sheet.	

NOTE

During the walk-around inspection, examine semitrailer for general appearance including paint, workmanship type defects, and missing or damaged equipment. Paint scratches that do not penetrate top coat are acceptable.

KEY:	A = Accept	R = Reject	C = Corrected
	A	R	C
1. Front, Top, and Sides of Semitrailer:			
A. Gladhands/Hardware:			
(1) Gladhands for damage and leakage			
(2) Gladhands for unclean mounting surfaces			
(3) Fittings and packings for wear and presence			
B. Converter Box:			
(1) Damage and/or missing hardware			
(2) Pins missing or damaged			
C. Data Plates/Labels/Decals:			
(1) Presence			
(2) Damage/legibility			
D. Bulkhead:			
(1) Retaining hardware loose/missing			
(2) Damage			
1. Front, Top, and Sides of Semitrailer - Continued:			

KEY: A = Accept R = Reject C = Corrected			
	A	R	C
(3) Document box condition			
E. Kingpin/Bolster Plate:			
(1) Any damage			
(2) Weld cracks			
(3) Light coat of lubricant on kingpin and bolster plate			
F. Landing Legs/Shoes/Handcrank:			
(1) Damage and secure mounting			
(2) Smooth operation			
(3) Hardware missing			
G. Decking:			
(1) Damage			
(2) Condition			
H. Side/Rear Board Storage Rack (if required):			
(1) Damage			
(2) Missing hardware			
I. Reflectors:			
(1) Presence			
(2) Damage or missing hardware			
J. Side/Rear/Racks, Stakes, and Hardware (if required):			
(1) Damage or missing hardware			
(2) Apparent misalignment			
K. Spare Tire Carrier/Hardware:			
(1) Presence			
(2) Damage or missing hardware			
L. BII:			
(1) Presence			
(2) Condition/Secured			
M. Groundboards/Chocks and Hardware:			
(1) Presence			
(2) Condition			
N. Twist Locks and Tiedowns:			
(1) Damage			
1. Front, Top, and Sides of Semitrailer - Continued:			

KEY:			
A = Accept	R = Reject	C = Corrected	
	A	R	C
(2) Condition			
2. Lighting, Warning, and Safety:			
(1) Damage or missing hardware			
(2) Corroded connectors			
(3) Operation			
3. Main Electrical Harness:			
(1) Damage or missing hardware			
(2) Corroded connectors			
4. ABS Sensor Cables, ECU, Modules, Diagnostic Adapter, and Cables			
(1) Damage or missing hardware or cables			
(2) Blink code adapter cable and cap damaged or missing			
(3) Corroded connectors			
(4) Operation			
5. Hoses, Lines and Fittings:			
(1) Missing or damaged			
(2) Loose or twisted			
(3) Evidence of leakage			
6. Stowage Box:			
Damage or missing hardware/seal			
7. HUBODOMETER®:			
(1) Presence			
(2) Damage and missing hardware			
8. Hubcaps:			
Damage or missing hardware			
9. Air Reservoirs, Air Brake Chamber, and ASAs:			
(1) Presence			
(2) Damage or missing/loose hardware			
(3) Operation			
(4) Moisture drained from air tanks			
10. Suspension and Hardware, Correct Torques:			

KEY: A = Accept R = Reject C = Corrected			
	A	R	C
(1) Damage or loose/missing hardware			
(2) Nuts torqued to specification			
11. Tires, Wheels, and Caps:			
(1) Damaged valves or missing caps			
(2) All tires for damage and unusual tread wear			
(3) Proper inflation, including spare			
(4) Wheels for damage and rust			
(5) Presence, torque, and condition of all mounting hardware			
12. Overall Condition:			
(1) Paint			
(2) Lubrication, oil can points			
(3) Corrosion protection			
(4) Clean and mission ready			

**10/20 Inspection Summary Sheet Deficiency
(Brief Description/Corrective Action)**

1	
2	
3	
4	
5	
6	
7	
8	
9	
10	
11	
12	
13	
14	
15	
16	

END OF WORK PACKAGE

FIELD AND SUSTAINMENT MAINTENANCE
CONVERTING FRACTIONS TO DECIMALS AND METRIC EQUIVALENTS

FRACTIONS (inches) TO DECIMALS (inches) and METRIC EQUIVALENTS

FRACTION (inches)	DECIMAL (inches)	MM	FRACTION (inches)	DECIMAL (inches)	MM	FRACTION (inches)	DECIMAL (inches)	MM	FRACTION (inches)	DECIMAL (inches)	MM
1/64	.016	.397	17/64	.266	6.747	33/64	.516	13.097	49/64	.766	19.447
1/32	.031	.794	9/32	.281	7.144	17/32	.531	13.494	25/32	.781	19.844
3/64	.047	1.191	19/64	.297	7.541	35/64	.547	13.891	51/64	.797	20.241
1/16	.063	1.588	5/16	.313	7.938	9/16	.563	14.288	13/16	.813	20.638
5/64	.078	1.984	21/64	.328	8.334	37/64	.578	14.684	53/64	.828	21.034
3/32	.094	2.381	11/32	.344	8.731	19/32	.594	15.081	27/32	.844	21.431
7/64	.109	2.778	23/64	.359	9.128	39/64	.609	15.478	55/64	.859	21.828
1/8	.125	3.175	3/8	.375	9.525	5/8	.625	15.875	7/8	.875	22.225
9/64	.141	3.572	25/64	.391	9.922	41/64	.641	16.272	57/64	.891	22.622
5/32	.156	3.969	13/32	.406	10.319	21/32	.656	16.669	29/32	.906	23.019
11/64	.172	4.366	27/64	.422	10.716	43/64	.672	17.066	59/64	.922	23.416
3/16	.188	4.763	7/16	.438	11.113	11/16	.688	17.463	15/16	.938	23.813
13/64	.203	5.159	29/64	.453	11.509	45/64	.703	17.859	61/64	.953	24.209
7/32	.219	5.556	15/32	.469	11.906	23/32	.719	18.256	31/32	.959	24.606
15/64	.234	5.953	31/64	.484	12.303	47/64	.734	18.653	63/64	.934	25.003
1/4	.250	6.350	1/2	.500	12.700	3/4	.750	19.050	1	1.000	25.400

447-0217

END OF WORK PACKAGE

FIELD AND SUSTAINMENT MAINTENANCE
FASTENER SIZE AND THREAD PATTERN

FASTENER SIZE AND THREAD PATTERN

Threaded fasteners are categorized according to diameter of the fastener shank. Thread styles are divided into broad groups, the two most common being coarse (Unified Course-UNC) and fine (Unified Fine-UNF). These groups are defined by the number of threads per inch in the bolt shanks. In addition, threads are categorized by thread class, which is a measure of the degree between threads of the bolt or screws (external threads) and threads of attaching nut or tapped hole (internal threads of attaching nut or tapped hole) (internal threads). The most common thread class for bolts and screws is Class 2.

THREAD CLASSES AND DESCRIPTION		
1A	1B	Loose Fit
2A	2B	Medium Fit
3A	3B	Close Fit

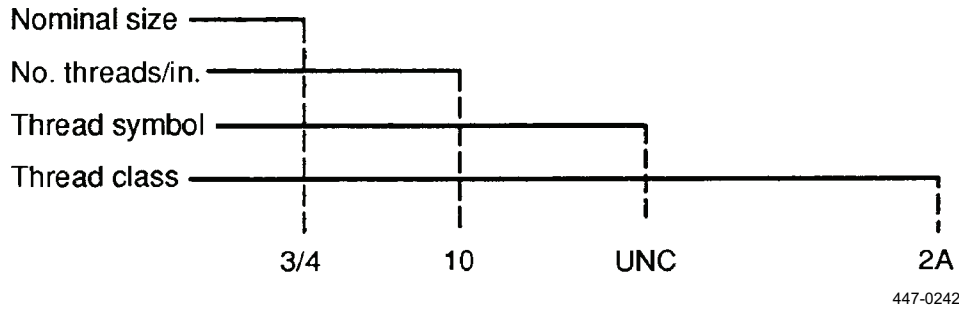
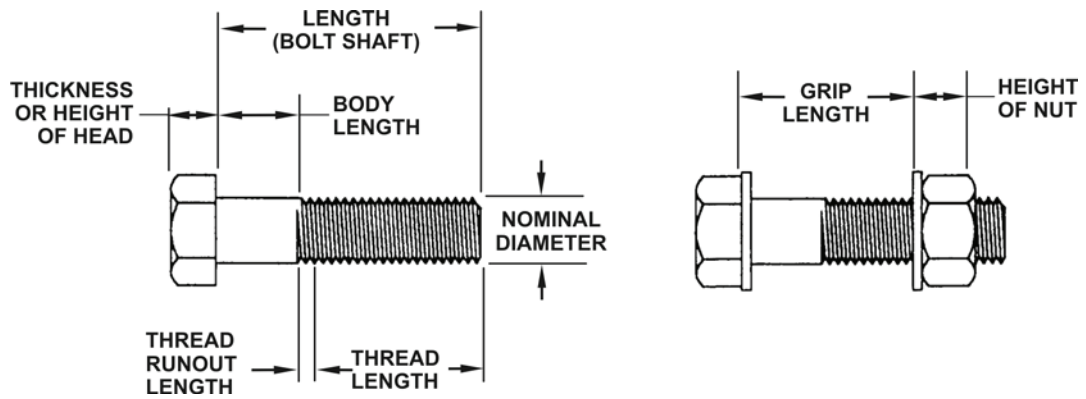

Figure 1. Fastener Size.

FASTENER SIZE AND THREAD PATTERN - CONTINUED

NOTE

Unless followed with "LH" (e.g., 3/4-10 UNC-2A-LH), threads are right-hand.



447-0243

Figure 2. Thread Pattern.

END OF WORK PACKAGE

FIELD AND SUSTAINMENT MAINTENANCE
RECEPTACLE CONVERTER BOX MAINTENANCE

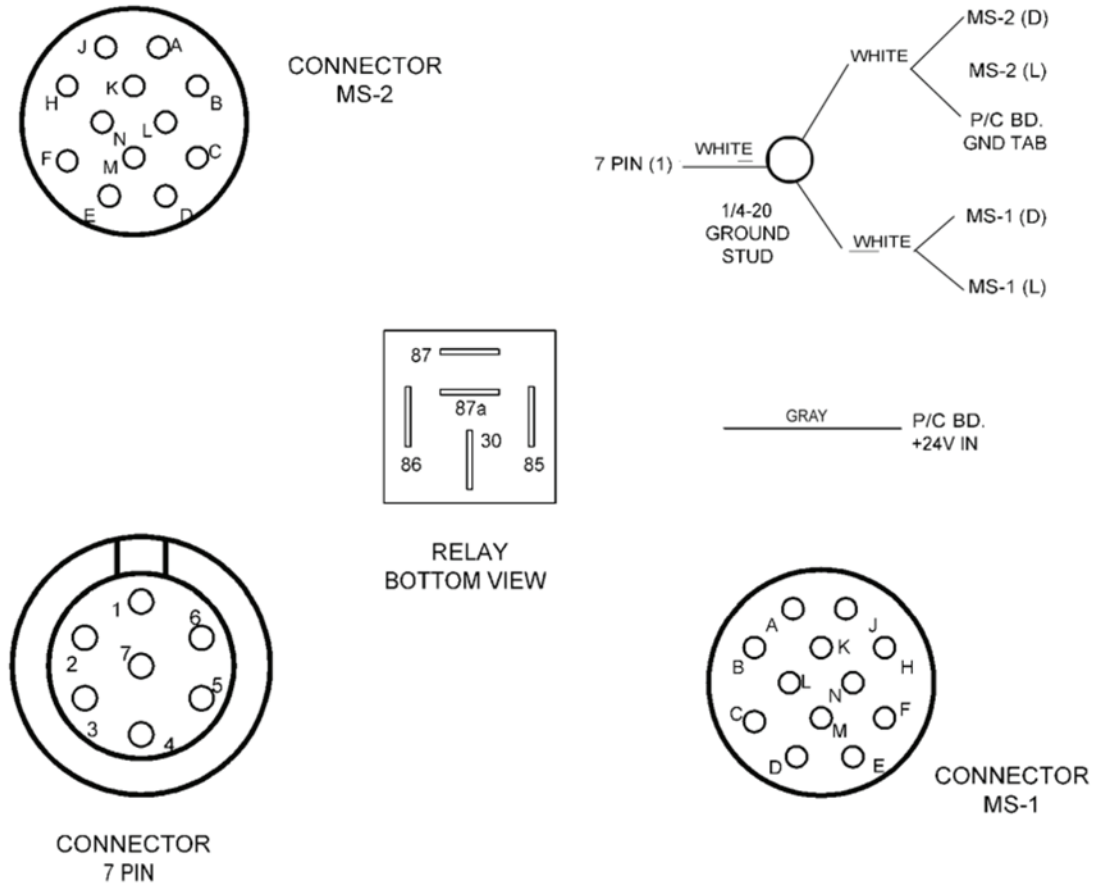

- | | | |
|------------------------------|---|----------------------------------|
| BLACK 7 PIN (2) | ⊕ | BLACK RELAY #87 & # 85 |
| BLACK / WHITE MS-1 (E) | ⊕ | BLACK / WHT MS-2 (E) & RELAY #30 |
| RED 7 PIN (4) | ⊕ | RED MS-2 (M) |
| GREEN / WHITE MS-1 (C) | ⊕ | GREEN / WHITE MS-2 (C) |
| BROWN 7 PIN (6) & RELAY #87a | ⊕ | BROWN MS-2 (N) |
| YELLOW MS-1 (B) & 7 PIN (3) | ⊕ | YELLOW MS-2 (B) |
| GREEN MS-1 (J) & 7 PIN (5) | ⊕ | GREEN MS-2 (J) |
| BLUE 7 PIN (7) | ⊕ | BLUE MS-2 (K) & P/C BD. +12V OUT |
| BLACK MS-1 (A) | ⊕ | BLACK MS-2 (A) |
| WHITE / RED MS-1 (F) | ⊕ | WHITE / RED MS-2 (F) |

447-0088

Figure 2. 0T40-0989-00 Internal Wiring Description.

Problem	Action
<p>ABS Fault w/ 24V Tow Vehicle</p>	<p>Do not remove the UTM-2412 from the trailer for these tests unless instructed. With tractor connected to military connector of trailer, tractor power on, and service brake applied:</p> <p>Check converter regulation by measuring the voltage across pin 7 (12V converter output for ABS) and pin 1 (ground) of the J560 commercial connector. The J560 connector is used as a convenient measurement point when the 24-pin military harness is applied. The reading from pin 7 to pin 1 of the J560 should be ~12V. If 12V is measured, then the converter is working properly.</p> <p>Now check from pin 1 to the trailer chassis ground (not the converter box itself). If the voltage is >1V then there is not a good ground between the converter box and the ABS chassis ground. Remove the UTM-2412, clean the ground straps and the chassis connection points. Reassemble and retest.</p> <p>If no voltage or low voltage is measured across pins 1 and 7 of the J560 connector, check the following:</p> <ol style="list-style-type: none"> 1. There is 24V supply from the tow vehicle on pin K of the military connector. 2. That there is not a short on the ABS power circuit of the trailer harness. <p>If there is a good 24V supply into the converter and the ABS power circuit is not shorted then the converter board should be replaced.</p> <p>If 24V is measured across pins 1 and 7 of the J560 connector, check the converter to trailer chassis ground as described above. If the ground is good and 24V is still present on the ABS power then the converter board should be replaced.</p>
<p>ABS Fault w/ 12V Tow Vehicle</p>	<p>This is a pass-through circuit in the UTM-2412 for the J560 ABS power. The ABS controller will see the voltage from the 12V tow vehicle as applied to pin 7 of the J560 connector. Continuity through the UTM-2412 may be confirmed by measuring from pin 7 to pin K of the 24-pin connector on the trailer harness side. If continuity does not exist, check for corrosion on the connector terminals. If still no continuity, there is a bad internal connection and the UTM-2412 must be serviced.</p>
<p>No Clearance, Side Marker or ID Lights</p>	<p>These are pass-through circuits within the UTM-2412. Check that lamp(s) are functional before troubleshooting wiring or converter box.</p> <p>Check that voltage is available on the appropriate wires from the tow vehicle.</p> <p>Check that the trailer has a solid ground with the tow vehicle.</p> <p>Check continuity of the pass-through circuits in the UTM-2412 per the diagram shown in Figure 1 of this work package.</p> <p>Check for corrosion or oxidation of connector pins on the module and the connecting harnesses (tow vehicle and trailer).</p> <p>If 24V is on tow vehicle harness Pin-E but is not measured on trailer harness Pin-N then the UTM-2412 internal relay is bad and should be replaced.</p>
<p>Trailer Lights are Dim</p>	<p>Service lamps must be capable of 12-24V operation. If a 24V lamp is used it will be very dim on a 12V tow vehicle.</p> <p>Check for corrosion on connector pins and clean if necessary.</p> <p>Check that there is a solid ground connection between the trailer and the tow vehicle.</p>

447-0000

Figure 3. Troubleshooting.

END OF WORK PACKAGE

FIELD AND SUSTAINMENT MAINTENANCE

KINGPIN MAINTENANCE AND REPLACEMENT RECOMMENDATIONS

KINGPIN MAINTENANCE

Inspection and maintenance of the trailer upper coupler and kingpin is just as important as the inspection and maintenance of its mating component, the fifth wheel. The following procedures are based upon recommendations outlined in SAE J2228. They should be completed every 3 months, or 30,000 miles, to ensure proper and safe kingpin/fifth wheel coupling.

1. **Upper Coupler Plate Flatness.** Using a 48 in. (122 cm) straightedge, check the flatness in all directions. Any bumps, valleys or warping will cause uneven loading of the fifth wheel, which could result in damage to the top plate and poor lock life. Replace the trailer upper coupler plate if flatness exceeds the specifications shown in Figure 1.
2. **Inspect the Kingpin for Straightness.** Using a square or Holland Kingpin Gage (TF-0110), check to see if the kingpin is bent. A bent kingpin accelerates lock wear and may interfere with proper fifth wheel locking. This also may indicate damage. The kingpin should be replaced if it exceeds 1 degree from square in any direction (see Figure 1).

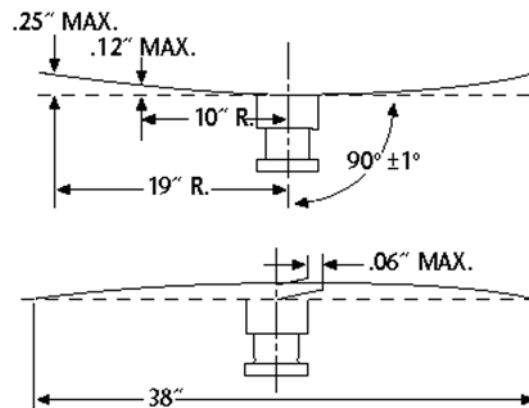

447-0089

Figure 1. Straightness.

KINGPIN MAINTENANCE - CONTINUED**CAUTION**

If a lube plate is used in your operation, make sure to check the kingpin length. The kingpin must be sized to compensate for the thickness of the lube plate. Otherwise, the kingpin will be too short. If the kingpin length is improper, the king pin should be replaced. For more information, see *Holland Service Bulletin XL-SB4*.

3. **Inspect the Kingpin for Proper Length.** Using a Holland Kingpin Gauge, check the length as shown in Figure 2.



447-0090

Figure 2. Proper Length.

4. **Inspect the Kingpin for Wear.** Using a Holland Kingpin Gauge, check the wear on both the 2 in. and 2.88 in. (5.1 cm and 7.3 cm) diameters. Wear of 0.13 in. (3.3 mm) is indicated if the appropriate diameter enters the gage slot. Replace the kingpin if the gage slides into the appropriate gage slot (see Figure 3).



447-0091

Figure 3. Wear.

5. **Check the Kingpin Mounting.** In addition to being a safety hazard, a loose mounting will cause excessive chucking and rapid lock wear. Reinstall or replace any kingpin which is not securely mounted.
6. **Check the Kingpin for Damage.** Inspect the kingpin for any nicks, gouges, deformation or cracks which may interfere or affect the safe use of the kingpin. Replace the kingpin if any damage is noted.

KINGPIN WELD REPAIRS PROHIBITED**WARNING**

When welding, use a procedure which assures a sound, good quality weld which protects the welding operator and others. Overwelding may cause distortion and damage and underwelding may not develop sufficient strength. A low hydrogen process and AWS 370XX filler metal are recommended. Take precautions to ensure that the vehicle electrical system is not damaged by the welding.

Kingpins are made from quenched and tempered alloy steel. Weld repairs of any type will affect the strength and wear resistance of the kingpin. Additionally, arc strikes or weld craters could develop a stress riser, leading to a fatigue failure. For these reasons, Holland warns against any weld repairs. If any deficiencies are noted during kingpin inspection, the kingpin should be replaced (see Figure 4).

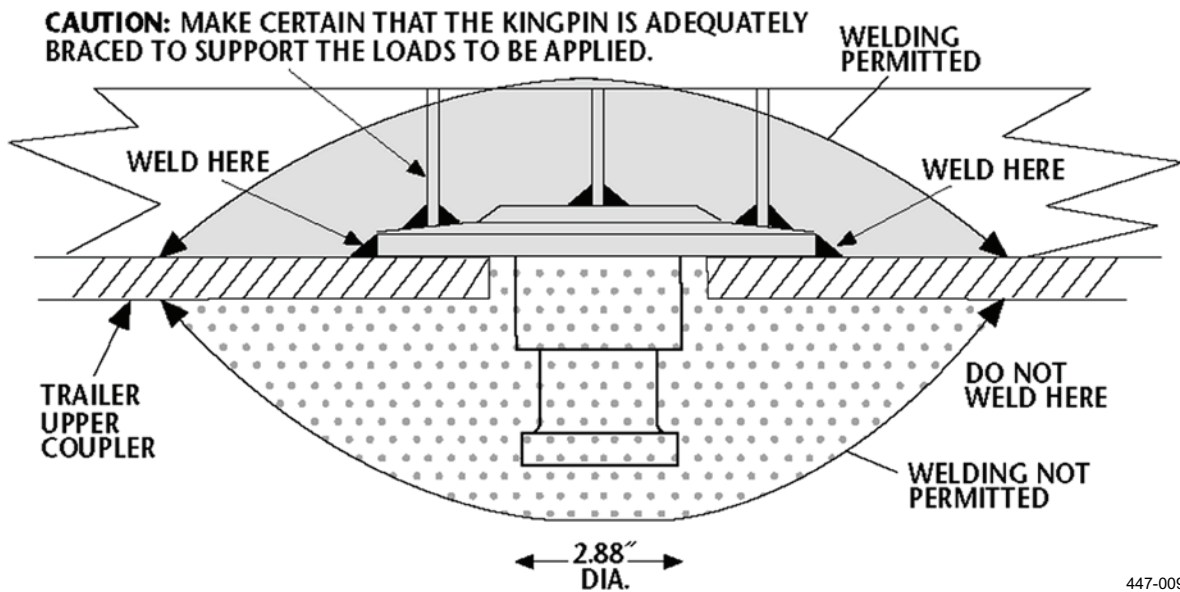

447-0092

Figure 4. Deficiencies.

KINGPIN REPLACEMENT RECOMMENDATIONS

1. A kingpin should be selected which is similar to the type removed or, if of a different style, one which can be adequately braced. The kingpin must also be matched to the thickness of the upper coupler to maintain the SAE dimensions. Kingpins are manufactured in different lengths to match the thickness of the upper coupler. Improper selection will result in a kingpin that is too long or too short (see Figure 5).

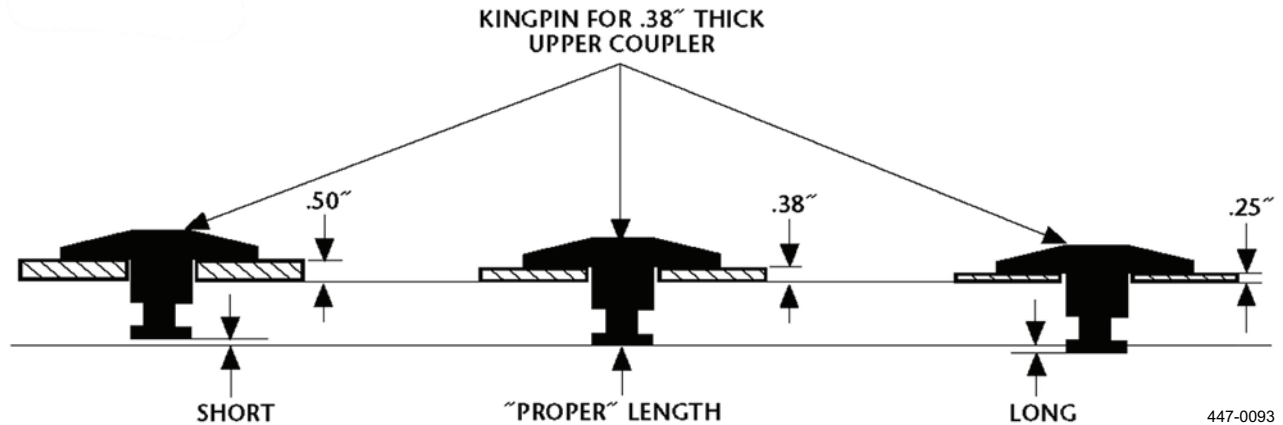

Figure 5. Replacement.

2. **Installation Procedure Recommendations.** Because of its important role, the kingpin must be properly installed. Proper installation includes an adequate upper coupler design, with bracing, which meets the requirements of SAE J133 and welding personnel who are properly trained and certified. To determine the specific material used in your kingpin, refer to the proper kingpin literature. The kingpin must not be welded to the upper coupler at the 2.88 in. (7.3 cm) diameter interface (see Figure 4). Finally, the installer should take adequate precautions to protect the trailer, himself, and others during the installation process (see Holland Service Bulletin XL-SB14 for additional welding procedures on motor vehicles).

END OF WORK PACKAGE

FIELD AND SUSTAINMENT MAINTENANCE
FIFTH WHEEL AND UPPER COUPLER CONNECTIONS

GENERAL

Fifth wheels and upper couplers are a system that work together and both must be designed to ensure an even distribution of the trailer's vertical load between the two surfaces. Upper coupler designs utilizing thinner, high-strength materials in combination with smaller and more widely spaced support structures may increase upper coupler deflection. Increased deflections in the upper coupler (see Figures 3, 4, and 5) can lead to fifth wheel center loading, premature upper coupler wear, and difficult release handle operation.

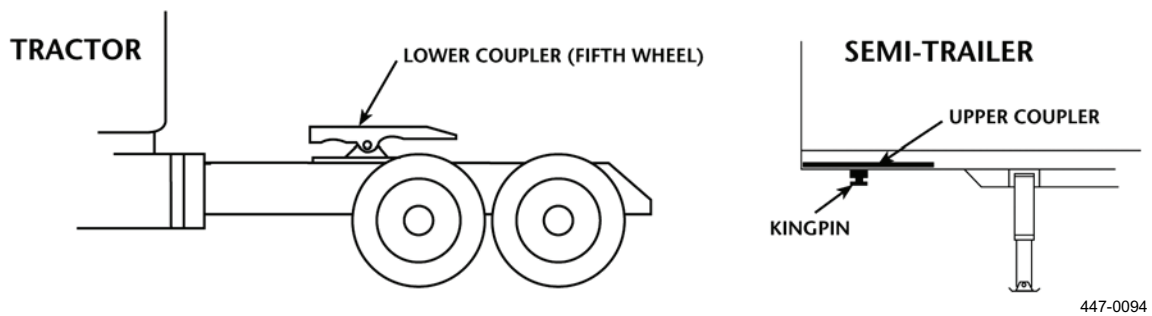
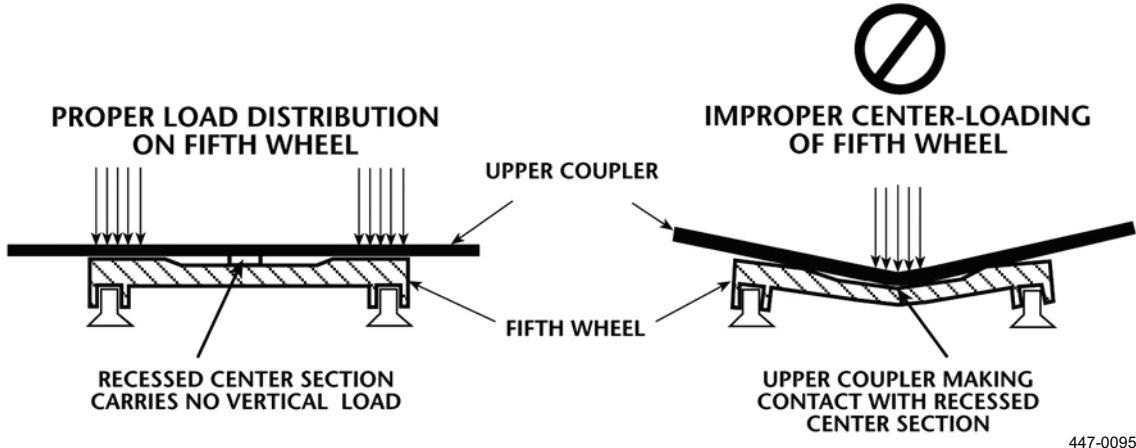

Figure 1. Fifth Wheel and Upper Coupler.

CENTER LOADING

1. A Holland fifth wheel is designed to carry its load over the machined surfaces of the fifth wheel top plate. The center section of the fifth wheel is purposely recessed to prevent it from carrying any vertical load (see Figure 2). A “bowed” upper coupler can cause the vertical load to be concentrated in the center of the fifth wheel (see Figure 3). “Center loading” causes the fifth wheel to act like a beam, flexing up and down over every bump and ripple in the road. This continuous flexing can lead to top plate cracking.
2. **Identification.** Center loading can often be identified by shiny spots in the recessed area of the top plate and in the mating area on the upper coupler. Additionally, a straightedge placed across the fifth wheel or upper coupler may reveal inadequate contact area due to the deflections on the mating surfaces.



447-0095

Figure 2. Proper Load Distribution and Center Loading.

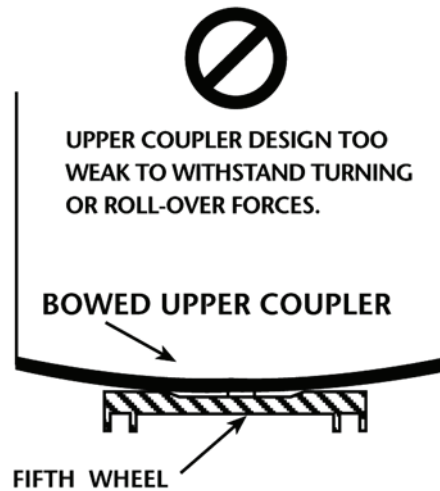

447-0096

Figure 3. Bowed Upper Coupler.

PREMATURE WEAR/UPPER COUPLER FAILURE

1. A wavy upper coupler or severely distorted fifth wheel can result in inadequate surface contact (see Figure 4). Inadequate contact dramatically increases surface pressures, pushing (scraping) grease out of the way and leading to bare steel-on-steel contact. This will cause galling, premature wear, and potential failure as the fifth wheel will begin to wear through the upper coupler.
2. **Identification.** Severe wear areas, galling, and/or dry spots in either the upper coupler or fifth wheel.

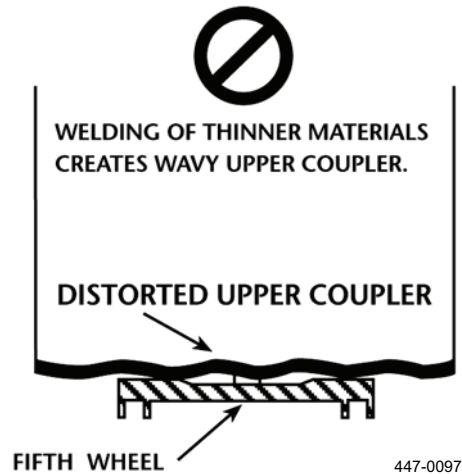

Figure 4. Distorted Upper Coupler.

DIFFICULT RELEASE HANDLE OPERATION

1. Heavy loading and inadequate upper coupler strength can cause the upper coupler to “bow,” pulling the kingpin upward when the trailer weight is resting on the fifth wheel (see Figure 5). The release handle will be difficult to pull because the kingpin is pulling up on the fifth wheel locks.
2. **Identification.** The release handle is easy to pull when weight is removed from the fifth wheel top plate, but difficult to pull when there is a load on the upper coupler and fifth wheel. This condition may not be detected by using a straightedge because the upper coupler may be straight when unloaded, but deflect severely under load.

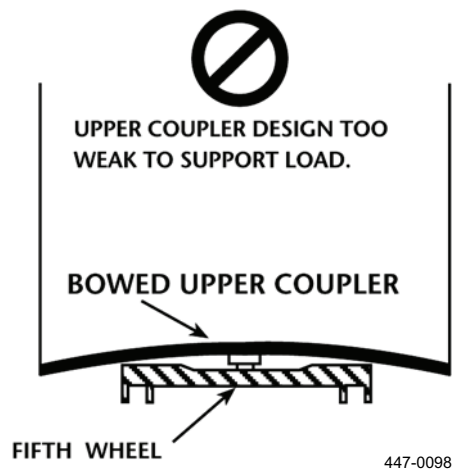

Figure 5. Bowed Upper Coupler.

PREVENTIVE MEASURES

These conditions can be eliminated by taking the following preventive measures:

1. Specify trailer upper couplers and bracing which are appropriate for the trailer application. Please note that the allowable limits for upper coupler plate bowing provided in SAE recommended practice J700b are maximum allowable deflections on worn, in-service units before repairs are required. New upper couplers should be designed to withstand normal loading with minimal deflection and should NOT be designed to deflect to the SAE limits. (Refer to Holland Service Bulletin XL-SB20 for additional information on upper coupler specifications.)
2. Use fifth wheel greases with EP (extreme pressure) characteristics.
3. Conduct regular inspections and repairs of upper couplers and fifth wheels which exhibit any of these problems. A good guideline for these inspections can be found in the Holland publication *How to Get the Most From Your Holland Fifth Wheel*, and is available from any Holland warehouse distributor.

END OF WORK PACKAGE

FIELD AND SUSTAINMENT MAINTENANCE
 COUPLING INSTRUCTIONS

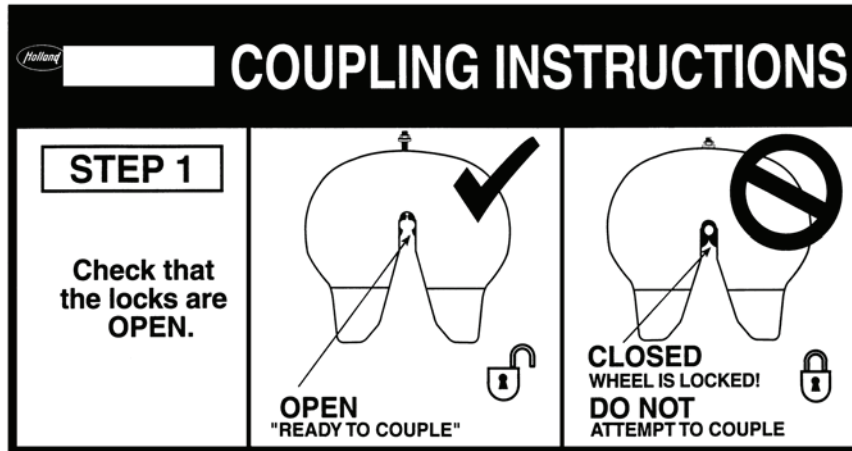

447-0099

Figure 1. Coupling.

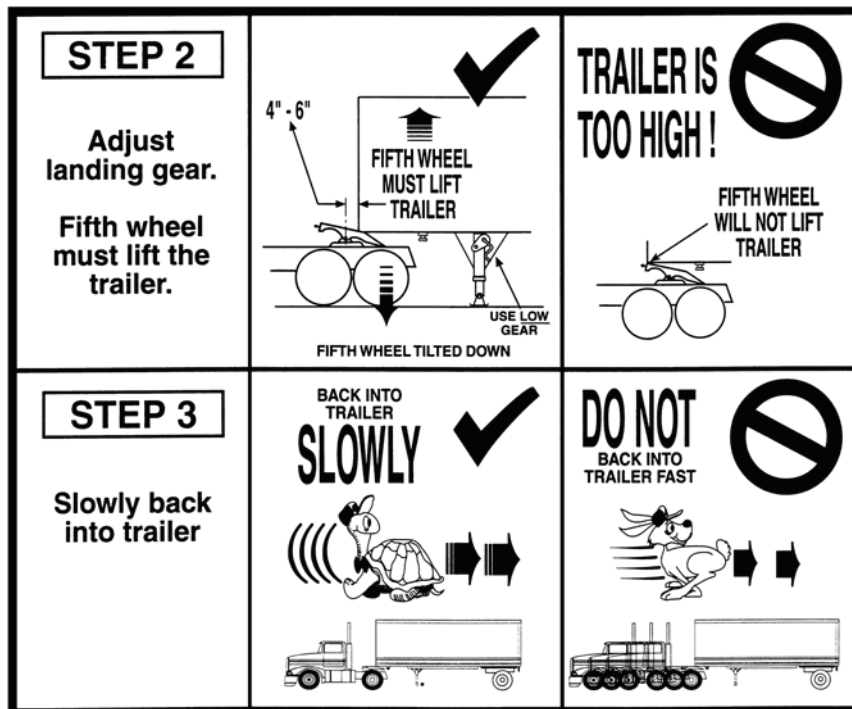

447-0100

Figure 2. Coupling.

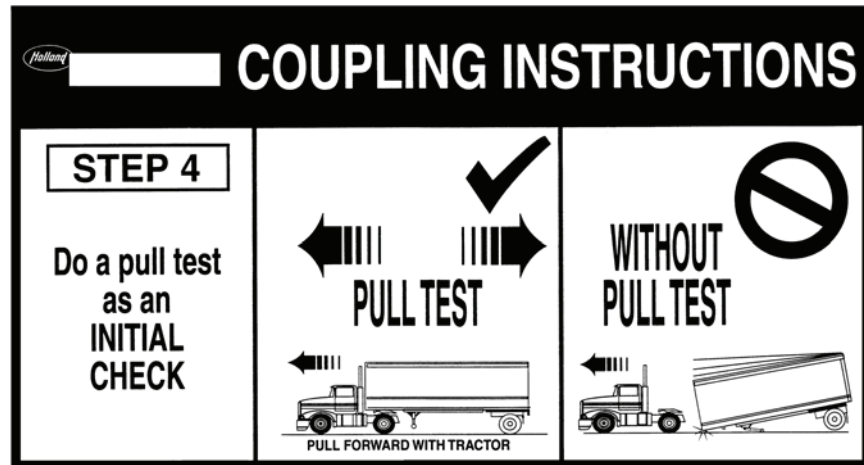

Figure 3. Coupling.

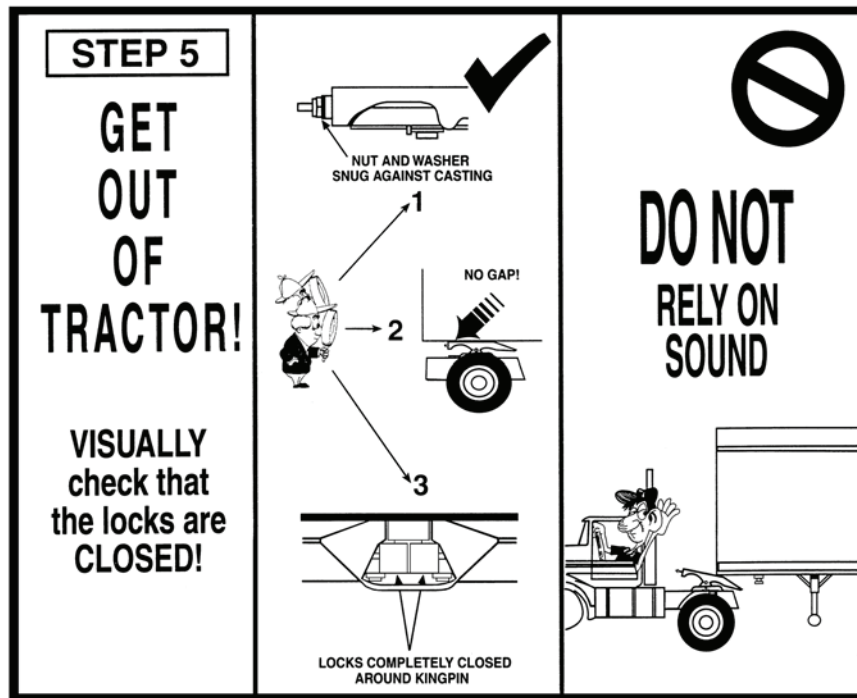

Figure 4. Coupling.

END OF WORK PACKAGE

FIELD AND SUSTAINMENT MAINTENANCE
TECHNICAL INFORMATION FOR LED AND FILAMENT BULB LIGHTING
General, Tips to Prolong Lighting Life

GENERAL

1. Cleaning lenses and housings that are polycarbonate with solvents will result in the softening, crazing, and/or cracking of the plastic. This is especially true of polycarbonate lamps and mounting bases, which may be under stress in their normal applications. The following cleaners are compatible with polycarbonate (not a complete list):
 - a. Mild soap and water
 - b. Mineral spirits
 - c. #1 and #3 denatured alcohol
 - d. White kerosene
 - e. Methyl, isopropyl, and isobutyl alcohols
 - f. Polycarbonate cleaners
2. The following must NOT be used to clean polycarbonate (not a complete list):
 - a. Acetone
 - b. Gasoline
 - c. Carbon tetrachloride
 - d. Liquid detergents
 - e. Stanisol naphtha
 - f. Oils
3. All lamps will last longer if they run cool. Dirt on the lens increases the heat, so keep them as clean as possible. Other people must see your semitrailer and that is one of the purposes of the lighting system: to be seen.

TIPS TO PROLONG LIGHTING LIFE**WARNING**

Certain lighting products generate heat. Care should be taken to avoid contact with flammable materials. The unit can generate enough heat to cause injury to personnel or damage to the equipment.

1. Never use a test probe to pierce wire insulation when troubleshooting lighting problems. Wicking action takes place which causes moisture to travel along the wire strands and corrode critical connections. If probing harness or wire is necessary, make sure the puncture is completely sealed.
2. To correct voltage problems, discover the real cause. Under-voltage is often caused by poor connections. To correct under-voltage, do not just increase the voltage; find out what caused the under-voltage.
3. Many discarded lamps are still in good condition.

TIPS TO PROLONG LIGHTING LIFE - CONTINUED**NOTE**

Test all lamps one more time before you discard them. Up to 20 percent of lamps discarded are still in good operating condition.

4. Open the lens on a discarded lamp and examine the bulb.
 - a. A bulb with stretched or broken filaments was subject to vibration.
 - b. A yellowish, whitish, or bluish glaze on the bulb indicates a rupture in the bulb glass envelope, and a possible leak.
 - c. A dark metallic finish indicates old age.
 - d. A black, sooty bulb indicates a poor seal in the bulb.
5. Lubricate sockets, pigtails, battery terminals, and connections with non-conductive anti-corrosion compound to protect against corrosion and water.
6. Look for loose, bare, or unsupported wiring and fixtures. Harnesses and wiring should be on the underside of the top frame members rather than on the bottom where dirt and road splash collect.
7. You should never crank a truck when any lights or accessories are on. Also, never leave markers and hazard lights on when parked against a dock. Melted lenses are a sure sign that the vehicle has been parked against a dock while the lights were on.
8. Inspect the grommets that house the lamps. As they age, they eventually will deteriorate from sunlight, ozone, and harmful chemicals. New grommets restore shock protection, security, and improve appearance.

END OF WORK PACKAGE

FIELD AND SUSTAINMENT MAINTENANCE**LANDING GEAR OPERATING, MAINTENANCE, AND REPAIR PROCEDURES**
Operation of Holland Formula 150 Landing Gear, Remove Tractor from Semitrailer,
Connect Tractor to Semitrailer, Lubrication,
Troubleshooting, Alignment

NOTE

Do not deviate from these instructions. Any changes or deviations will void all warranties, expressed or implied, unless written consent is first obtained from the factory.

OPERATION OF HOLLAND FORMULA 150 LANDING GEAR**WARNING**

Ensure the landing leg scissor assembly retaining (locking) pins do not present a contact hazard to personnel. The pins can extend outward and cause injury to personnel.

CAUTION

- Always grip crank handle securely with both hands before shifting.
- Never shift landing gear under load.
- Never leave the crank unsecured.
- Never raise or lower a loaded trailer in high gear.
- Failure to comply could cause damage to equipment.

NOTE

Holland Formula 150 2-speed gearbox has high- and low-range gears. High-range gear is to be used only for rapid traverse up from and down to the ground and is not intended to lift or lower any load. For additional information, see Holland publication XL-FW302-XX, *Fifth Wheel Operating Instructions*.

Extend

On outside-mounted landing gear, engage the crank with the crankshaft and turn the crank clockwise. Inside-mounted landing gear are extended by turning the crank counterclockwise. Using high gear, lower the landing gear until the pads make contact with the ground. To reduce the load on the fifth wheel, shift to low gear and crank an additional four to eight turns. Leave the landing gear in low gear and store the crank handle in the holder provided.

OPERATION OF HOLLAND FORMULA 150 LANDING GEAR - CONTINUED**Retract**

1. On outside-mounted landing gear, engage crank with crankshaft and turn the crank counterclockwise. Inside-mounted landing gear are retracted by turning the crank clockwise. Retract the landing gear using low gear until unloaded. Then shift to high gear and continue cranking until fully retracted. Leave the crankshaft engaged to prevent road vibration wind-down. Store the crank in the holder provided.
2. Before operating, identify the mounting style of your landing gear, inside or outside mount (see Figures 1 and 2).

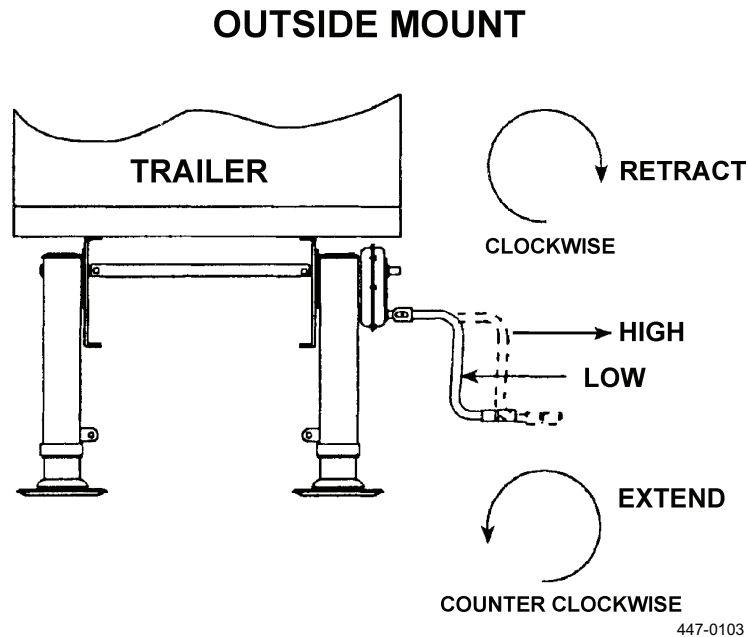
**Figure 1. Outside Mount.**

- a. Push crank handle in for low speed.
- b. Pull crank handle out for high speed.
- c. Turn crank:
 - (1) Counterclockwise = extend
 - (2) Clockwise = retract

OPERATION OF HOLLAND FORMULA 150 LANDING GEAR - CONTINUED

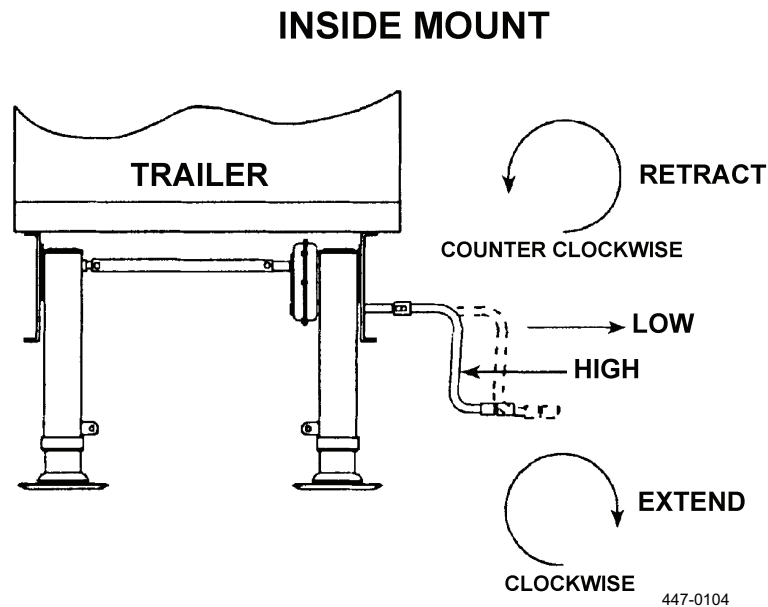

Figure 2. Inside Mount.

- a. Push crank handle in for high speed.
- b. Pull crank handle out for low speed.
- c. Turn crank:
 - (1) Counterclockwise = retract
 - (2) Clockwise = extend

REMOVE TRACTOR FROM SEMITRAILER

1. Position semitrailer so landing gear shoes will rest on a firm level surface when landing gear is extended.
2. Emplace ground boards under shoes.
3. Shift landing gear to high gear and extend landing gear until shoes contact ground boards.
4. Chock trailer tires.
5. Shift landing gear to low gear and lift semitrailer approximately 1 in. (2.54 cm).
6. Unlock fifth wheel, uncouple air lines, and drive the tractor out from under the semitrailer.

CONNECT TRACTOR TO SEMITRAILER

1. Ensure semitrailer is at a sufficient height to allow coupling of the tractor and semitrailer.
2. Chock trailer tires, front and rear of each tire.
3. Connect air lines from tractor to semitrailer, lock semitrailer brakes and back tractor under semitrailer, then lock fifth wheel.
4. Retract landing gears to fully retracted position.
5. Remove and properly store/secure chocks and ground boards. Engage crank handle to prevent wind down.
6. Store crank on the crank holder.

LUBRICATION

No additional grease is required.

TROUBLESHOOTING

CAUTION

- Landing gears are designed to meet T.T.M.A. recommended practice RP-4 and A.A.R.-931 requirements.
- When operating the landing gears, it is necessary to observe some cautions. By doing so you will ensure long trouble-free service by observing the following:
 - Do not over-extend or over-retract landing gears.
 - Never drop semitrailer on landing gears. Always extend landing gears until shoes contact ground, then lift semitrailer approximately 1 in. (2.54 cm) before removing tractor from semitrailer.
 - Always chock tires front and rear prior to coupling.
 - Always ensure that the landing gear shoes or footpads will rest on hard ground surface or concrete pad. If necessary, place shoes on a support plank to prevent the landing gears from sinking into the ground surface. (This is especially important with liquid cargo where a shift in the contents could overturn the semitrailer.) Use ground boards to ensure correct/safe coupling height and prevent shoes from sinking in soft ground.
 - Always retract landing gears fully before moving semitrailer.
 - Always store the crank on the crank holder after extending or retracting the landing gear.
 - Replace all damaged or missing parts.
 - Failure to replace worn or damaged riser nut and retracting screw assembly could cause a failure.

Landing Gears Hard to Crank

1. Cross driveshaft in a bind or tight between shafts. Bolts must be loose and cross driveshaft free to move in slots provided.
2. To determine which leg turns hard, remove cross driveshaft bolt and crank each leg on the jackshaft.
3. Check for inadequate lubrication (WP 0067).
4. Check for proper alignment. Legs must be timed together, parallel to each other, and perpendicular to the semitrailer crossmembers.

TROUBLESHOOTING - CONTINUED

5. Upper housing or retracting tube may be bent.
6. Landing gear jackshafts and/or shift shaft may be binding.
7. Retracting screw may be bent. Replace entire retracting leg assembly.

General**NOTE**

Replace the entire leg if these defects are found.

1. *Right-hand leg (gearbox leg) operates but left-hand leg does not move.* Broken cross driveshaft bolt or damaged cross driveshaft. Replace.
2. *Legs will not operate when turning jackshaft.* Damaged pinion or bevel gear.
3. *Right-hand leg will not operate; shift shaft will turn but jackshaft does not turn.* Damaged input, idler, and/or output gear.
4. *Leg locked and will not turn.* Bent retracting screw or damaged riser nut and screw. Replace entire retracting leg assembly.
5. *Right-hand leg will not stay fully shifted in low gear.* Shift lock ball and shift lock spring missing or damaged shift lock spring.
6. *Noisy gearbox.* Check that shift shaft movement is 1 in. (2.54 cm) when shifted between gears.

ALIGNMENT

Using a square, check that both landing gear legs are square with the semitrailer and parallel with each other as shown. Bent or damaged legs are an indication of possible damage to the lift screw, lift nut, or other internal components and should be replaced.

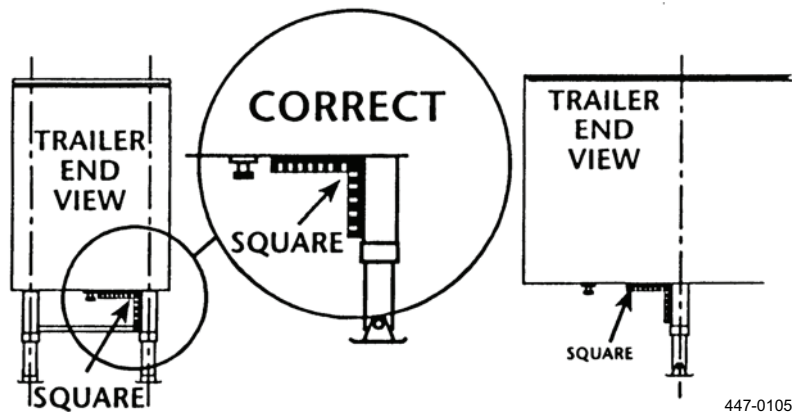

Figure 3. Correct Alignment.

END OF WORK PACKAGE

FIELD AND SUSTAINMENT MAINTENANCE**10 TIRE TIPS**

The following information was developed from commercial analysis and is presented to give a better understanding of the preventive maintenance.

1. A 15% under-inflation of a tire can result in:
 - a. An 8% drop in tread wear (mileage)
 - b. A 2.5% drop in fuel mileage
 - c. Proper inflation drastically reduces tire blowouts.
2. On the average, a tire in good condition, properly sealed, just sitting in place, will lose 2 psi (14 kPa) of air pressure per month.
3. Inflation pressure run just 10% under recommended tire pressure can cause casing to be unfit for re-treading.
4. Dual wheels:
 - a. Matching and matting are very important
 - b. Never use a bias ply and a radial tire on the same wheel position
5. Mismatching causes:
 - a. The larger diameter tire to become overloaded
 - b. Overheating
 - c. Loss of traction on smaller diameter tire
 - d. Irregular wear
 - e. Tread or ply separation
 - f. Tire body breaks
 - g. Blowouts
6. Repair punctures from inside of tire.
7. Remove the tire before the tread depth reaches 2/32 in. (1.6 mm).
8. Inflated tires can have an internal pressure force of 40,000 lb (275,800 kPa).
9. After just 50 to 100 miles (80 to 160 km) of service on a new vehicle or new tires, re-torque wheel nuts.
10. A tire cage is a must and could save a life.

END OF WORK PACKAGE

FIELD AND SUSTAINMENT MAINTENANCE**SEALED BRAKE INSTALLATION AND DISARMING****General Safety Precautions, Mechanical Release of Spring Brake (Gold Seal),
Combination Spring Brake Installation Instructions,
Disarming Introduction, Disarming Instructions, Supplementary Information**

GENERAL SAFETY PRECAUTIONS**WARNING**

- A spring brake contains a very powerful compression spring. Failure to comply with all of the following instructions may result in forceful release of the piggyback or spring chamber and its contents which could cause death, severe personal injury and/or property damage.
 - ALWAYS BLOCK WHEELS to prevent vehicle roll-away when performing any brake maintenance.
1. If spring brake shows structural damage, DO NOT cage the spring and DO NOT attempt to service it. Replace the complete unit. To prevent severe personal injury when removing an uncaged spring brake from a vehicle, cut the service push rod making sure to relieve all force on it. After cutting the push rod, remove the spring brake from the vehicle, then disarm the spring brake using a suitable safety chamber (see *Disarming Introduction* and *Disarming Instructions* in this work package).
 2. Never strike any part of the spring brake with a hammer or any other heavy object; structural damage may result.
 3. Do not drop spring brake, as compression spring may forcefully release.
 4. If air pressure is used to aid in the caging process, do not tighten the release tool more than finger tight. The air pressure must always be exhausted after the spring has been mechanically caged prior to disassembly.

GENERAL SAFETY PRECAUTIONS - CONTINUED

5. On all Haldex Anchorlok Gold Seal (Figure 1) and Life Seal (Figure 2) spring brakes, the emergency diaphragm cannot be replaced. Replace the complete piggyback (see *Mechanical Release of Spring Brake (Gold Seal)* in this work package for further instructions).

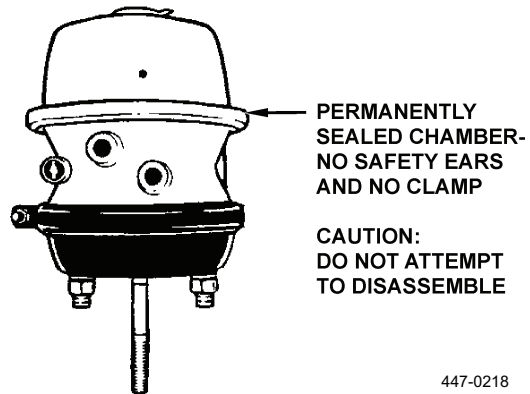

Figure 1. Gold Seal Spring Brake.

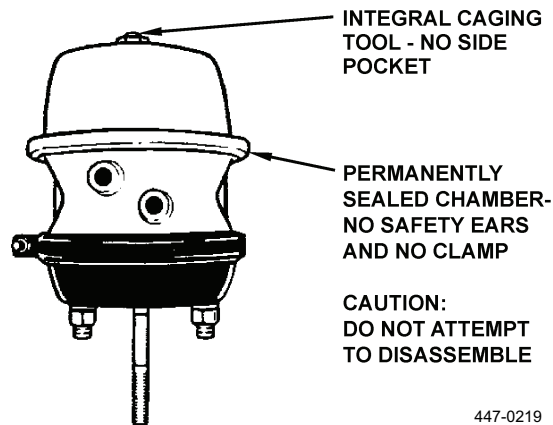

Figure 2. Life Seal Spring Brake.

6. Do not use any diaphragms with protrusions on the service side of any Haldex Anchorlok spring brake. Use of “piloted diaphragms” on the service side will result in a reduction of stroke length.
7. Long stroke spring brakes are easily identified by the square air ports on the adapter (Figure 3), and the letters “LS” stamped into the spring brake.

GENERAL SAFETY PRECAUTIONS - CONTINUED

Figure 3. Gold Seal and Life Seal Long Stroke Spring Brake.

END OF TASK**MECHANICAL RELEASE OF SPRING BRAKE (GOLD SEAL)****WARNING**

- DO NOT attempt to mechanically release (cage) the spring on a spring brake if it shows structural damage. Caging the spring or disassembly of the chamber may result in the forceful release of the spring chamber and its contents, which could cause death, severe personal injury, and/or property damage. Remove complete spring brake and replace with new unit.
- DISARM spring chamber before discarding old brake. To disarm, use a suitable safety chamber (see *Disarming Introduction* and *Disarming Instructions* in this work package). Failure to disarm assembly prior to disposal may, in time, result in spontaneous release of the spring chamber and its contents, causing death, personal injury, and/or property damage.

NOTE

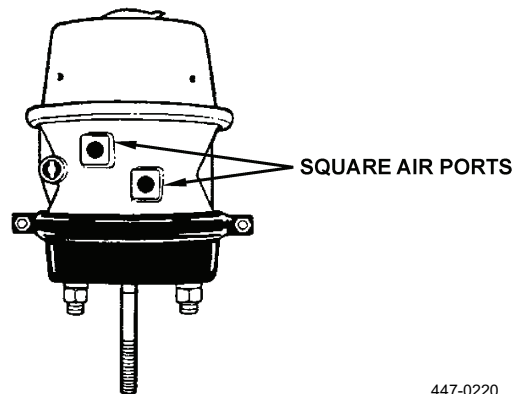
There are no safety ears or clamp on a sealed type brake.

MECHANICAL RELEASE OF SPRING BRAKE (GOLD SEAL) - CONTINUED**Cage Parking Brake Compression Spring (Release Parking Brake)****WARNING**

Always block wheels to prevent vehicle roll-away when performing any brake maintenance.
Failure to comply could cause injury or death to personnel.

1. Remove dust plug from release tool key hole in center of spring chamber (Figure 4).
2. Remove release tool assembly from side pocket of adapter (Figure 4).

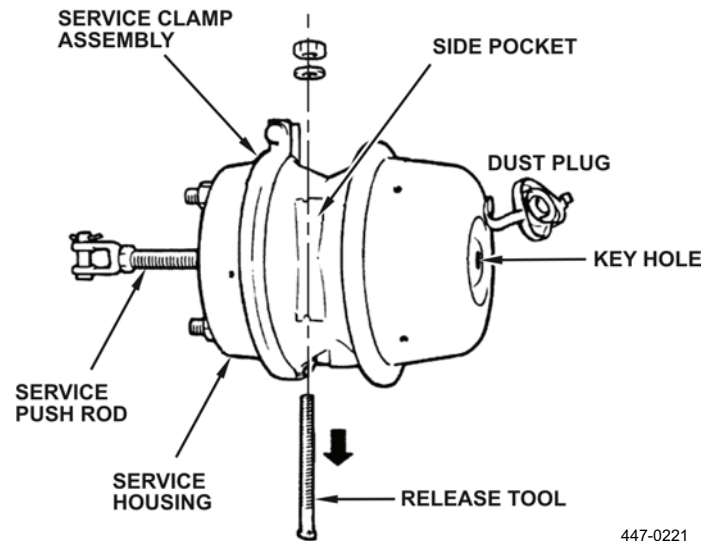

447-0221

Figure 4. Sealed Brake.

3. Insert release tool through key hole in chamber into the pressure plate (Figure 5, Arrow A).
4. Turn release stud 1/4 turn clockwise (Figure 5, Arrow B).
5. Pull on release tool to ensure stud crosspin is properly seated in the pressure plate.
6. Assemble release tool washer and nut on release stud; finger tighten only (Figure 5).

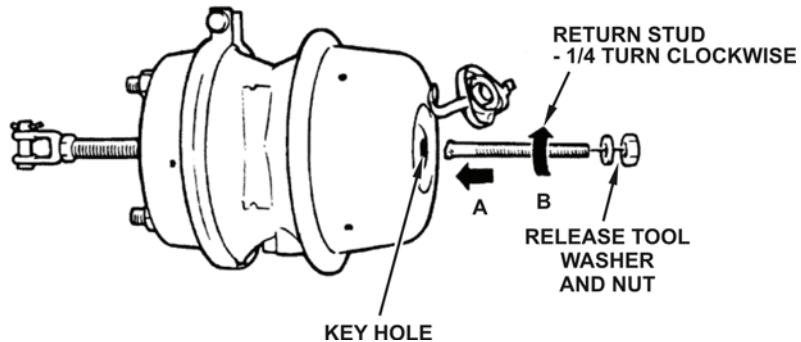

447-0222

Figure 5. Sealed Brake.

MECHANICAL RELEASE OF SPRING BRAKE (GOLD SEAL) - CONTINUED

WARNING

Step 7 only applies when spring brake is not pressurized. If air pressure is used to compress the spring, do not tighten release tool more than finger tight. Torquing the release tool nut while the spring brake is pressurized can cause pressure plate damage resulting in sudden release of the spring which could cause death or severe personal injury. Air pressure must be released after caging, prior to any disassembly.

7. Turn release tool nut clockwise with hand wrench (DO NOT USE HIGH-SPEED AND/OR POWER-DRIVEN IMPACT WRENCH) and make certain push rod is retracting (Figure 6).

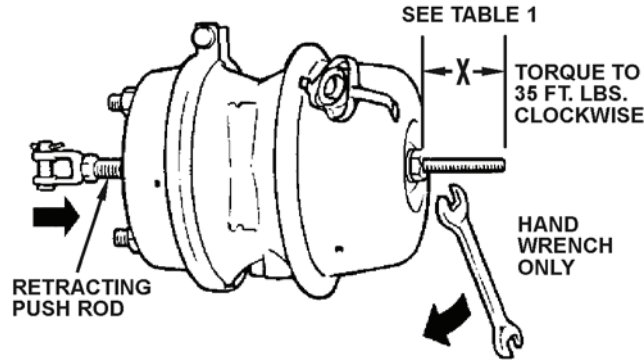

447-0223

Figure 6. Sealed Brake.

CAUTION

- Do not over-torque release tool assembly. Over-torquing release tool can cause pressure plate damage. GOLD-SEAL S-Cam type 35 lb-ft (47 Nm) Maximum, clockwise.
- To ensure the compression spring is fully caged, the release tool length (X dimension) (Figure 6) should measure as shown in Table 1.

NOTE

If dimension of release tool (X dimension) length is less than the minimum measurement, brake unit must be replaced.

Table 1. Release Tool Length.

MODEL	STROKE	X - MINIMUM
2424	2-1/4 in.	2.915 in. (740 mm)
2424LS	2-1/2 in.	2.915 in. (740 mm)
2430	2-1/4 in.	2.915 in. (740 mm)
2430LS	2-1/2 in.	2.915 in. (740 mm)
2430XLS	3 in.	3.463 in. (880 mm)
3030	2-1/2 in.	2.915 in. (740 mm)
3030LS	3 in.	3.537 in. (898 mm)
3636	3 in.	3.602 in. (915 mm)

MECHANICAL RELEASE OF SPRING BRAKE (GOLD SEAL) - CONTINUED**Pressurized Parking Brake Caging Recommendations**

1. DO NOT use a high-speed and/or power-driven impact wrench to cage brake.
2. Use air pressure (100 to 120 psi) in the chamber to collapse the compression spring before turning the release tool nut with a hand wrench. Proper caging will be complete when a slight resistance is felt after turning the release tool nut.

CAUTION

To ensure the compression spring is fully caged, the release tool length (X dimension) (Figure 6) should measure as shown in Table 1.

END OF TASK**COMBINATION SPRING BRAKE INSTALLATION INSTRUCTIONS****Installation Preparation**

1. Spring brake must be caged prior to performing installation procedures. If brake is not caged, *Mechanical Release of Spring Brake (Gold Seal)* in this work package for safety instructions and mechanical release of spring brake.
2. In an effort to maximize the life of Haldex Anchorlok spring brakes, Haldex Neway recommends the following brake mounting guidelines when installing Haldex Anchorlok spring brakes on your vehicle(s).

Cut Push Rod to Correct Installation Length**WARNING**

Place blocks under wheels to prevent vehicle roll-away before removing spring brake actuators. Failure to comply could cause injury or death to personnel.

CAUTION

Before installing a new combination spring brake, it is necessary to determine the correct service push rod length to ensure proper alignment for efficient operation of the spring brake (Figure 7). Failure to comply could cause damage to equipment.

NOTE

- Units are furnished with a universal fully threaded push rod and must be cut to the correct length.
 - If spring brake unit being replaced is not available to take measurements from, follow the procedures listed under step 5 below.
1. Remove worn or non-functional spring brake unit from vehicle. Determine manufacturer and model of unit to be replaced. Refer to that manufacturer's service manual for caging and removal instructions.
 2. Make sure the spring chamber of the removed actuator is fully released (power spring caged) and the service brake push rod is fully retracted to zero stroke position (i.e., brake fully released).

COMBINATION SPRING BRAKE INSTALLATION INSTRUCTIONS - CONTINUED

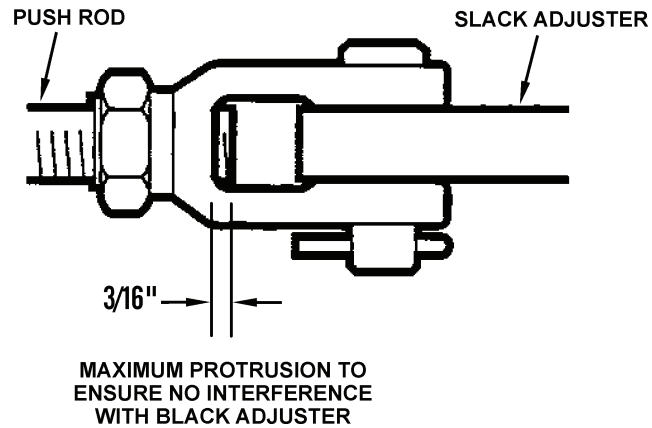

447-0225

Figure 7. Sealed Brake.

3. Measure and record the "Y" and "Z" dimensions from unit to be replaced (Figure 8).
 - a. "Y" dimension = Dimension from bottom of actuator to end of piston rod.
 - b. "Z" dimension = Dimension from bottom of actuator to centerline of clevis pin.
4. Take "Y" dimension (Figure 8) from the removed unit and mark push rod of new unit to be cut.

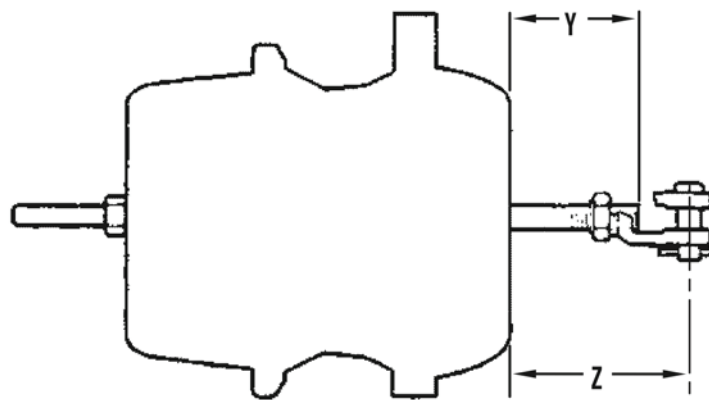

447-0224

Figure 8. Sealed Brake.

COMBINATION SPRING BRAKE INSTALLATION INSTRUCTIONS - CONTINUED

NOTE

Step 5 lists the procedures to determine correct push rod length when the spring brake being replaced is not available. Go to step 6 if correct push rod length is already determined.

- To determine the correct push rod length of the brake to be installed, measure "B" dimension as shown (Figure 9) and subtract the setup stroke as listed in Table 3. With the spring brake fully caged: "B" Dimension Minus Setup Stroke = Push Rod Length including Clevis (Figure 10).

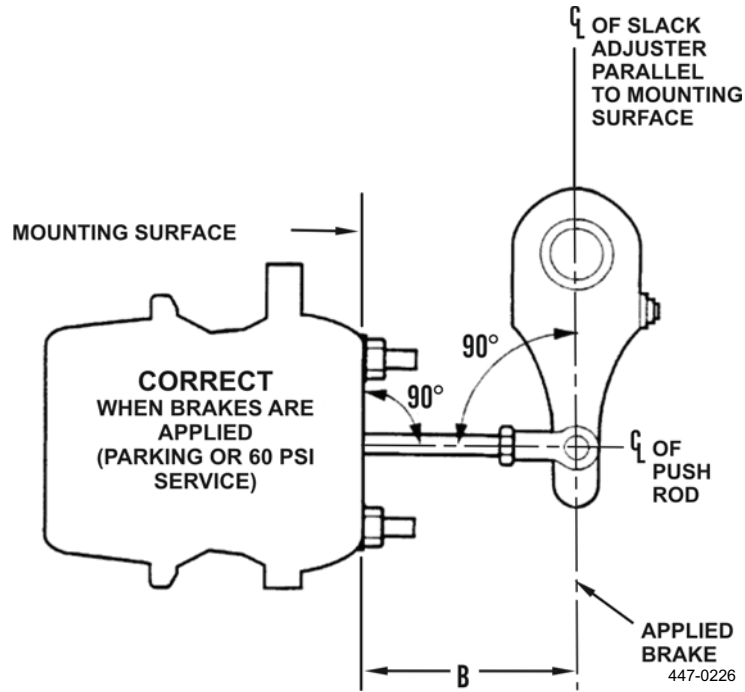

Figure 9. Sealed Brake.

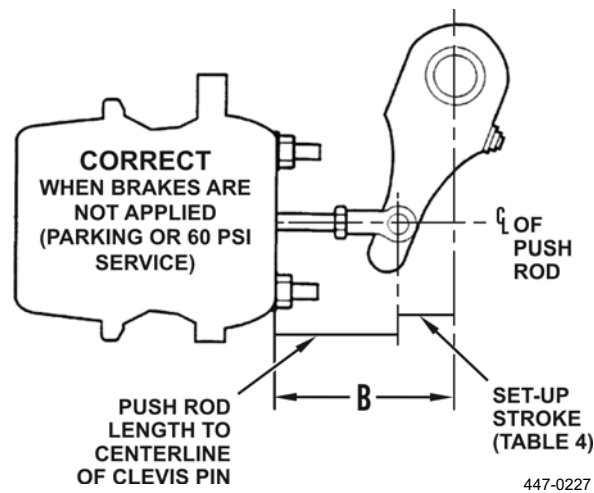

Figure 10. Sealed Brake.

COMBINATION SPRING BRAKE INSTALLATION INSTRUCTIONS - CONTINUED**NOTE**

- Setup stroke is only to establish push rod length.
 - For a typical Type 30 spring brake, if dimension “B” (Figure 9) = 5.0 in., setup stroke = 1-1/2 in. (Table 3). The push rod length from mounting face to centerline of main clevis pin should measure: 5 minus 1-1/2 = 3-1/2 in. with the spring brake caged (Figure 10).
6. Before marking push rod to be cut on new unit, be sure the spring chamber is caged and the push rod is fully retracted to the zero stroke position. Refer to *Mechanical Release of Spring Brake (Gold Seal)* in this work package.

NOTE

When determining the push rod cut-off length, the length of the threaded rod protruding between the clevis legs must not exceed 3/16 in. to insure no interface with the operation of the stack adjuster (Figure 7).

7. Thread clevis jam nut past the mark on push rod. Align bottom edge of nut with mark to use as a guide for cutting. Use a sharp hack-saw and cut push rod on the mark.
8. After cutting rod, thread jam nut off to clean up threads.

COMBINATION SPRING BRAKE INSTALLATION INSTRUCTIONS - CONTINUED**Mounting Spring Brake to Mounting Bracket****CAUTION**

Always mount brake chamber directly to bracket. If a reinforcement plate is necessary, see *Attachment Guidelines* in this work package for plate attachment. **DO NOT** insert spacers, washers, or shims between mounting bracket and brake housing (Figure 11). Consult the bracket manufacturer for your application if a reinforcement plate may be necessary.

NOTE

In some cases it may be necessary to rotate air ports.

When attaching spring brakes to mounting brackets, the following checks and instructions should be performed:

1. Mounting brackets must be inspected to assure that bracket surface is free from debris, burrs, cracks, weld spatter and is flat within 1/64 in. (0.4 mm) (Figure 11).
2. Attach spring brake directly to mounting bracket on axle. Fasten with mounting hardware (Figure 11). Torque to specifications listed in Table 2.

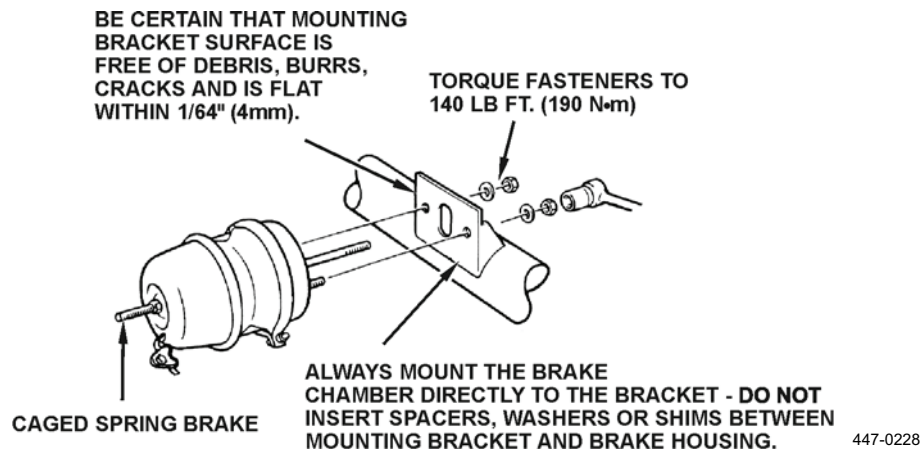

Figure 11. Sealed Brake.

COMBINATION SPRING BRAKE INSTALLATION INSTRUCTIONS - CONTINUED

Attachment Guidelines

When attaching a reinforcement plate to the brake mounting bracket face, the following guidelines must be followed:

1. Attach .25 in. (6 mm) steel plate 7 in. x 7 in. (178 mm x 178 mm) square, to brake mounting bracket face. Secure with two 5/8 in. or M16 bolts, washers, and nuts, and torque to 50 lb-ft (67.5 Nm) (Figure 12).

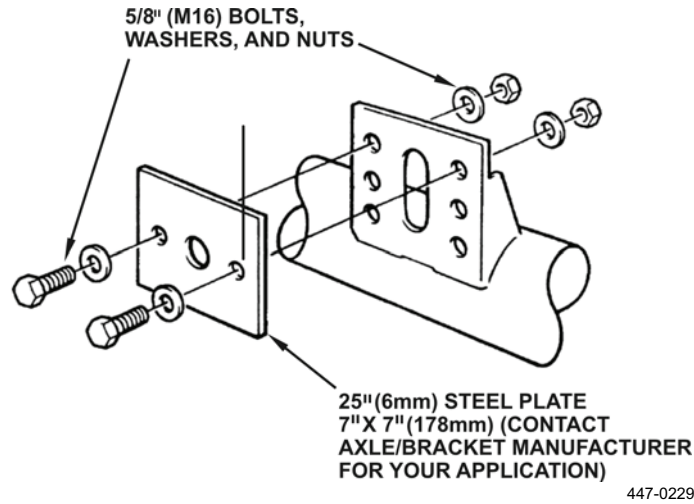

Figure 12. Sealed Brake.

2. Weld reinforcement plate to brake mounting bracket (see Figure 13 for suggested weldment locations). For exact location and weld size, refer to axle manufacturer’s guidelines. Allow welds to cool and remove bolts (Figure 13).

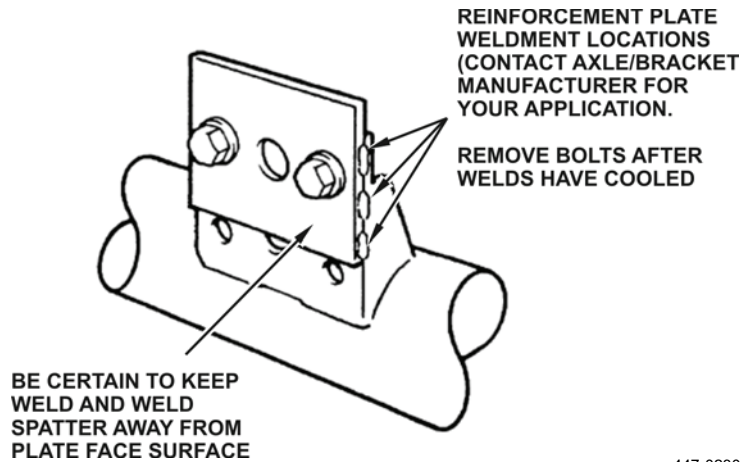

Figure 13. Sealed Brake.

COMBINATION SPRING BRAKE INSTALLATION INSTRUCTIONS - CONTINUED

- Attach spring brake directly to new reinforcement plate. Fasten with mounting hardware (Figure 14). Torque to specifications listed in Table 2.

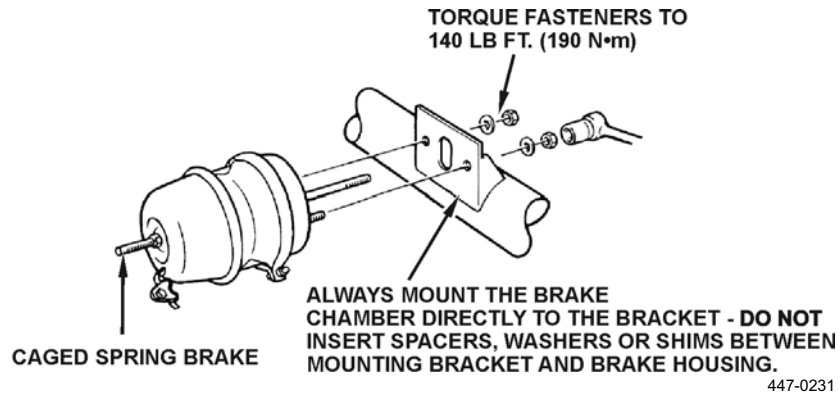

Figure 14. Sealed Brake.

Table 2. Installation Torque Values.

	TORQUE
Mounting Hardware	130-150 lb-ft (177 - 203 Nm)
Jam Nut	15-25 lb-ft (20 - 34 Nm)
Ports	10 lb-ft max (14 Nm max)
LIFE SEAL - Release Tool Nut	55 lb-ft (74 Nm)
GOLD SEAL - Release Tool Nut	25-35 lb-ft (34 - 47 Nm)
GOLD SEAL - Release Tool Nut (in side pocket)	5-8 lb-ft (7 - 11 Nm)
Carriage Bolt Nuts (for clamps)	20-30 lb-ft (27.1 - 40.7 Nm)

COMBINATION SPRING BRAKE INSTALLATION INSTRUCTIONS - CONTINUED**Attach Clevis and Air Lines**

1. Thread jam nut back onto the push rod a sufficient length to allow assembly of the clevis.
2. Thread clevis onto the push rod. Clevis from removed unit may be reused provided clevis pin hole is not worn. Adjust clevis to the same "Z" dimension as measured from the removed unit (Figure 8).
3. Hold clevis to prevent it from turning and tighten jam nut against clevis to torque specifications (Table 2). Clevis must be adjusted so that it has full thread engagement on the push rod (from flush to 3/16 in. protrusion) (Figure 7).
4. Connect the service and emergency air lines to the proper air ports. Torque to specifications listed in Table 2.
5. Connect clevis to the slack adjuster using clevis and cotter pins (Figure 15), and uncage the spring brake. Refer to uncaging procedures.

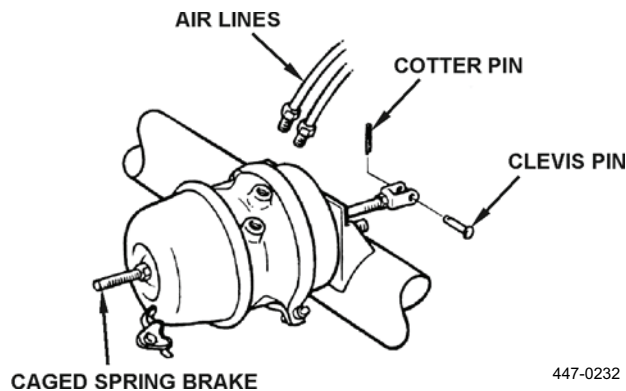
**Figure 15. Sealed Brake.****CAUTION**

If push rod is not long enough to reach slack adjuster mounting hole, DO NOT physically pull push rod out to reach mounting hole. Doing so could cause damage to equipment.

6. Adjust the slack adjuster to the listed setup stroke (Table 3) (Figure 16).

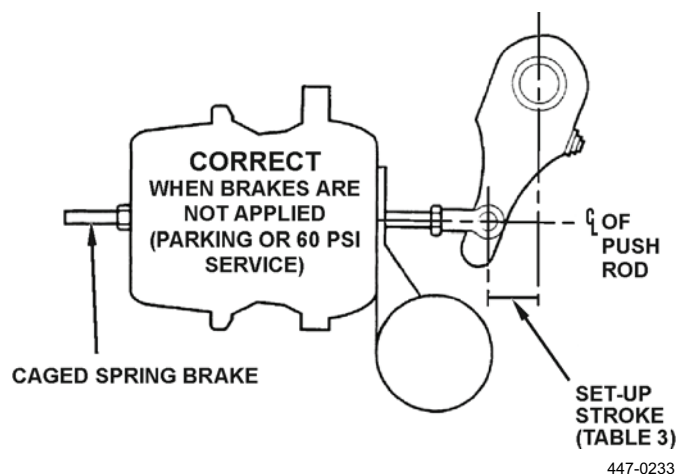
**Figure 16. Sealed Brake.****END OF TASK**

COMBINATION SPRING BRAKE INSTALLATION INSTRUCTIONS - CONTINUED

Verify Proper Installation

1. With the brake applied, the following conditions must occur:
 - a. Push rod 90 degrees to the centerline of slack adjuster.
 - b. Push rod 90 degrees to the mounting face of the spring brake (Figure 17).

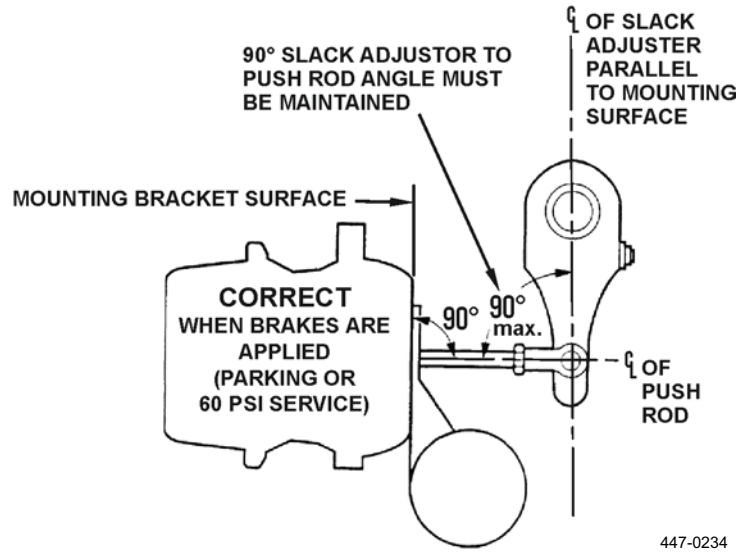

Figure 17. Sealed Brake.

Table 3. Stroke Values.

Chamber Type	Available Stroke (Inches)	Recommended Chamber Stroke Range		Set-Up Stroke Applied Braked*†
		Minimum	Maximum	
09	1-3/4 in.	(Should be as short a stroke as possible without brake dragging.)	-1 in.	1-3/8 in.
12	1-3/4 in.		-1 in.	1-3/8 in.
16	2-1/4 in.		-1-1/2 in.	1-3/8 in.
20	2-1/4 in.		-1-1/2 in.	1-3/8 in.
20XLS**	3 in.		-2-1/4 in.	1-3/4 in.
24	2-1/4 in.		-1-1/2 in.	1-3/8 in.
24LS**	2-1/2 in.		-1-3/4 in.	1-1/2 in.
24XLS**	3 in.		-2-1/4 in.	1-3/4 in.
30	2-1/2 in.		-1-3/4 in.	1-1/2 in.
30LS**	3 in.		-2-1/4 in.	1-3/4 in.
36	3 in.		-2-1/4 in.	1-3/4 in.

* Stroke length measured by applying parking brake or 60 PSIG service brake application.

** Long Stroke.

† Typical setup stroke values.

Notice: For special applications, consult vehicle, brake or slack adjuster manufacturers.

COMBINATION SPRING BRAKE INSTALLATION INSTRUCTIONS - CONTINUED**WARNING**

Incorrect push rod slack adjuster setup will result in improper brake operation, causing injury to personnel and damage to equipment.

2. If the setup results in the conditions depicted in Figure 18 and Figure 19, the spring brake is misaligned and must be corrected by one or more of the following procedures:

- a. **Figure 18.**

- (1) Shorten push rod.
- (2) Align spring brake on mounting bracket.
- (3) Count clevis in proper slack adjuster hole.

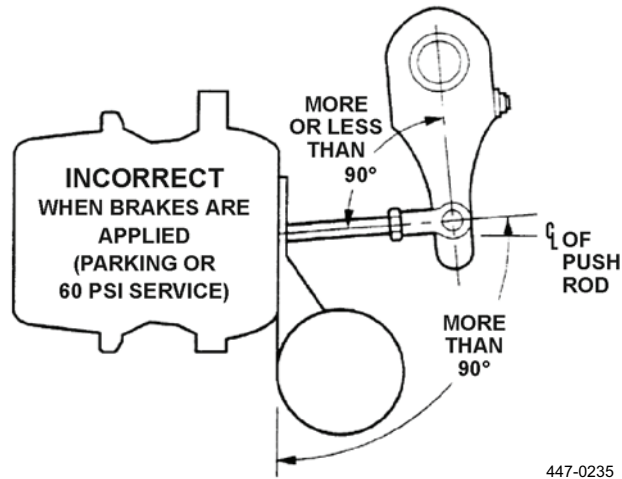
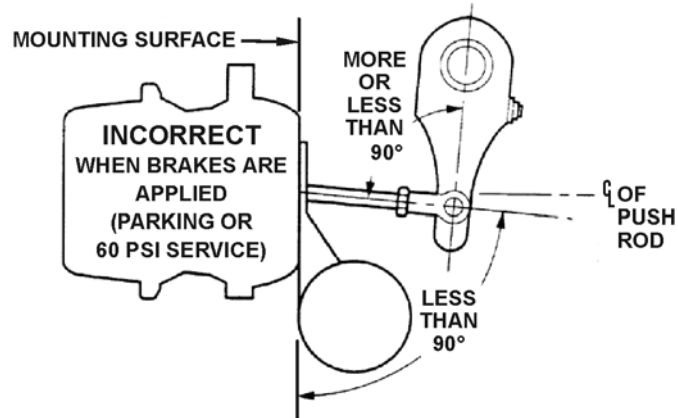

Figure 18. Sealed Brake.

COMBINATION SPRING BRAKE INSTALLATION INSTRUCTIONS - CONTINUEDb. **Figure 19.**

- (1) Lengthen push rod.
- (2) Align spring brake on mounting bracket.
- (3) Mount clevis in proper slack adjuster hole.



447-0236

Figure 19. Sealed Brake.**NOTE**

If misalignment cannot be corrected, consult with foundation brake manufacturer for verification of correct mounting bracket position.

3. Once the spring brake and push rod are set properly (Figure 17), release the brakes and follow vehicle manufacturer's instructions for brake adjustment.

END OF TASK

COMBINATION SPRING BRAKE INSTALLATION INSTRUCTIONS - CONTINUED**Special Instructions for Gold Seal Brakes****WARNING**

After installation, check for proper emergency operation, service operation, and brake adjustment. Failure to comply could cause injury to personnel and damage to equipment.

CAUTION

Removing the bottom-most plug will allow the spring chamber to breathe and allow for drainage of condensation. Spring brake longevity will be adversely affected if the bottom-most plug is not removed. All other vent holes must be plugged. Additional plugs (Part Number 999 90 28) can be purchased from your local Haldex Anchorlok distributor.

Remove bottom-most vent hole plugs from mounted spring brakes (Figure 20 and Figure 21).

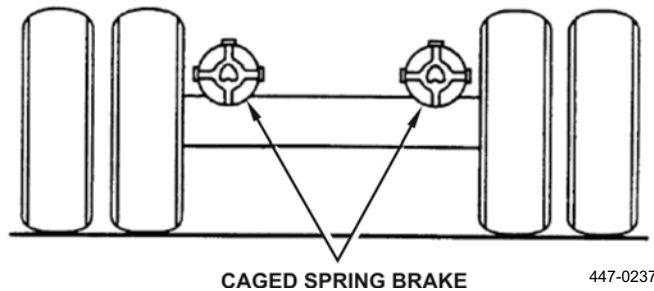

Figure 20. Gold Seal Only.

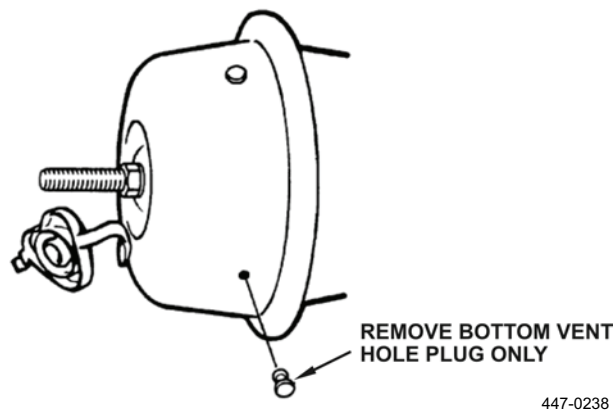

Figure 21. Gold Seal Only.

DISARMING INTRODUCTION

The proper disposal of old spring brake chambers is a concern of commercial industry and should be a concern of all maintenance shops. ALL retired spring brake chambers (actuators) must be safely disarmed before they are disposed of to prevent serious personal injury from accidental sudden release of the high-energy spring (as much as 2,700 lb-ft [12,010 Nm]) in the packing chamber.

It is recommended that the coils of the power spring be cut with an acetylene gas torch prior to disposal. This simple procedure renders the power spring inoperable, permitting the chamber to be safely discarded.

Reference Figure 22 with material list for fabrication of the Spring Brake Disarming Chamber as engineered by Lear Siegler Truck Products Corporation.

WARNING

Spring air brake chambers should never be rebuilt. Never attempt to loosen or remove the housing retaining clamp(s) bolts or repair the chamber in any way. Serious injury or death will occur.

- This disarming chamber is to be fabricated at the Direct Support or higher level.
- An annual inspection of this disarming chamber will be accomplished at the DOL or Depot Level QA/QC as is the case for tire cages.
- DOL will certify inspection of the disarming chamber by stamping or applying data plate.
- There will be NO substitution of ANY materials used to fabricate this chamber. Materials and welding standard/locations specified on the drawing are to be used in this fabrication. This is a safety device.
- Never operate an acetylene gas torch without wearing proper clothing and eye protection.

Maintenance Levels (Figure 22)

Chamber Fabrication: Direct Support and above

Disarming Procedures: Organizational and above

DISARMING INTRODUCTION - CONTINUED

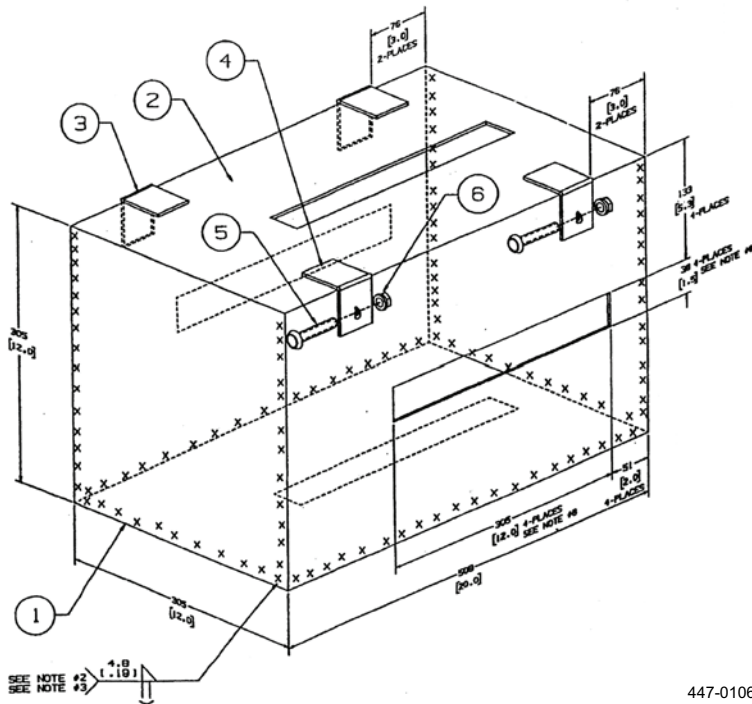

447-0106

Figure 22. Disarming Sealed Brake.

Notes:

1. Drill holes and use manufacturer's suggested fasteners to mount hinges and hasps or weld in places.
2. Weld where indicated by XXXXX.
3. Do not weld lid to body.
4. Paint to suit.
5. Material:
 - a. 2 pcs. 12 x 12 x 1/4 in. thick
 - b. 4 pcs. 12 x 20 x 1/8 in. thick
 - c. HR or CF steel
6. Cut 12 x 1.5 in. (305 x 38 mm) slots in material as shown four places.

Table 4. Key to Callouts.

ITEM	QTY	DESCRIPTION
1	1	Body
2	1	Lid
3	2	6 in. heavy-duty wrought steel hinge
4	2	1-3/4 in. wide heavy-duty wrought steel hinged hasp
5	2	3/8 in. carriage bolt (11MO52)
6	2	3/8 in. carriage nut (11MO51)

DISARMING INSTRUCTIONS

1. Place the single/piggyback or combination/tandem spring brake chamber in the fabricated/inspected disarming chamber. Air brake chamber should be uncaged with caging bolt removed.
2. Position the air brake chamber so the spring brake head can be easily accessed through the slots in the disarming chamber. If the air brake chamber does not fit in the disarming chamber, it may be necessary to cut off the service push-rod. Close the hinged access door of the disarming chamber, and lock hasps with bolts and nuts.
3. Through one of the slot openings in the disarming chamber use an acetylene gas torch to cut a hole (1-1/2 to 2 in. [3.8 to 5.1 cm]) in the air brake chamber head to expose the power spring coil. DO NOT cut the power spring coil. See Figure 22 for approximate location to cut hole on housing side.
4. Repeat step 3 for opposite side of the spring brake head. Cutting two holes opposite each other provides the torch with sufficient oxygen for cutting the power spring coil.
5. Cutting the first power spring coil may produce a low-pitched “pop” or may cause the spring brake chamber to jump in the disarming chamber. Repeat this cutting process through the slot opening on the opposite side of the disarming chamber.

WARNING

- DO NOT cut the spring brake chamber clamp bolts before cutting the power spring coils. The spring coils MUST be cut FIRST. If this WARNING is NOT heeded, the spring will prematurely release 2,000 lb of pressure, and become an unexpected projectile that could cause injury or death to personnel and damage to the equipment.
 - Do not place your hands or fingers inside the disarming chamber.
6. To make sure you have completely cut the power spring coils, use a screwdriver or similar tool to ensure coils are loose inside the head of the spring brake chamber. If the coils can be moved, the spring brake chamber has been rendered safe and can be properly discarded.

END OF TASK

SUPPLEMENTARY INFORMATION

1. Many manufacturers do not rebuild or condone the use of rebuilt air brake chambers. This is because they are very important safety devices that actuate foundation brakes and perform vital parking and emergency brake functions. Because they operate in the worst possible environments under the most severe conditions, it is impossible to accurately determine the condition and service life remaining in critical components such as the non-pressure housing (mounting base), flange case (center section), power spring, and center push-rod seal. These are all components that are typically “cleaned up” and/or repainted and reused in rebuilt actuators. With a rebuilt actuator, you have no reliable way of knowing which components have been replaced and how long the unit can be expected to last.
2. If you do not have the capability to fabricate this disarming chamber and inspect it for safety, there is a commercially built disarming chamber available from Jack Garner & Sons Welding which is AWS Code welded, has positive locking, and is portable. This disarming box runs approximately \$330. They may be reached at 717-367-2638 or 717-653-6551, FAX: 717-367-7906, E-Mail: jack.garner@garnerwelding.com. Their product may be viewed at: <http://www.garnerwelding.com>.

END OF WORK PACKAGE

FIELD AND SUSTAINMENT MAINTENANCE
HUB PILOTED DISC WHEELS

TORQUE SPECIFICATIONS
10 STUD HUBS

RECOMMENDED TORQUE: 450 - 500 Ft. Lb.

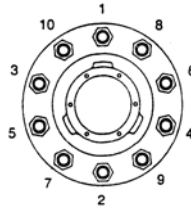

10 STUD

Recheck Torque after first 50 to 100 miles of service.

447-0107

Figure 1. Torque Specifications.

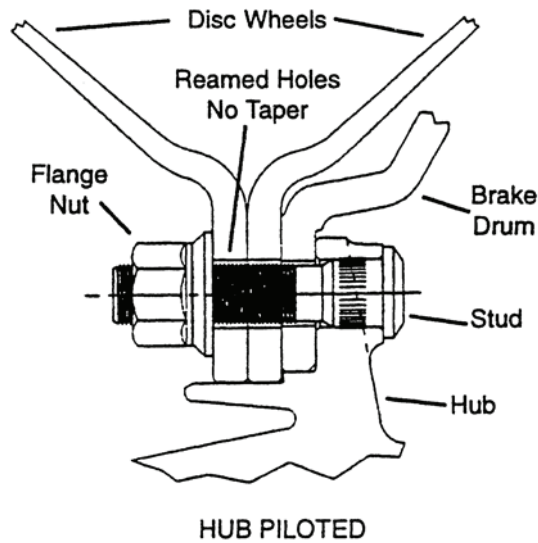

447-0108

Figure 2. Hub Piloted Disc Wheel Mounting.

END OF WORK PACKAGE

FIELD AND SUSTAINMENT MAINTENANCE
OSHA STANDARD MULTI- AND SINGLE-PIECE WHEEL

OSHA STANDARD 29 CFR PART 1910.177**Servicing Multi-Piece and Single-Piece RIM Wheels****1. Scope.**

- a. This section applies to the servicing of multi- and single-piece rim wheels used on large vehicles such as trucks, tractors, trailers, buses, and off-road machines. It does not apply to the servicing of rim wheels used on automobiles, or on pickup trucks and vans utilizing automobile tires or truck tires designated "LT."
- b. This section does not apply to employers and places of employment regulated under the Construction Safety Standards, 29 CFR Part 1926; the Agriculture Standards, 29 CFR part 1915; or the Longshoring Standards, 29 CFR part 1916.
- c. All provisions of this section apply to the servicing of both single-piece rim wheels and multi-piece rim wheels unless designated otherwise.

2. Definitions.

- a. **Barriers.** A fence, wall, or other structure or object placed between a single-piece rim wheel and an employee during tire inflation, to contain the rim wheel components in the event of the sudden release of the contained air of the single-piece rim wheel.
- b. **Charts.** The U.S. Department of Labor, Occupational Safety and Health Administration (OSHA) publications entitled *Demounting and Mounting Procedures for Truck/Bus Tires* and *Multi-Piece Rim Matching Chart*, the National Highway Traffic Safety Administration (NHTSA) publications entitled *Demounting and Mounting Procedures for Truck/Bus Tires* and *Multi-Piece Rim Matching Chart*, or any other poster which contains at least the same instructions, safety precautions, and other information contained in the charts that is applicable to the types of wheels being serviced.
- c. **Installing a Rim Wheel.** Transfer and attachment of an assembled rim wheel onto a vehicle axle hub.
- d. **Removing.** The opposite of installing.
- e. **Mounting a Tire.** The assembly or putting together of the wheel and tire components to form a rim wheel, including inflation. Demounting means the opposite of mounting.
- f. **Multi-Piece Rim Wheel.** The assemblage of a multi-piece wheel with the tire tub and other components.
- g. **Multi-Piece Wheel.** A vehicle wheel consisting of two or more parts, one of which is a side or locking ring designed to hold the tire on the wheel by interlocking components when the tire is inflated.
- h. **Restraining Device.** An apparatus such as a cage rack or assemblage of bars and other components that will constrain all rim wheel components during an explosive separation of a multi-piece wheel, or during the sudden release of the contained air of a single-piece rim wheel.
- i. **Rim Manual.** A publication containing instructions from the manufacturer or other qualified organization for correct mounting, demounting, maintenance, and safety precautions peculiar to the type of wheel being serviced.
- j. **Rim Wheel.** An assemblage of tire, tube and liner (where appropriate), and wheel components.
- k. **Service or Servicing.** The mounting and demounting of rim wheels and related activities such as inflating, deflating, installing, removing, and handling.
- l. **Service Area.** That part of an employer's premises used for the servicing of rim wheels, or any other place where an employee services rim wheels.
- m. **Single-Piece Rim Wheel.** The assemblage of the single-piece rim wheel with the tire and other components.

OSHA STANDARD 29 CFR PART 1910.177 - CONTINUED

- n. **Single-Piece Wheel.** A vehicle consisting of one part, designed to hold the tire on the wheel when the tire is inflated.
 - o. **Trajectory.** Any potential path or route that a rim wheel component may travel during an explosive separation, or the sudden release of the pressurized air, or an area at which an air blast from a single-piece rim wheel may be released. The trajectory may deviate from paths which are perpendicular to the assembled position of the rim wheel at the time of separation or explosion (Figure 1).
 - p. **Wheel.** That portion of the rim wheel which provides the method of attachment of the assembly to the axle of a vehicle and also provides the means to contain the inflated portion of the assembly (i.e., the tire and/or tube).
3. **Employee Training.**
- a. The employer shall provide a program to train all employees who service rim wheels in the hazards involved in servicing those rim wheels and the safety procedures to be followed.
 - b. The employer shall ensure that no employee services any rim wheel unless the employee has been trained and instructed in correct procedures of servicing the type of wheel being serviced, and in the safe operating procedures described in steps 6 and 7 of this section.
 - c. Information to be used in the training program shall include, at a minimum, the applicable data contained in the charts (rim manuals) and the contents of this standard.
 - d. Where an employer knows or has reason to believe that any of his employees is unable to read and understand the charts or rim manual, the employer shall ensure that the employee is instructed concerning the contents of the charts and rim manual in a manner which the employee is able to understand. The employer shall ensure that each employee demonstrates and maintains the ability to service rim wheels safely, including performance of the following tasks:
 - (1) Demounting of tires (including deflation);
 - (2) Inspection and identification of the rim wheel components;
 - (3) Mounting of tires (including inflation with a restraining device or other safeguard required by this work package);
 - (4) Use of the restraining device or barrier, and other equipment required by this work package;
 - (5) Handling of rim wheels;
 - (6) Inflation of the tire when a single-piece rim wheel is mounted on a vehicle;
 - (7) An understanding of the necessity of standing outside the trajectory, both during inflation of the tire and during inspection of the rim wheel, following inflation, and;
 - (8) Installation and removal of rim wheels.
 - e. The employer shall evaluate each employee's ability to perform these tasks and to service rim wheels safely, and shall provide additional training as necessary to ensure that each employee maintains his or her proficiency.
4. **Tire Servicing Equipment.**
- a. The employer shall furnish a restraining device for inflating tires on multi-piece wheels.
 - b. The employer shall provide a restraining device or barrier for inflating tires on single-piece wheels.
 - c. Restraining devices and barriers shall comply with the following requirements:
 - (1) Each restraining device or barrier shall have the capacity to withstand the maximum force that would be transferred to it during a rim wheel separation occurring at 150 percent of the maximum tire specification pressure for the type of rim wheel being serviced.
 - (2) Restraining devices and barriers shall be capable of preventing the rim wheel components from being thrown outside or beyond the device or barrier for any rim wheel positioned within or behind the device.

OSHA STANDARD 29 CFR PART 1910.177 - CONTINUED

- (3) Restraining devices and barriers shall be visually inspected prior to each day's use and after any separation of the rim wheel components or sudden release of container air. Any restraining device or barrier exhibiting damage such as the following defects shall be immediately removed from service:
 - (a) Cracks at welds;
 - (b) Cracked or broken components;
 - (c) Bent or sprung components caused by mishandling, abuse, tire explosion, or rim wheel separation;
 - (d) Pitting of components due to corrosion; or
 - (e) Other structural damage which would decrease its effectiveness.
 - d. Restraining devices or barriers removed from service shall not be returned to service until they are repaired and reinspected. Restraining devices or barriers requiring structural repair such as component replacement or rewelding shall not be returned to service until they are certified by either the manufacturer or a Registered Professional Engineer as meeting the strength requirements of step 4c.
 - e. The employer shall furnish and ensure that an air line assembly consisting of the following components be used for inflating tires:
 - (a) A clip-on chuck;
 - (b) An in-line valve with a pressure gauge or a pre-settable regulator; and
 - (c) A sufficient length of hose between the clip-on chuck and in-line valve (if one is used) to allow the employee to stand outside the trajectory.
 - f. Current charts or rim manuals containing instructions for the type of wheels being serviced shall be available in the service area.
 - g. The employer shall furnish and ensure that only tools recommended in the rim manual for the type of wheel being serviced are used to service rim wheels.
5. **Wheel Component Acceptability.**
- a. Multi-piece wheel components shall not be interchanged except as provided in the charts or in the applicable rim manual.
 - b. Multi-piece wheel components and single-piece wheels shall be inspected prior to assembly. Any wheel or wheel component which is bent out of shape, pitted from corrosion, broken, or cracked shall not be used and shall be marked or tagged unserviceable and removed from the service area. Damaged or leaky valves shall be replaced.
 - c. Rim flanges, rim gutters, rings, bead seating surfaces, and the bead areas of tires shall be free of any dirt, surface rust, scale, or loose flaked rubber build-up prior to mounting and inflation.
 - d. The size (bead diameter and tire/wheel widths and type of both the tire and the wheel) shall be checked for compatibility prior to assembly of the rim wheel.
6. **Safe Operating Procedures - Multi-Piece Rim Wheels.** The employer shall establish a safe operating procedure for servicing multi-piece rim wheels and shall ensure that employees are instructed in and follow that procedure. The procedure shall include at least the following elements:
- a. Tires shall be completely deflated before demounting by removal of the valve core.
 - b. Tires shall be completely deflated by removing the valve core before the rim wheel is removed from the axle in either of the following situations:
 - (1) When the tire has been driven under-inflated at 80% or less of its recommended pressure, or
 - (2) When there is obvious or suspected damage to the tire or wheel components.
 - c. Rubber lubricant shall be applied to bead and rim mating surfaces during assembly of the wheel and inflation of the tire, unless the tire or wheel manufacturer recommends against it.

OSHA STANDARD 29 CFR PART 1910.177 - CONTINUED

- d. If a tire on a vehicle is under-inflated but has more than 80 percent of the recommended pressure, the tire may be inflated while the rim wheel is on the vehicle provided remote control inflation equipment is used, and no employees remain in the trajectory during inflation.
 - e. Tires shall be inflated outside a restraining device only to a pressure sufficient to force the tire bead onto the rim ledge and create an airtight seal with the tire and bead.
 - f. Whenever a rim wheel is in a restraining device the employee shall not rest or lean any part of his body or equipment on or against the restraining device.
 - g. After tire inflation, the tire and wheel components shall be inspected while still within the restraining device to make sure that they are properly seated and locked. If further adjustment to the tire or wheel components is necessary, the tire shall be deflated by removal of the valve core.
7. **Safe Operating Procedure - Single-Piece Rim Wheels.** The employer shall establish a safe operating procedure for servicing single-piece rim wheels and shall ensure that employees are instructed in and follow that procedure. The procedure shall include at least the following elements:
- a. No attempt shall be made to correct the seating of side and lock rings by hammering, striking, or forcing the components while the tire is pressurized.
 - b. Cracked, broken, bent, or otherwise damaged rim components shall not be reworked, welded, brazed, or otherwise heated.
 - c. Whenever single-piece rim wheels are being handled, employees shall stay out of the trajectory (Figure 3) unless the employer can demonstrate that performance of the servicing makes the employee's presence in the trajectory necessary.
 - d. No heat shall be applied to a single-piece wheel or wheel component.
 - e. Tires shall be completely deflated by removal of the valve core before demounting.
 - f. Mounting and demounting of the tire shall be done only from the narrow ledge side of the wheel. Care shall be taken to avoid damaging the tire breads while mounting tires on wheels. Tires shall be mounted only on compatible wheels of matching bead diameter and width.
 - g. Nonflammable rubber lubricant shall be applied to bead and wheel mating surfaces before assembly of the rim wheel, unless the tire or wheel manufacturer recommends against the use of any rubber lubricant.
 - h. If a tire changing machine is used, the tire shall be inflated only to the minimum pressure necessary to force the tire bead onto the rim ledge while on the tire changing machine.
 - i. If a bead expander is used, it shall be removed before the valve core is installed and as soon as the rim wheel becomes airtight (the tire bead slips onto the bead seat).
 - j. Tires may be inflated only when contained within a restraining device, positioned behind a barrier, or bolted on the vehicle with the lug nuts fully tightened.
 - k. Tires shall not be inflated when any flat, solid surface is in the trajectory and within one foot of the sidewall.
 - l. Employees shall stay out of the trajectory when inflating a tire.
 - m. Tires shall not be installed to more than the inflation pressure stamped in the sidewall unless a higher pressure is recommended by the manufacturer.
 - n. Tires shall not be inflated above the maximum pressure recommended by the manufacturer to seat the tire bead firmly against the rim flange.

OSHA STANDARD 29 CFR PART 1910.177 - CONTINUED

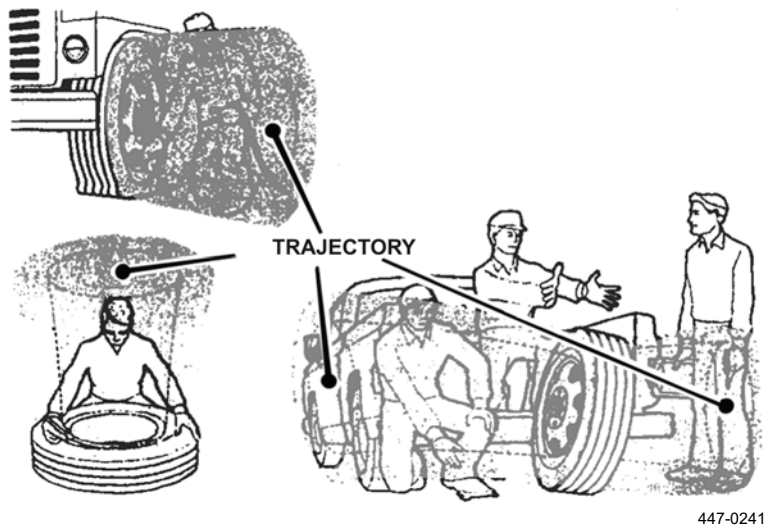

Figure 1. Trajectory.

Ordering Information for the OSHA Charts

OSHA has printed two charts entitled *Demounting and Mounting Procedures for Truck/Bus Tires* and *Multi-Piece Rim Matching Chart*, as part of a continuing campaign to reduce accidents among employees who service large vehicle rim wheels.

Reprints of the charts are available through the Occupational Safety and Health Administration (OSHA) Area and Regional Offices. The address and telephone number of the nearest OSHA office can be obtained by looking in the local telephone directory under U.S. Government, I.S. Department of Labor, Occupational Safety and Health Administration. Single copies are available without charge.

Individuals, establishments, and other organizations desiring single or multiple copies of these charts may order them from the OSHA Publications Office, U.S. Department of Labor, Room N3101, Washington, DC 20210. Telephone (202) 219-4667.

END OF WORK PACKAGE

FIELD AND SUSTAINMENT MAINTENANCE

TROUBLESHOOTING HUBS

Table 1. Troubleshooting Hubs Using Piloted Disc Wheels.







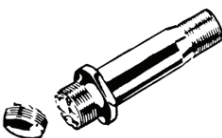

EXAMPLE	PROBLEM	CAUSE	SOLUTION
	Broken studs	1. Loose capnuts 2. Overloading	Replace the broken stud and the stud on each side of the broken stud. If more than two studs are broken, replace the entire set.
	Stripped threads on studs or capnuts	Excessive torque	Replace stud and/or capnut and re-torque to specifications.
	Damaged inner or outer capnuts	1. Loose wheel 2. Overloading	Replace capnuts. Check for proper stud standout and re-torque to specifications.
	Damaged threads on stud or cap nut	Sliding wheel on threads	Replace studs or capnuts per installation instructions.
	Worn mounting face on hub	1. Loose capnuts 2. Overloading	Replace hub following assembly procedures. When reassembling inboard-mounted brake drum to hub, tighten back nuts to specifications.

Table 1. Troubleshooting Hubs Using Piloted Disc Wheels - Continued.

EXAMPLE	PROBLEM	CAUSE	SOLUTION
	Uneven tire wear	1. Improper tire alignment	Align per wheel service instructions.
		2. Loose bearing adjustment	Check bearing for wear and replace or readjust as required.
		3. Loose or worn suspension bushings	Check with suspension manufacturer.
		4. Low tire pressure	Inflate to recommended pressure.
	Worn or elongated stud holes	1. Loose capnuts 2. Overloading	Replace hub following assembly procedures. When reassembling inboard-mounted brake drum to hub, tighten nuts to specifications.
	Damaged stud and groove	Loose back nuts	Replace hub following assembly procedures. When reassembling inboard-mounted brake drum to hub, tighten back nuts to specifications.
	Stud standout wrong	Improper stud or wrong brake drum	Replace studs or drum. Recommended standout is 1.31 to 1.44 in. (3.32 to 3.65 cm). When changing from composite to cast drum, studs may have to be changed.
	Rust streaks	Loose capnuts	Follow torque specifications.

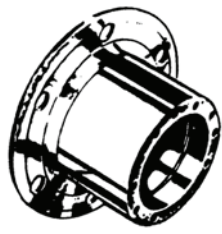
END OF TASK

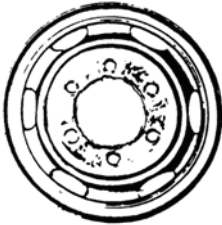
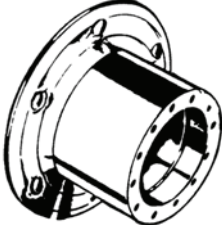
END OF WORK PACKAGE

**FIELD AND SUSTAINMENT MAINTENANCE
TROUBLESHOOTING WHEEL PROBLEMS**

Table 1. Troubleshooting Wheel Problems.



EXAMPLE	PROBLEM	CAUSE	SOLUTION
	Mutilated threads	Sliding wheel across studs during wheel assembly	Replace studs. Follow proper wheel assembly procedure.
	Loose drum	<ol style="list-style-type: none"> 1. Body length of stud too long. 2. Back nut not firmly sealed against drum 	Replace stud. Be sure to use stud with correct body length.
	Loose inner wheel	Too much stud standout from mounting face of hub, permitting wheel nut to bottom out	Replace stud. Be sure stud is correct length.
	Broken studs	<ol style="list-style-type: none"> 1. Loose cap nuts 2. Overloading 	Replace stud. Follow proper torque procedure.
	Stripped threads	Excessive torque	Replace stud. Follow proper torque procedure.

Table 1. Troubleshooting Wheel Problems - Continued.







EXAMPLE	PROBLEM	CAUSE	SOLUTION
	Worn stud groove	<ol style="list-style-type: none"> 1. Stud turning in groove 2. Insufficient torque on back nut 	Replace hub and follow proper torque procedure.
	Worn mounting face on hub	Loose wheel assembly	Replace hub and follow proper torque procedure.
	Metal build-up around stud holes, out-of-round, or worn stud holes	Loose capnuts	Replace wheel. Follow proper torque procedure.
	Rust streaks from stud holes	Loose capnuts	Check complete assembly. Replace damaged parts. Follow proper torque procedure.
	Cracked rims	Overload or overinflation	Replace wheel. Match wheel ratings against actual load and inflation pressures required.

Table 1. Troubleshooting Wheel Problems - Continued.

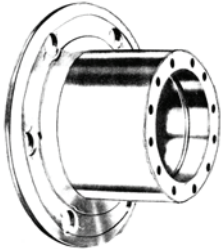
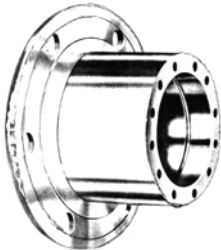
EXAMPLE	PROBLEM	CAUSE	SOLUTION
	Rim corrosion	<ol style="list-style-type: none"> 1. Poor maintenance 2. Water in air supply with tubeless tires 	<ol style="list-style-type: none"> 1. If corrosion is slight, wire brush and repaint. 2. If corrosion is severe, replace wheel.
	Wheel cracks: Hand hole-to-hand hole Hand hole-to-stud hole Hand hole-to-rim	Overloading	Check actual load on axle. Install new wheel according to loading requirements.
	Rust streaks	Loose capnuts	Follow torque specifications.

END OF TASK

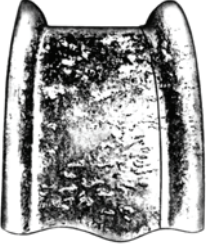
END OF WORK PACKAGE

FIELD AND SUSTAINMENT MAINTENANCE**TROUBLESHOOTING BRAKE DRUMS**

TROUBLESHOOTING INFORMATION

Replacement of the brake drum is required if any of the following conditions exist:

1. Brake drum is cracked.
2. The brake surface is heat checked, grooved, or worn beyond the re-bore limit of 0.080 in. (2.03 mm) or maximum diameter.
3. The back plate is cracked.
4. The bolt holes are elongated.
5. Brake drum is known to have been severely overheated.
6. Brake drum is out-of-round enough that turning would exceed re-bore limit.

NOTE

Brake drums should be replaced in pairs to achieve the same braking power on the axle.

Table 1. Troubleshooting Brake Drums.



EXAMPLE	PROBLEM	CAUSE	SOLUTION
	<p>Cracked brake drum (new)</p> <p>Cracked brake drum (used)</p> <p>Cracked brake drum (used, low mileage)</p>	<ol style="list-style-type: none"> 1. Manufacturing 2. Heat checks connect together and grow through drum section 3. Improper shoe contact 	<ol style="list-style-type: none"> 1. Replace brake drum. 2. Replace brake drum. Check brake balance, brake return springs, brake adjustment, and lining type within vehicle combination. 3. Replace brake drum. Shoes must contact drum at the center of the shoe.
	<p>Light heat check</p>	<p>Normal condition</p>	<p>Does not impair brake performance. Brake drum may be turned with normal limit. See maintenance instructions regarding turning of brake surface.</p>
	<p>Heavy heat check</p>	<p>Imbalanced brake system, dragged brakes, or driver abuse caused by constant heating and cooling of brake surface.</p>	<p>Replace brake drum. Check brake balance, brake return springs, brake adjustment, and lining type within vehicle combination.</p>
	<p>Fine grooves</p>	<p>Abrasive material or poor quality brake lining</p>	<p>Re-bore brake drum within normal limits or replace the drum and lining. See maintenance instructions regarding turning of brake surface.</p>
	<p>Grooves coinciding with rivet holes</p>	<p>Loose rivets or bolts or foreign material collecting in rivet holes</p>	<p>Re-bore brake drums within normal limits or replace the drum and lining. See maintenance instructions regarding turning of brake surface.</p>

Table 1. Troubleshooting Brake Drums - Continued.



EXAMPLE	PROBLEM	CAUSE	SOLUTION
	Grooves along edges of lining	Abrasive material collecting at edges of lining	Dust shield may cause or cure this problem. Re-bore brake drum within normal limits. See maintenance instructions regarding turning of brake surface.
	Blue or discolored brake surface	Excessive heat from dragging brakes or brake imbalance between tractor and trailer	Re-bore brake drum within normal limits or replace. Look for weak or broken return springs or binding brake actuation system. See maintenance instructions regarding turning of brake surface.
	Heat spotted or hard spots in brake surface	High localized heating and cooling cycles	Grind hard spot and re-bore brake drum within normal limits. See maintenance instructions regarding turning of brake surface.
	Out-of-round: balance	Balance weight has fallen off or a balanced drum was not specified	Re-bore brake drum. Specify balanced brake drums when ordering replacement.
	Out-of-round: variation in diameter Out-of-round: concentricity Excessive wear	<ol style="list-style-type: none"> 1. Heat distortion 2. Improper fit to pilot or improper seating on wheel or hub 3. Abrasive material between lining and drum or poor quality lining 	<ol style="list-style-type: none"> 1. Re-bore brake drum within normal limits or replace. See maintenance instructions regarding turning of brake surface. 2. Clean all mounting surfaces. Check for correct fit and clearance to wheel. 3. Check maximum diameter and re-bore within limit or replace. See maintenance instructions regarding turning of brake surface.

Table 1. Troubleshooting Brake Drums - Continued.

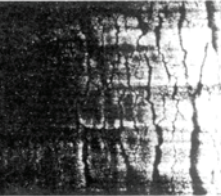
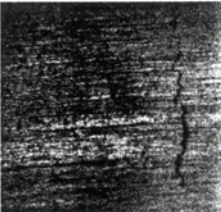
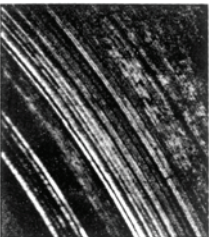

EXAMPLE	PROBLEM	CAUSE	SOLUTION
	Grease-stained drums	Leaking oil seal or improper lubrication of brake components	Repair source of oil or grease leak. Clean the brake drums and replace the linings.
	Polished brake surface	<ol style="list-style-type: none"> 1. Normal condition for non-asbestos linings 2. Improperly cured brake linings 	Remove glaze with emery cloth or re-bore drum within normal limits. See maintenance instructions regarding turning of brake surface.
	Faded or diminished brake powder	High temperature in brake system, improperly adjusted brakes or inferior brake lining	Check brake drum, brake lining condition, brake adjustment, and brake balance. Avoid operating conditions or loads that create excessive brake temperature.
	Noise, chatter, or pulsating during brake application	Heat spotted drums, grease-stained drums, loose brake drum or brake components	Brake drum should be removed and checked for one or more of these conditions and the appropriate action (as described in this section) should be taken to resolve the condition.
	Crack between the pilot and a bolt hole	<ol style="list-style-type: none"> 1. Improper handling 2. Installation on dirty hub 	Replace brake drum. Replace brake drum. Clean the hub prior to installing replacement brake drum.

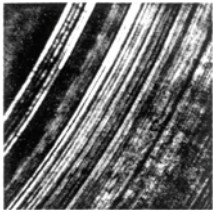
Table 1. Troubleshooting Brake Drums - Continued.

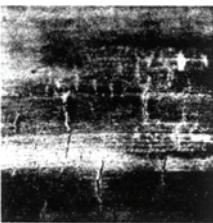
EXAMPLE	PROBLEM	CAUSE	SOLUTION
	<p>Mounting flange separated from hoop section of the brake drum</p>	<ol style="list-style-type: none"> 1. Installation on dirty hub 2. Wheel hitting the drum 	<ol style="list-style-type: none"> 1. Replace brake drum. Clean the hub prior to installing replacement brake drum. 2. Wrong application. Replace brake drum with correct part number.

END OF TASK

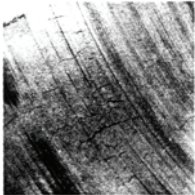
END OF WORK PACKAGE

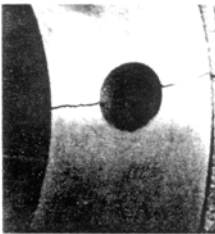
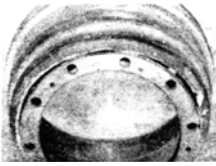
FIELD AND SUSTAINMENT MAINTENANCE
TROUBLESHOOTING SPRING PARKING BRAKE

NOTE

Points covered in this troubleshooting guide are limited and apply to service brake and spring parking brake actuators.

INSUFFICIENT SERVICE BRAKE APPLICATION WHEN SERVICE PEDAL IS DEPRESSED

1. Restricted air flow or low air pressure to service chamber.
2. Worn brake lining or drums worn or cracked.
3. Improper brake adjustment (auto or manual slack adjusters).
4. Automatic adjusters not operating properly.
5. Improper service pushrod-to-slack-adjuster alignment or geometry (refer to vehicle manufacturer's recommendations).
6. Bent or broken cam brackets or chamber mounting brackets (cam brakes).
7. Ruptured diaphragm.
8. Air leak in lines, fittings, or valves and at actuator clamp ring.
9. Improper pushrod length (not to vehicle manufacturer's specifications).

INSUFFICIENT SPRING BRAKE APPLICATION

NOTE

While most of the causes listed for "insufficient service brake application when service pedal is depressed" will apply here, there are additional items which should be checked.

1. Broken power spring.
2. Insufficient size of spring brake or improper output force.
3. Spring brake was not fully released during brake adjustment.

EXCESSIVE LEAKAGE, SERVICE BRAKE APPLIED

1. Leaking brake chamber diaphragm.
2. Leaking hoses, tubes, or fittings.
3. Faulty valves.

WARNING

Do not loosen or remove chamber clamp ring. Injury or death to personnel could result.

4. Inspect for leakage at clamp ring. Tighten to 25 to 30 lb-ft (33.9 to 40.7 Nm) torque if leakage is found.

EXCESSIVE LEAKAGE, SPRING BRAKES RELEASED BY AIR

1. Leaking diaphragm or main seal in spring section.
2. Leaking pushrod seal.
3. Leaking hoses, tubes, or fittings.

DRAGGING BRAKES**Service Brakes**

1. Broken return spring in service section.
2. Service application air not exhausting properly or fast enough.
3. Clogged parts or defective valves.
4. Restricted or collapsed hose or tubing.
5. Broken brake shoe return springs.
6. Camshaft linkage binding.
7. Auto slack and adjusters over-adjusting.

Spring Brakes

1. Leaking diaphragm or seal in spring brake section.
2. Service or parking system pressure leakage causing spring brakes to partially apply.
3. Broken return spring in spring brake section (double diaphragm type).

SERVICE BRAKES APPLY WHEN SPRING BRAKES ARE RELEASED BY AIR

1. Leaking pushrod seal between spring brake and service section.
2. Improper plumbing.

LEAK THROUGH SERVICE EXHAUST PORTS, SPRING BRAKES RELEASED BY AIR

Leaking pushrod seal between spring brake and service section.

SPRING BRAKES WILL NOT RELEASE (NORMAL OPERATION)

1. Insufficient air pressure.
2. Air leaks in spring brake air system.
3. Restrictions in spring brake air system.
4. Ruptured diaphragm and/or seal in spring brake section.
5. Broken spring causing malfunction.

SPRING BRAKES CANNOT BE MECHANICALLY RELEASED

1. Release bolt stripped or broken.
2. Broken internal release mechanism.
3. Broken power spring blocking full release.

END OF TASK**END OF WORK PACKAGE**

FIELD AND SUSTAINMENT MAINTENANCE**SKF SCOTSEAL**

PURPOSE

1. The purpose of this work package is to help you reduce premature wheel end failures by tracking down their causes. A SKF wheel end system is made up of high quality parts designed for reliability and long life. When a part doesn't reach its intended service life, it suffers premature failure, and this calls for an investigation.
2. Tracking wheel end failure requires a planned, consistent approach to repair and maintenance, like the sample procedures shown here. Investigating damage to a SKF Scotseal or Scotseal Plus wheel seal requires taking the seal apart. In these unitized designs, the seal and sealing surface are inside, making it easy, once the surface is exposed, to track what has happened.
3. Reading the failure modes of bearings and hub caps is simply matching up the visible damage to a short list of causes. If questions arise that aren't covered here, contact your SKF sales representative. We'll be glad to provide further help.
4. For proper installation instructions on Scotseal, Scotseal Plus, bearings, and accessories, the following materials are available: Fleet Self Study Guide (457935) and Bearing Self Study Guide (457640).

PROCEDURE**Inspect for Indications of Leakage**

1. Under vehicle inspection.
 - a. Grease present past the seal.
 - b. Grease contaminated hub, brake hardware, and brake shoes.
2. External leakage
 - a. Grease present around hub cap exterior.
 - b. Grease present on wheels and exterior axle areas by dust shields.

Disassembling the Wheel End**WARNING**

Block wheels. Support vehicle on stands. Failure to do so could cause injury or death to personnel and damage to equipment.

1. Check condition of hub cap. Check flange.
2. Check bolts and hub flange area on drive axle.

Remove Hub Cap

1. Check condition of lubricant.
 - a. Cloudy or milky indicates water.
 - b. Shiny indicates bearing wear.
 - c. Gritty or sandy indicates contamination.
 - d. Burnt smell indicates overheating.

PROCEDURE - CONTINUED

2. Check condition of fastening system.
 - a. Verify end-play measurement before removing fastener.
 - b. Examine outer nut and return spring.

Remove Outer Bearing

1. Remove wheel or hub assembly, using a wheel dolly.
2. Check spindle.
 - a. Threads damaged.
 - b. Chamfer damaged
3. Set bearings aside for inspection.
4. Remove seal.
 - a. Check hub.
 - b. Condition of chamfer.
 - c. Nicks, burrs, or damage.
5. These are the key seal failure modes to look for. They will account for virtually all of your premature seal failures:

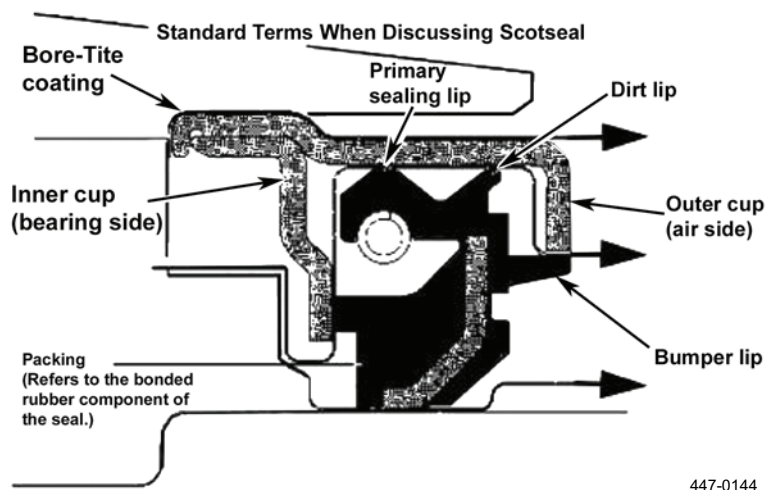
**Figure 1. Standard Terms.**

- a. Improper installation
- b. Wrong tool or no tool used.
- c. Cocked installation.
- d. Improper bearing adjustment.
- e. Seal spinning on spindle.
 - (1) Hit spindle.
 - (2) Spindle imperfections.
- f. Hub imperfections.
- g. Installed over a wear ring.

PROCEDURE - CONTINUED**How to Remove a Scotseal****NOTE**

The Scotseal maintains a metal-to-metal contact between the seal outside diameter and the hub bore surface, as well as a metal contact between the packing I.D. and the spindle.

1. The first step is removing the Scotseal from the hub. You do this by inserting a pry bar (crow's foot) between the seal and the bearing cone. The bar should rest on the inner race to avoid damaging the bearing.
2. Do not clean the seal. In this case, dirt can be helpful in providing valuable clues.

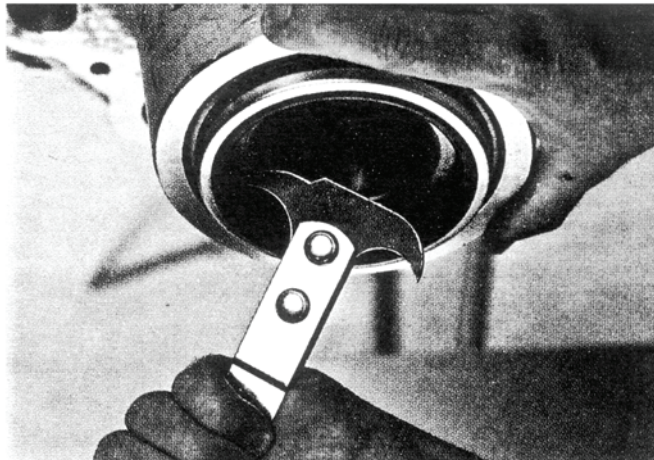

447-0145

Figure 2. Scotseal Removal.**END OF TASK****INSTALLATION**

1. Thoroughly clean wheel hub and seal bore.
2. Thoroughly clean spindle and spindle threads.
3. Pre-lubricate the inner bearing with GAA.

CAUTION

Seal must be squarely seated when bottomed in hub bore. Check for freedom of movement by manually moving the seal packing up and down. A free movement of the packing is required for proper bearing end play adjustment.

4. Place seal onto hub bore and insert drive tool into the seal. Hold tool handle firmly and straight. Drive seal into hub bore with firm hammer strokes.

END OF TASK**END OF WORK PACKAGE**

FIELD AND SUSTAINMENT MAINTENANCE**BEARING REMOVAL AND INSTALLATION****Removal, Inspection, Installation**

REMOVAL

1. Remove hub/wheel assembly from vehicle in accordance with recommended practices.
2. Remove inboard and outboard bearing cones and set aside for inspection.
3. Using a mild steel drift or cup driver, carefully drive out bearing cups.

CAUTION

- Caution should be used when driving bearing cups, as drifts and other tools can damage bearings.
- Drifts can damage hub bearing bores. Be careful not to score bores while removing cups, especially when using aluminum hubs.



447-0255

Figure 1. Removal.**END OF TASK**

INSPECTION (REF. TM 9-214)

1. Inspect the hub bearing bores and shoulders for damage. The bores should be smooth and free from scoring, burrs, indications of cup spinning, or other forms of damage. Remove any burrs or raised areas using emery cloth, a file, or other appropriate tool.
2. Measure the bearing cup bore and compare to manufacturer specifications.



447-0256

Figure 2. Inspection.

3. Inspect bearing cups and cones for damage. Bearings should be free from chips, contamination, and signs of excessive wear or excessive heat. Refer to bearing damage analysis literature for identifying possible bearing issues.
4. Inspect axle spindle bearing journals for any signs of damage or excessive wear. Remove any raised areas or burrs using emery cloth, file, or other appropriate tool.
5. Journals should be measured and compared with manufacturer specifications.



447-0257

Figure 3. Inspection.**END OF TASK**

INSTALLATION

1. Thoroughly clean bearing cups and cones prior to installation.

WARNING

Do not use compressed air to spin bearing rollers as injury to personnel may result if cage does not retain the rollers.

2. Lightly coat the outside of bearing cups with oil.

CAUTION

- Caution should be used when driving bearing cups, as drifts and other tools can damage bearings.
- NEVER use a bearing cone to drive a bearing cup. This can damage the bearings and cause premature failure.

NOTE

If a cup driver is not available, a mild steel drift can be used to install bearing cups.

3. Using a cup driver, carefully drive bearing cups into hub bearing bores. Be sure to drive cup firmly against cup shoulder in hub.
4. Use a feeler gauge to check for gaps between cup and shoulder.
5. Inspect the bearing cups to ensure no damage occurred during installation.
6. Lubricate bearing cones according to recommended practices and proceed with installation of wheel assembly.



447-0258

Figure 4. Installation.

END OF TASK**END OF WORK PACKAGE**

FIELD AND SUSTAINMENT MAINTENANCE
ENHANCED EASY-STOP TRAILER ABS WITH PLC

ENHANCED EASY-STOP TRAILER ABS WITH PLC

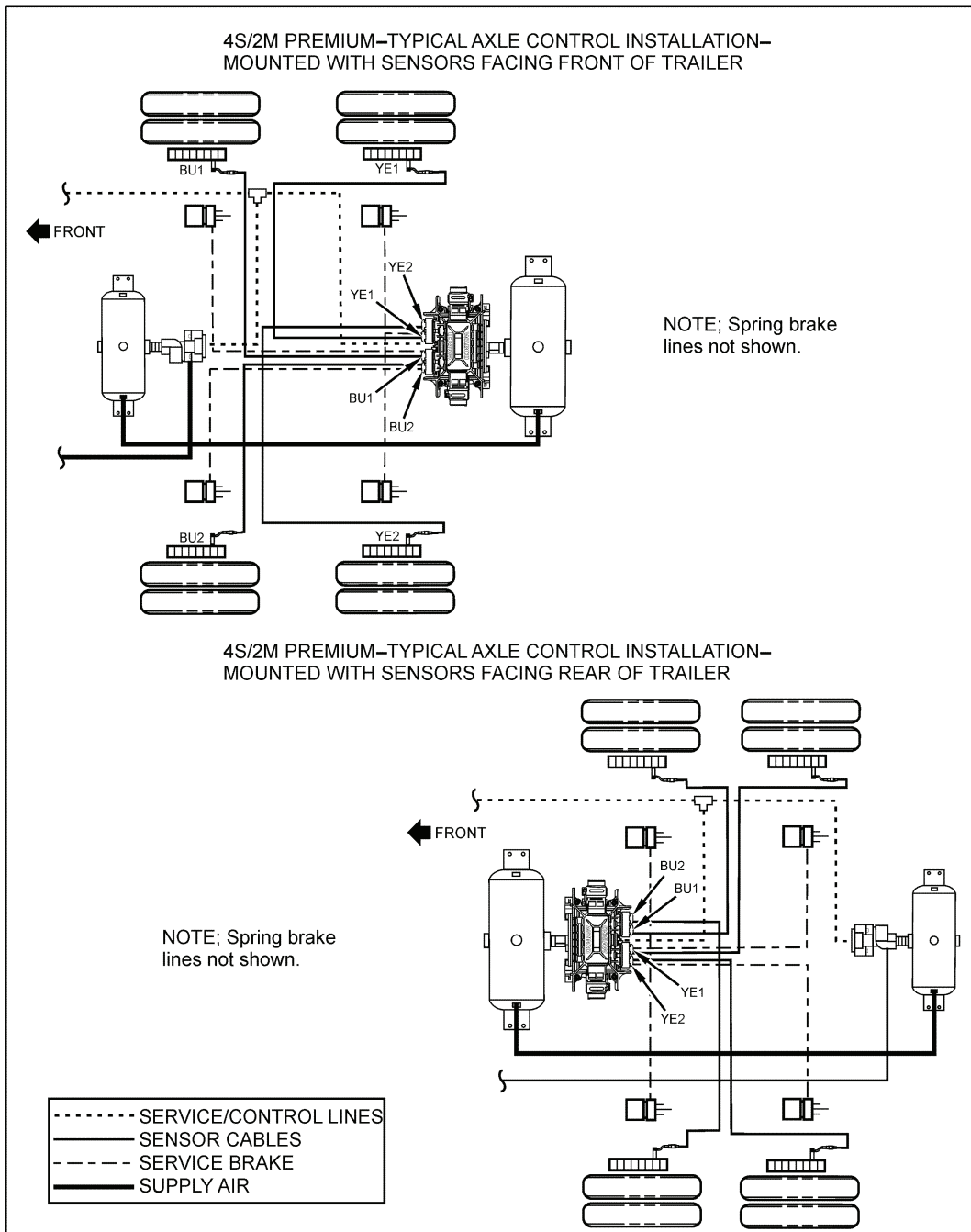

447-0146

Figure 1. System Configurations.

ENHANCED EASY-STOP TRAILER ABS WITH PLC - CONTINUED

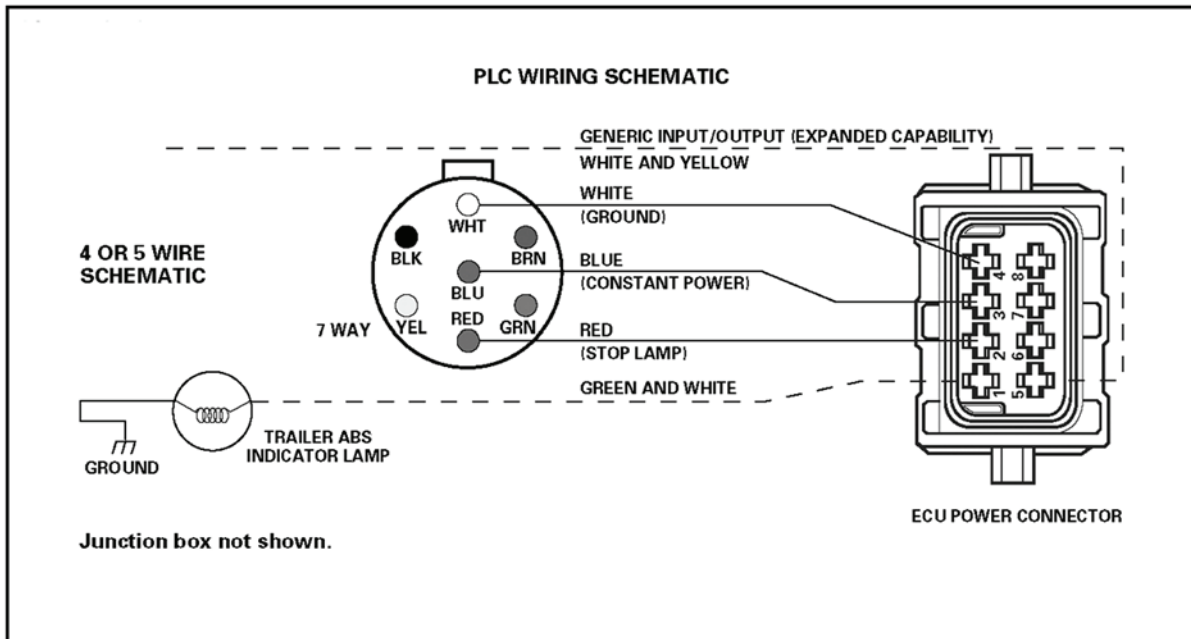

447-0147

Figure 2. Power Cable Wiring Diagrams.

WARNING

- To prevent serious eye injury, always wear safe eye protection when you perform vehicle maintenance or service.
- The ABS is an electrical system. When you work on the ABS, take the same precautions that you must take with any electrical system to avoid serious personal injury. As with any electrical system, the danger of electrical shock or sparks exists that can ignite flammable substances. You must always disconnect the battery ground cable before working on the electrical system.

NOTE

PLC signal is transmitted on the blue wire of the standard 12V-harness system.

BLINK CODE DIAGNOSTICS

1. The Meritor WABCO Enhanced Easy-Stop Trailer ABS ECU detects any electrical fault in the trailer ABS. Each of the faults has a code. When a fault occurs, the ECU stores the code for that fault in the memory.
2. There are two kinds of faults: active and stored. Active faults are those currently existing in the system, such as a broken wire. Stored faults are faults that have occurred but do not presently exist. Active faults can be cleared only after repairs are completed. Stored faults can be diagnosed with Pro-Link 9000.
3. The ECU signals a malfunction by lighting both the internal and external indicator lamp when a fault exists. The external ABS indicator lamp is usually mounted on the left rear of the trailer, near the rear wheels.
4. There are two ways to obtain blink codes:
 - a. Ignition Power Activation (recommended method)
 - b. Diagnostic Tool

NOTE

In previous versions of Easy-Stop, the blink code tool and the ABS indicator lamp would flash the blink code at the same time. With Enhanced Easy-Stop, this does not happen. The codes are displayed one blink at a time, first on the trailer ABS lamp, then on the blink code tool, as illustrated in Figure 3.

5. Although the ECU can store multiple faults in its memory, it only displays one blink code at a time. This is why it is important to recheck the blink codes after repairing a fault. If there are additional codes in the memory, they only blink after you have repaired the first fault.
6. Stored faults, clear all, and end of line test modes are available with Pro-Link 9000.

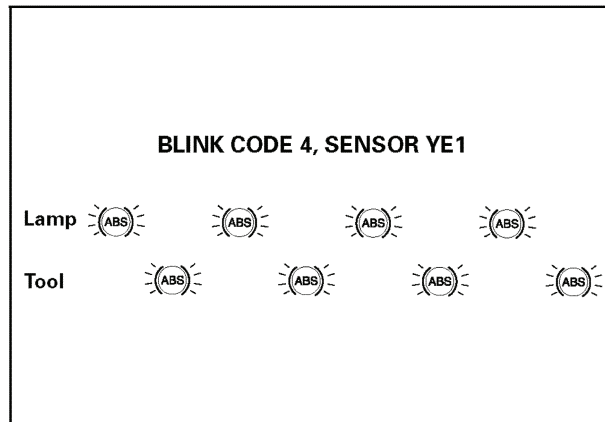

447-0156

Figure 3. Blink Code Diagnostics.

IGNITION POWER ACTIVATION

Ignition Power Activation is the process of using the vehicle's ignition switch (or interrupting the power on the blue wire by some other means) to display blink codes on the trailer ABS indicator lamp located on the side of the trailer. This method is for constant power vehicles only.

NOTE

For ignition power activation, power is provided by the ignition switch.

1. Turn the ignition switch on for no longer than 5 seconds. The ABS indicator lamp will be on.
2. Turn the ignition switch off. The ABS indicator lamp will go out.
3. Turn the ignition switch on. The ABS indicator lamp will then come on, then go out.
4. The blink code will be displayed three times by the ABS indicator lamp on the trailer.

Table 1. Blink Codes.

BLINK CODE	PROBLEM AREA	ACTION
3	Sensor BU1	Determine sensor location. Check sensor installation. Make necessary repairs.
4	Sensor YE1	Determine sensor location. Check sensor installation. Make necessary repairs.
5	Sensor BU2	Determine sensor location. Check sensor installation. Make necessary repairs.
6	Sensor YE2	Determine sensor location. Check sensor installation. Make necessary repairs.
7	External ABS modulator valve	Verify proper electrical installation. Check power supply. Make necessary corrections.
9	Internal modulator failure, inlet valve #2	Verify proper installation.
10	Internal modulator failure, inlet valve #1	Verify proper installation.
11	Internal modulator failure, outlet valve	Verify proper installation.
14	Power Supply	Verify proper electrical installation. Check power supply. Make necessary corrections.
15	ECU Failure	Verify proper installation.
16	SAE J1708 Failure	Internal failure, contact Meritor WABCO.
17	SAE J2497 (PLC) Failure	Internal failure, contact Meritor WABCO.
18	Generic I/O Failure	Verify proper electrical installation. Check power supply. Make necessary corrections.

END OF TASK

DIAGNOSTIC TOOL (BLINK CODE CHECK)**NOTE**

- The red dust cap on the diagnostic tool protects the tool during shipping. The tool and the LED are independently sealed against contamination.
- The SAE J1587 connector must be protected from contamination when the diagnostic tool is not installed. Reinstall the gray cap when the connector is not in use.
- Use the following procedures to install the diagnostic tool in the SAE J1587 connector.

1. Remove the gray protective cap from the J1587 connector.
 - a. Turn the cap counterclockwise.
 - b. Pull off the cap.
2. Align the notches on the tool with the notches on the connector.
3. Insert the tool firmly in the connector.
4. Firmly turn the gray ring of the tool clockwise to secure it in place (Figure 4).
5. After removing the diagnostic tool, replace the gray protective cap.

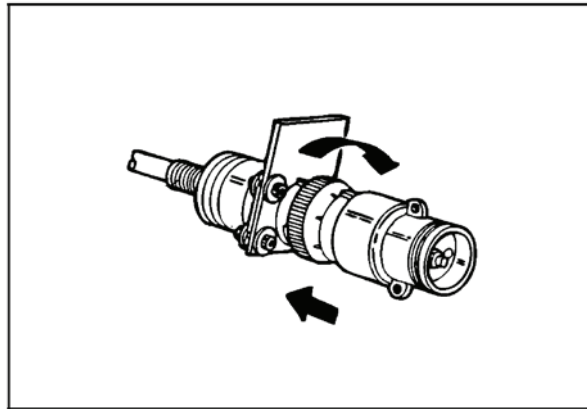

447-0157

Figure 4. Diagnostic Tool.

6. Make sure the vehicle is stationary:
 - a. Emergency brake ON.
 - b. Wheels properly chocked.
7. Provide 12V DC power (9.5 to 14V is acceptable range) to the ECU/Valve Assembly.
8. Check the ABS indicator lamp on the trailer.
 - a. If the indicator lamp comes ON briefly, then goes OFF, there is no fault in system.
 - b. If the indicator lamp comes ON and stays ON, there is an existing fault. Go to step 9.
9. Press the blink code switch once for one second and release the switch.
10. When there is an existing fault, the ABS indicator lamp will flash between three and eighteen times to identify the existing fault.
11. When there are existing faults, you must repair existing faults.
12. After you identify an existing fault, turn the power to the ECU OFF. Repair the fault. Turn the power to the ECU back ON.

DIAGNOSTIC TOOL (BLINK CODE CHECK) - CONTINUED

13. Repeat step 9. If there are no other existing faults in the system, the ABS indicator lamp will come ON, go OFF, and remain OFF.
14. If you have just repaired a sensor gap fault, the ECU is “waiting” to see a 4-mph signal on sensed wheels. Until this 4 mph is sensed by the ECU, the ABS indicator lamp on the trailer will remain ON.

END OF TASK**ECU/VALVE ASSEMBLY****WARNING**

Release all pressure from the air system before you disconnect any components. Pressurized air can cause serious personal injury.

Removal

1. Release all pressure from the air system.
2. Attach labels to identify all air lines.
3. Disconnect the air lines from the ECU/Valve Assembly.
4. Disconnect the power (or power/diagnostic) cable, additional relay valve cable (if used), and all sensor cables from the ECU/Valve Assembly (Figure 5).
5. Remove the ECU/Valve Assembly from its mounting location:
 - a. Bracket-Mounted: Loosen and remove the two mounting bolts and lock nuts that hold the assembly to the cross member. Remove the assembly.
 - b. Nipple-Mounted to Air Tank: Unscrew the assembly from the air tank.

NOTE

- The ECU/Valve Assembly is supplied with black protective caps on each sensor connector.
- When a sensor cable is not plugged into a sensor connector, the black cap must remain on the connector to protect it from dirt and contamination (Figure 5).

ECU/VALVE ASSEMBLY - CONTINUED

6. If the assembly being replaced is under warranty, please return it to the trailer OEM for replacement.

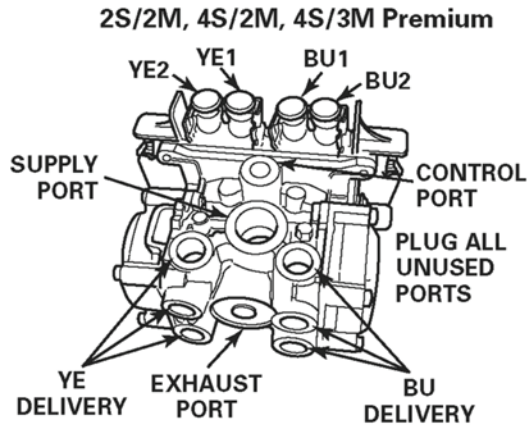
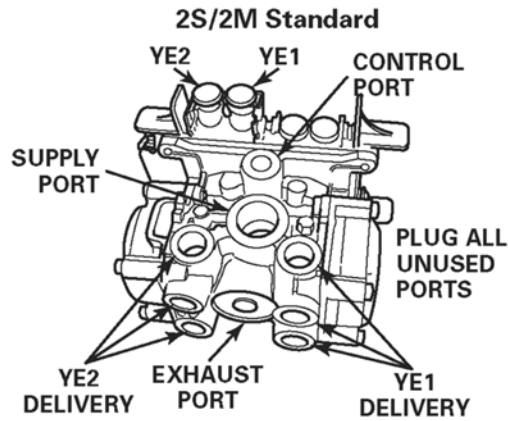
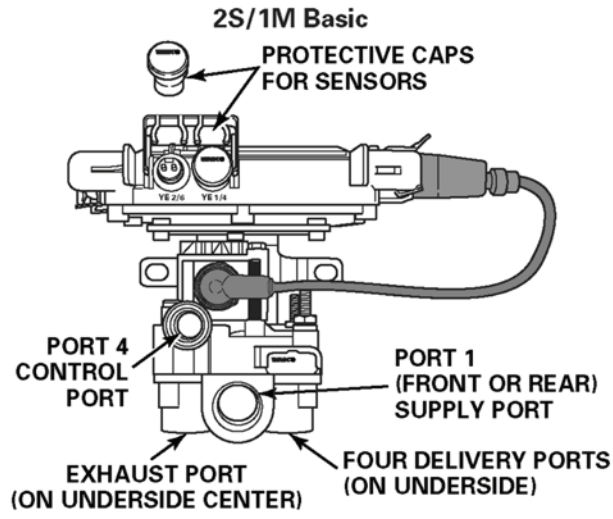

447-0244

Figure 5. ECU/Valve Assembly.

ECU/VALVE ASSEMBLY - CONTINUED1. **Tank-Mounted.****WARNING**

You must use a Schedule 80 hex nipple (3/4 in. NPTF) to mount the ECU/single modulator valve assembly securely to the air tank to avoid possible serious personal injury and damage to the component.

- a. Use a 3/4 in. Schedule 80 hex nipple to attach ECU/single modulator valve assembly to a reinforced air tank. Do not overtighten.

CAUTION

Meritor WABCO does not recommend use of a vise when installing the hex nipple. Use of a vise may cause over-clamping. Over-clamping may damage the internal components of the ECU/single modulator valve assembly.

- b. Use a 3/4 in. pipe plug to plug unused supply port (Port 1). Apply SAE-standard, DOT-approved Teflon tape or paste-type thread sealant to all pipe threads beyond the first two threads. Pipes with pre-applied thread sealant may also be used.
- c. Rotate and tighten the ECU/single modulator valve assembly until the exhaust port faces down and the connection is secure. Use a torque wrench or ratchet with extension at the 3/4 in. pipe plug installed on the front supply port (Port 1) (Figure 6).

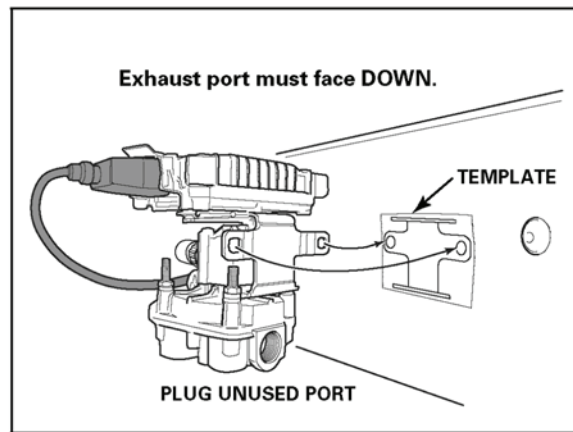

Figure 6. Tank-Mounted Valve.

2. **Bracket-Mounted to Crossmember of Vehicle (2S/1M Basic).**

- a. Install a 3/4 in. NPTF fitting in supply port (Port 1). Use a 3/4 in. pipe plug to plug unused supply port (Port 1). Apply SAE-standard, DOT-approved Teflon tape or paste-type thread sealant to all pipe threads beyond the first two threads. Pipes with pre-applied thread sealant may also be used.
- b. Attach mounting bracket to vehicle crossmember midway between the side rails, close to the brake chambers the valve serves.
- c. Use two 3/8 in. Grade 8 bolts with prevailing torque nuts and washers to attach assembly to the vehicle crossmember. Tighten bolts to 18 lb-ft (24 Nm).

END OF TASK

END OF WORK PACKAGE

FIELD AND SUSTAINMENT MAINTENANCE
BRAKE DRUM RE-BORE LIMITS AND/OR MAXIMUM WEAR DIAMETER

ADDITIONAL INFORMATION

1. This information is furnished to advise the importance of the re-bore limits and/or maximum wear diameter as shown on our Webb brake drums. This dimension is cast on brake drum as indicated in Figure 1. The dimension is the maximum safe diameter to which a drum may be turned, ground, and/or worn.
2. To ensure product safety, it is critical that any brake drum reaching this dimension by turning, grinding, and/or wearing be considered unsafe and immediately replaced. Any brake drum exceeding this dimension is considered a safety hazard, and is not subject to warranty consideration.

NOTE

Dimensions are in inches.

3. The dimension shown on brake drums is the current maximum diameter and supersedes any previously published information.
4. Most Webb brake drums allow a maximum diameter of 0.120 over the nominal new diameter. This allows 0.080 for re-boring and an additional 0.040 for wear.

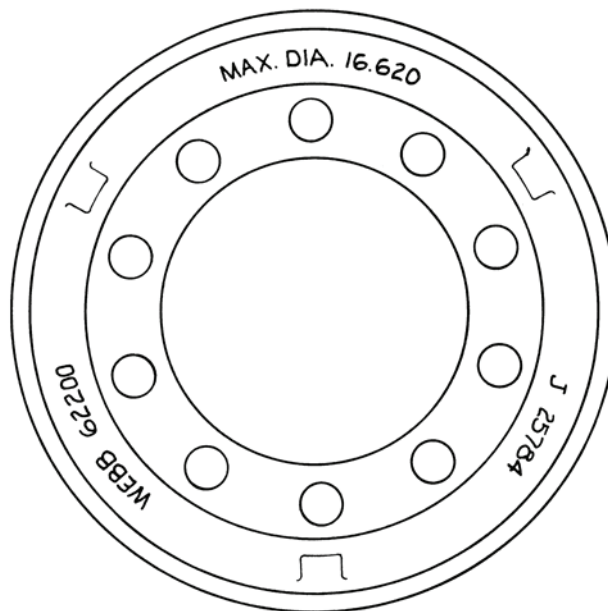

447-0130

Figure 1. Brake Drum Dimensions.

BRAKE DRUM DATA SHEET

When selecting a Webb replacement drum, the manufacturer's name and part number is helpful. If this information is not available, a replacement drum can be selected by comparing dimensions. A drawing is shown below, which indicates the dimensions required to determine the existence of a replacement drum. If all of the dimensions shown are not available, you must provide at least dimensions C, D, E, J, K, and O (Figure 2) to make a selection.

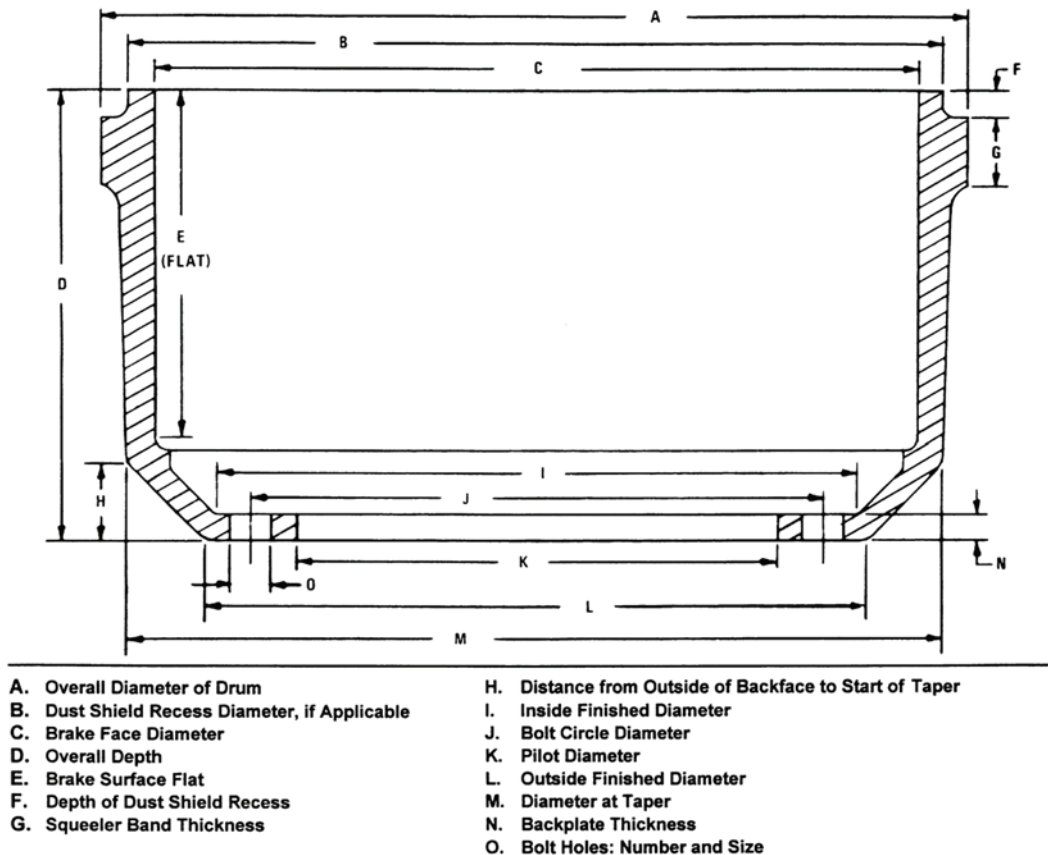

447-0131

Figure 2. Dimensions Required for a Replacement Drum.

BRAKE DRUM SERVICE INFORMATION

To achieve maximum life and optimum performance, proper brake maintenance and brake balance are essential. The following procedures are suggested as a means of obtaining maximum service and to determine the need for replacement.

Inspection of Brake Drums

1. When relining brakes, the brake drum should be cleaned and inspected. To be suitable for further service, the brake drum should pass the following checks:
 - a. The brake surface should be free of scoring, excessive heat checks, and cracks.
 - b. The brake surface diameter should be within the maximum diameter cast or stamped on the drum.
 - c. The mounting holes and pilot must be round and true.
 - d. The mounting surface must be clean and flat.
2. If any of the above conditions are not met, the brake drum should be replaced.

BRAKE DRUM SERVICE INFORMATION - CONTINUED**Turning the Brake Surface**

It may be desirable to turn or resurface the braking surface to remove small heat checks or other surface defects. The following should be noted when turning:

- a. When resurfacing a drum, allow at least 0.040 in. under the maximum diameter for additional wear. This usually means the drum may be turned a total of 0.080 in. over the brake surface diameter of a new brake drum.

Example:	New drum diameter	16.500
	Re-bore allowance	00.080
	Diameter after re-bore limit is reached	16.580
	Wear allowance	0.040
	Maximum diameter	16.620

CAUTION

Do not turn or wear a brake drum beyond the maximum diameter stamped or cast on the brake drum.

- b. The maximum diameter or discard diameter is the maximum diameter to which the brake drum may be turned or worn and still be unusable. If any portion of the brake surface exceeds the maximum diameter it must be discarded. The maximum diameter is 0.120 in. over the nominal new diameter unless stated otherwise stated on the casting. The maximum diameter cast into the back plate portions of the brake drum supersedes all published information.

Determining Replacement

1. Replacement of the brake drum is required if any of the following conditions exist:
 - a. Brake drum is cracked.
 - b. The brake surface is heat checked, grooved, or worn beyond the re-bore limit of 0.080 in., or maximum diameter.
 - c. The back plate is cracked.
 - d. The bolt holes are elongated.
 - e. Brake drum is known to have been severely overheated.
 - f. Brake drum is out-of-round.
2. When selecting a Webb replacement drum, the manufacturer's name and part number are helpful. If this information is not available, a replacement drum can be selected by comparing dimensions. Figure 2 shows the dimensions required to determine the existence of a replacement drum. If all the dimensions shown are not available, you must provide at least the following dimensions from the previous page to make a selection:
 - a. Brake Face Diameter
 - b. Overall Depth of Drum
 - c. Brake Surface Flat
 - d. Bolt Circle Diameter
 - e. Pilot Diameter
 - f. Bolt Holes: Number and Size

REPLACEMENT PROCEDURES**NOTE**

Cleanliness is most important. After removing the brake drum to be replaced, make sure all mounting surfaces on the spoke wheel or hub are clean. All foreign material should be removed to ensure proper attachment of the brake drum.

1. Assemble the brake drum to the hub.

NOTE

Hubs using an outboard mount drum do not have to be removed from the axle to facilitate brake drum replacement. It is suggested, however, that the torque on the spindle nut be checked to make sure it is correct.

2. Make sure the brakes are fully released and adjusters are fully backed off.
3. Place the assembly on the axle and adjust the bearings.
4. Inspect the lining location on the brake surface.
5. Adjust the brakes.

NOTE

All adjustments should be made when brake drums are cold with brakes fully released.

- a. Standard Slack Adjusters. Raise the axle until the wheel can be turned freely. If the slack adjuster has a positive lock mechanism, depress the locking sleeve to disengage it. Turn the adjusting screw until the brakes begin to drag, and then back off the adjustment so that the wheel turns freely. When adjustment is completed, the adjusting screw nut should be positioned so the locking sleeve engages the adjusting nut screw. In the case of the ball indent type, the ball should engage the indent on the plunger shaft.
- b. Automatic Slack Adjusters. Require initial manual adjustment. Consult the manufacturer's literature adjustment procedure.

END OF TASK**END OF WORK PACKAGE**

FIELD AND SUSTAINMENT MAINTENANCE
SERVICE BRAKES S-CAMSHAFTS AND SHOES

SINGLE AXLE

1. Always reline both wheels of a single axle at the same time.
2. Always install the same linings and drums on both wheels of a single axle.

TANDEM AXLE

1. Always reline all four wheels of a tandem axle at the same time.
2. Always install the same linings and drums on all four wheels of a tandem axle.

PRIMARY SHOE LOCATIONS**NOTE**

The first shoe past the cam in the direction of wheel rotation is the primary shoe. Refer to Figure 1 to determine primary and secondary shoe locations.

1. The primary shoe can be either at the TOP or the BOTTOM position, depending on the location of the cam.
2. If the cam is BEHIND the axle, the TOP shoe is the primary shoe.
3. If the cam is in FRONT of the axle, the BOTTOM shoe is the primary shoe.

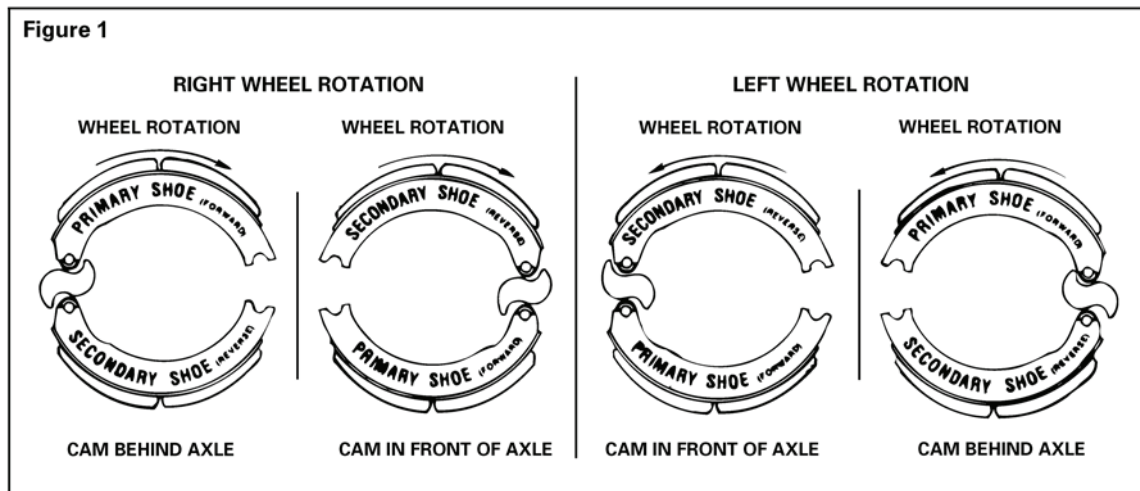

447-0158

Figure 1. Primary and Secondary Shoe Locations.

END OF WORK PACKAGE

FIELD AND SUSTAINMENT MAINTENANCE

PRO-TORQ SPINDLE NUT

PRO-TORQ® INSTALLATION PROCEDURE AND WHEEL BEARING ADJUSTMENT FOR THE M871R TRAILER APPLICATION (STEMCO P/N 447-4743)

NOTE

The Pro-Torq spindle nut is composed of two parts, the nut and a steel spring keeper, which is painted orange on the side that must be facing out.

STEP 1.

Remove the Keeper from the Nut:

A, B, C

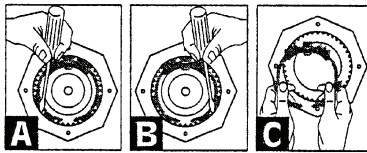

Use a screwdriver to carefully pry the keeper arm from the undercut groove on each side until the keeper is released.

STEP 2.

Seat The Bearing:

With hub or hub/drum only:
Using a torque wrench:

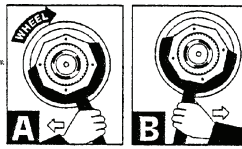

- A (1) Tighten the nut to 200 ft-lbs. Spin the wheel at least one full rotation.
- (2) Tighten the nut to 200 ft-lbs. Spin the wheel at least one full rotation.
- (3) Tighten the nut to 200 ft-lbs.
- B Back the nut off until it is loose.

TOOLS REQUIRED FOR INSTALLATION			
Part Number	(3/4" Drive) Socket Req'd	Owatonna Co. Ref. Part No.	Euclid Int'l Ref. Part No.
Trailer Axle Nut 447-4743 (262516C)	3 3/4" 8 point	1925	E-1925

Note: Ford application 12,000 lbs SIFCO Steer Axle requires OEM inner washer to be installed prior to installation of PRO-TORQ® nut system.

STEP 3.

Adjust The Bearing:

- A Use a torque wrench to torque the nut to the specifications while rotating the wheel.
- B Back the nut off one raised face mark (according to chart).

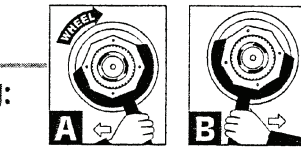

Part Numbers	Adjusting Torque	Backoff
Trailer Axle Nut 447-4743 (262516C)	100 ft-lbs	1/4 turn

WARNING

Failure to follow this instruction could cause the wheel to come off and cause bodily injury. Failure to back off the nut will cause the bearing to run hot and be damaged.

STEP 4.

Install the Keeper:

ORANGE SIDE FACING OUT

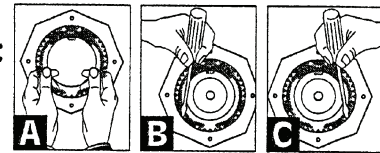

- A Insert the keeper tab into the undercut groove of the nut and engage the keyway tang in the axle keyway. Insert keeper tab with bent legs facing out.
- B Engage the mating teeth.
- C Compress and insert the keeper arms, one at a time, into the undercut groove with a screwdriver.

WARNING

Failure to follow this instruction could cause the wheel to come off and cause bodily injury. Do not bend or manipulate keyway tang in any way. Doing so may cause the tang to break off in service.

STEP 5.

Inspect the Installation:

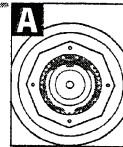

- A Failure to follow this instruction could cause the wheel to come off and cause bodily injury. Make sure that the keeper tab and keeper arms are fully seated into the undercut groove. Inspect keyway tang to insure it does not contact the bottom of the keyway. If contact exists, immediately notify your PRO-TORQ® representative.

THIS PROCEDURE WILL CONSISTENTLY PRODUCE A BEARING SETTING OF .001" TO .003" END PLAY.

WARNING

Failure to follow this instruction could cause the wheel to come off and cause bodily injury. The PRO-TORQ® Spindle Nut is sold as an assembly with the keeper in place. DO NOT attempt to place the nut on the spindle or tighten or loosen the nut on the spindle while the keeper is locked inside the nut. Doing so may deform the keeper and allow the nut to unthread during operation.

447-0159

Figure 1. Pro-Torq Spindle Nut.

END OF TASK

REMOVAL**WARNING**

A new orange keeper arm must be replaced if it is damaged when removed or installed in the nut. It is recommended to replace the keeper arm each time it is removed. The original nut may be reused; the original keeper may be reused if not damaged. Failure to comply this warning may cause injury or death to personnel and damage to the equipment due to wheel-end loss.

CAUTION

Failure to remove the orange keeper before removing the nut will result in damaged threads to both the nut and the axle end spindle. Over-torque of the nut will result in stripped threads.

Use a small blade screwdriver to carefully pry each keeper arm from the undercut groove in the nut and release the orange keeper from the nut. The arms are on opposite sides of the open end of the keeper.

END OF TASK**INSTALLATION****CAUTION**

- Keeper orange side must be facing out.
 - Only a small bladed screwdriver is required to move/install the orange keeper.
 - The orange keeper square tang must not bottom in the spindle square keyway.
 - No other washers or lock rings are required for this installation.
 - Orange keeper teeth must fully engage nut teeth.
1. Thread the nut, without keeper arm, onto the axle spindle threaded end, keeper side facing out. Hand tighten nut against outer bearing.
 2. While slowly rotating the wheel/hub, use a torque wrench and socket to torque the nut to 200 lb-ft (271 Nm). Wheel/hub must be rotated slowly while torque is applied. This action will seat the inner and outer bearings.
 3. Using the torque wrench and socket, back off the nut until it is hand tight.
 4. While slowly rotating the wheel/hub, using the torque wrench and socket, re-torque the nut to 100 lb-ft (136 Nm). Wheel/hub must be rotated slowly when torque is applied. This action will apply the final seat to the inner and outer bearings.

NOTE

After 1/4 back-off, nut should be movable by hand.

5. Back nut off 1/4 turn. Refer to the chart in Step 3 of the previous page.
6. Install the keeper, orange side facing out, by inserting the keeper square outer tab into the undercut groove on the nut aligned with the square cut keyway groove on the spindle. Rotate the keeper into position so that the inner keeper tang tilts into the square spindle keyway. The teeth on the keeper will engage the teeth on the nut. Do not force the keeper into position. Force will damage the keeper. Use only a small bladed screwdriver for installation of the keeper.
7. If the square inner tang does not line up with the spindle square keyway, back the nut off very slightly until it does (no more than one tooth). This back-off will engage the keeper and nut teeth if this did not happen in step 6. Using a small bladed screwdriver carefully compress and insert the keeper arms, one at a time, into the undercut groove in the nut. Again, the orange side of the keeper **MUST** be facing out.

INSTALLATION - CONTINUED

8. Inspect the installation to make sure that the keeper outer tab and the keeper arms are fully seated into the undercut groove in the nut. Use the small bladed screwdriver to gently flex the keeper arms to ensure they fully engage the groove in the nut. Visually inspect the seating and that the teeth are fully engaged in the nut teeth.
9. Inspect the square keeper tang to make sure it does not contact the bottom of the square groove on the axle spindle.
10. Check the bearing setting by using a dial indicator to verify the bearing end play. The nut will produce a consistent setting of 0.001 to 0.003 in. (0.025 to 0.076 mm) end play.

END OF TASK**END OF WORK PACKAGE**

FIELD AND SUSTAINMENT MAINTENANCE
HUBODOMETER®
Installation Instructions, General Information, Care of HUBODOMETER®

INSTALLATION INSTRUCTIONS

1. Mount HUBODOMETER® to face of hubcap or bracket.
2. Use washer under locknut.
3. Use 15 lb-ft (20.3 Nm) of torque to tighten locknut. **DO NOT USE AIR IMPACT WRENCH. DO NOT EXCEED 15 lb-ft (20.3 Nm) OF TORQUE.**
4. If necessary, use strap wrench to hold HUBODOMETER® while tightening.
5. **DO NOT USE PAINTS, SOLVENTS, OR THINNERS ON THE HUBODOMETER® FACE, GRILAMID HUBCAP, OR HUBODOMETER® HUBCAP WINDOW.**
6. The recommended torque for the 3/8 in. pipe plug for aluminum hubcaps is 9 lb-ft (12.2 Nm). A suitable sealant may be used on the pipe plug threads if desired. On Grilamid hubcaps with plastic fill plug and O-ring, tighten to a torque not to exceed 10 lb-ft (13.6 Nm).
7. The proper oil level for the STEMCO HUBODOMETER® window is indicated by the inside protruding ledge of the window (Figure 1).

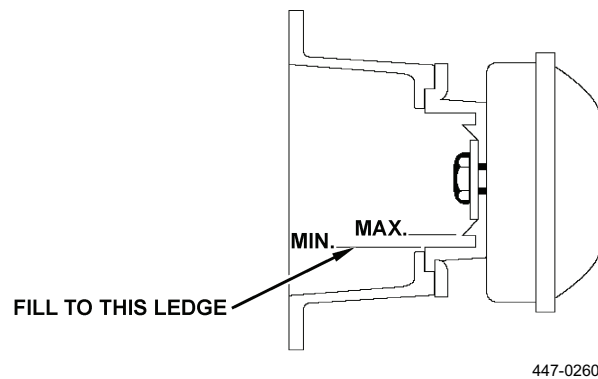

Figure 1. HUBODOMETER®.

END OF TASK
GENERAL INFORMATION
HUBODOMETER®

1. Basically a driveless, mechanical-meter, hub-mounted odometer. The name HUBODOMETER® is actually a registered trademark name for a specific STEMCO product.
2. The accuracy of the HUBODOMETER® is plus or minus 2 percent.
3. It is specifically calibrated to a tire size, make and model, and to the mid-life of the tire tread, not the depth of new tire treads.

GENERAL INFORMATION - CONTINUED

4. To preclude the mechanically curious from opening the HUBODOMETER® case to find out how it works, the following information regarding its contents is provided:
 - a. An independent main shaft to protect it from front (face) damage.
 - b. A spring-loaded counterweight to reduce spin.
 - c. A brass-on-steel worm gear.
 - d. An externally pinioned odometer mechanism using low-friction molded components.
 - e. The case is hermetically sealed to prevent moisture from getting in.
5. The HUBODOMETER® works basically the same as the odometer in a car except that it is not driven or electrical. It is an independent mechanical device.
6. There are three basic ways to mount the HUBODOMETER®.
 - a. As a single component hubcap with the HUBODOMETER®.
 - b. As a mount on to a hubcap.
 - c. On a universal mounting bracket that is bolted to the hubcap.
7. It may be used either “wet” (oil) hubs or “dry” (grease) hubs.

Installation

What if you have to replace a HUBODOMETER®?

- a. If a new HUBODOMETER® is installed, will it read zero miles, and will the original mileage from the old HUBODOMETER® be lost?
- b. Yes, but there is a way to preclude this problem. When ordering the new HUBODOMETER® from the manufacturer, request that the mileage be PRE-SET to the mileage registered on the old HUBODOMETER®. There is normally a nominal fee for this but it is well worth the cost in order to keep a running record of mileage and service intervals, with no updates or confusion.

END OF TASK**CARE OF HUBODOMETER®****CAUTION**

- Do not stand on, kick, or rest things like booths and wheels on HUBODOMETER®. It will survive all those on off-road ventures but excessive personal involvement may shorten its life.
- Do not use solvents, thinners, or paints on the HUBODOMETER® face. If reflective glare is a problem, tape over the face except for the odometer reading so you can check the mileage as needed.
- Do not use air or electrical tools when removing or installing it. Use only hand tools. If it slips when you loosen or tighten the meter lock nut, put a strap wrench around the meter to hold it.
- Normally only 15 lb-ft (20.3 Nm) of torque (max) are required to secure the locknut - no more.

The HUBODOMETER® will keep accurate track of the mileage on your semitrailer and offer a way to identify when service is required and document service intervals. It does not need much in the way of service, but it does need to be somewhat protected against damage.

END OF TASK**END OF WORK PACKAGE**

FIELD AND SUSTAINMENT MAINTENANCE

AUTOMATIC SLACK ADJUSTERS

Installation, Adjustment, How to Measure Push Rod Stroke, Brake Recline/Checking Procedure, Brakes Troubleshooting

INSTALLATION

WARNING

Make sure the wheels are chocked before servicing the semitrailer. Release the parking brake and check that the push rod is fully released. If the push rod is not fully released, the ASA cannot be installed properly. Semitrailer movement may cause injury or death to personnel and damage to the equipment.

NOTE

- Chock wheels to prevent semitrailer from moving. Check that the push rod on the air brake chamber is FULLY RETRACTED. Apply air pressure to release spring brake.
 - If air pressure is not available, spring brake must be completely caged back. Install anchor bracket but do not tighten air brake chamber nut; leave loose.
 - Block wheels to prevent vehicle from rolling. Ensure system tank pressure is above 100 psi (689 kPa).
 - Both OEM ASA (P/N 409-10683) and the new ASA (P/N 409-20002) can be identified by their part number stamped on the control arm housing. Also, the new ASA does not have a pointer (installation indicator) that has to fall within a slot of proper installation.
1. Check that the push rod is fully retracted; apply air to release spring brake. If air is not available, spring brake must be manually caged back.
 2. Install anchor bracket loosely.
 3. Some strap brackets have two mounting holes. Proper mounting location is determined by the length of adjuster arm: 5 in. and 5-1/2 in. adjuster arm lengths utilize the shorter hole location, while 6 in. and 6-1/2 in. length adjusters utilize the longer hole locations.
 4. Do not tighten anchor bracket fasteners at this time.
 5. Apply antiseize type lubricant to camshaft splines.

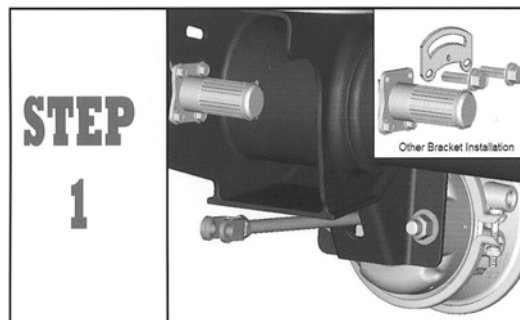

447-0165

Figure 1. Installation.

INSTALLATION - CONTINUED

6. Install the slack adjuster onto the camshaft with the adjusting hex pointing away from the brake chamber.
7. Secure the slack adjuster on the camshaft. Use at least one inner washer and enough outer washers to allow no more than .060 in. movement of adjuster on camshaft.

NOTE

DO NOT pull push rod out to meet the brake adjuster.

8. Rotate the 7/16 in. adjusting hex nut clockwise until the clevis hole lines up with the brake adjuster arm hole.

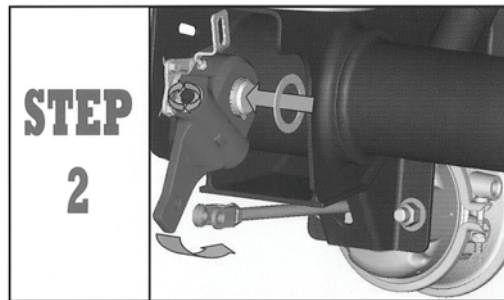

447-0166

Figure 2. Installation.

9. Apply antiseize to clevis pin, install, and secure with cotter pin.
10. The S-ABA control arm can be placed anywhere within the range of the bracket slot for automatic adjustment to take place. Haldex recommends, however, rotating all control arms towards the axle until they come to a complete stop and securing in that position. This will create a “common” position for all wheels.
11. Tighten all anchor bracket fasteners.

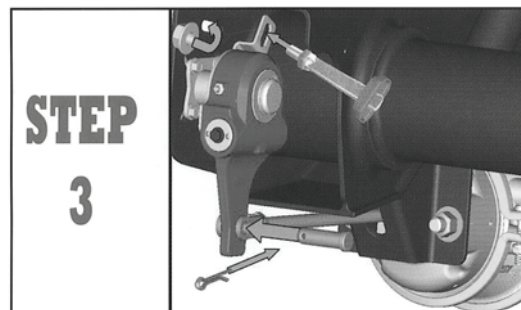

447-0167

Figure 3. Installation.**END OF TASK**

ADJUSTMENT

1. The adjuster must be manually adjusted at this time.
2. Rotate the adjusting hex clockwise until the lining lightly contacts the drum.
3. Back-off the adjuster by turning the adjusting hex counterclockwise 1/2 of a turn (Figure 4).
4. A minimum of 13 lb-ft is necessary to overcome the internal clutch. A ratcheting sound will be present.

WARNING

DO NOT use an impact wrench or permanent internal damage will occur!

NOTE

To ensure proper fit and function, always replace both adjuster and mounting bracket, as a set.

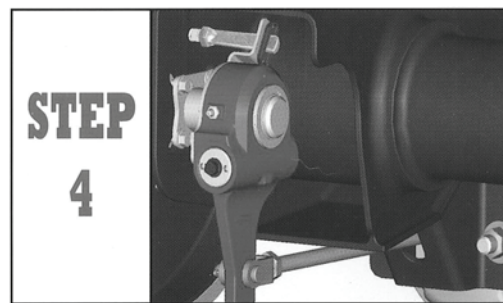

447-0168

Figure 4. Adjustment.

END OF TASK**HOW TO MEASURE PUSH ROD STROKE****NOTE**

The maximum effective push rod stroke, as recommended by the air brake chamber manufacturer, must be less than 2.5 in. (6.4 cm).

1. With a tape measure, measure the movement of the push rod from the completely released position to the applied position 90 to 100 psi (621 to 690 kPa).
2. This movement can also be measured by:
 - a. Putting a mark on the push rod where it exits the air brake chamber (BRAKE RELEASED).
 - b. Applying the brake.
 - c. Measuring the movement of the mark to the face of the air brake chamber housing.

END OF TASK

BRAKE RELINE/CHECKING PROCEDURE

1. Rotate the adjustment hex counterclockwise approximately 1/2 turn to create excessive brake lining to drum clearance.
2. Apply the brakes.
3. On release of brakes, observe the adjustment hex rotation. This rotation indicates the ASA is making an adjustment and is working properly.

NOTE

Placing a 7/16 in. (11 mm) box end wrench on the hex adjustment will make the movement easier to see.

4. On each subsequent brake release, the amount of adjustment and push rod stroke will be reduced until proper clearance is achieved.
5. During brake reline, check the de-adjustment torque. Place a 7/16 in. (11 mm) torque wrench on the adjustment hex. Turn the hex counterclockwise and check that the clutch does not slip at a torque LESS than 13 lb-ft (17.6 Nm). A ratcheting sound should occur. If the clutch slips at a lesser torque (less than 13 lb-ft [17.6 Nm]), the ASA must be replaced.

END OF TASK**BRAKE TROUBLESHOOTING****NOTE**

- The ASA is NOT a cure-all for foundation brake deficiencies.
- If the proper push rod stroke cannot be maintained, be sure to thoroughly check the other brake components.
- This check could also avoid unnecessary ASA replacement.

1. Check the foundation brake for:
 - a. Worn camshaft and bushings
 - b. Broken shoe return springs
 - c. Air chambers not releasing
 - d. Worn or broken brake components
 - e. Loose wheel bearings
2. Check the ASA for:
 - a. Proper push rod stroke
 - b. Proper ASA installation
 - c. Loose, broken, or bent adjuster brackets
 - d. Worn clutch assembly
 - e. Adjuster not fully releasing

END OF TASK**END OF WORK PACKAGE**

FIELD AND SUSTAINMENT MAINTENANCE

AXLE ALIGNMENT

After the suspension has been installed under the trailer, the axles should be properly aligned in relation to the trailer kingpin in the following manner:

- Measure the distance from kingpin to centerline of spindles on front axle. Dimensions A and B must be equal within 1/8 in. (Figure 1).
- After aligning the front axle, tighten U-bolts and end clamp bolts to specification on that axle only.
- Next, align rear axle with front axle. Dimensions C and D must be equal within 1/16 in. (Figure 1).
- After aligning rear axle with front axle, tighten U-bolts and end clamp bolts on rear axle.

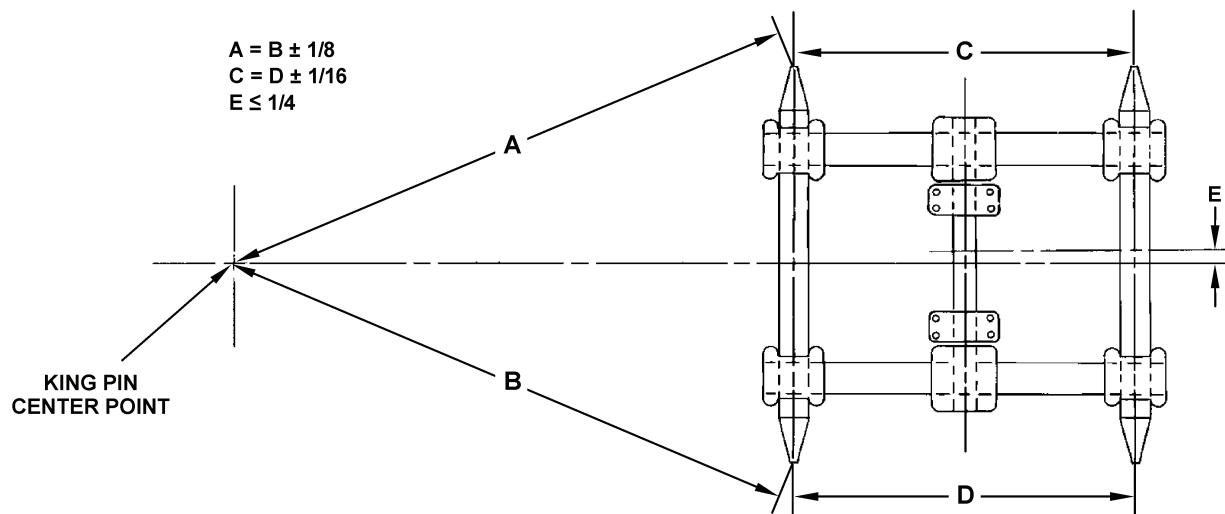

447-0254

Figure 1.

Axle Alignment.

- Check dimension E, the lateral centerline relationship of trailer body and axles.
- Dimension E must not exceed 1/4 in. At this time, recheck alignment of front axle with kingpin, and rear axle with front axle.
- After alignment has been accomplished, tighten U-bolts and nuts to specification.

END OF TASK**END OF WORK PACKAGE**

FIELD AND SUSTAINMENT MAINTENANCE**AXLE IDENTIFICATION**

AXLE IDENTIFICATION

All of the information necessary to identify a particular trailer axle is located on the trailer axle identification tag. Located at the center of the axle beam, this ID tag is stamped with the axle model number, serial number, and date of manufacture.

1. The model number is composed of letters and digits (e.g., TN-4670-Q-2020). This number is used to identify the axle assembly when ordering replacement parts.
2. The serial number is composed of letters and digits (e.g., KNA-38050685). This number can be used to identify a particular trailer axle, and the material and components used to build the axle.
3. The date of manufacture is indicated by a Julian date (e.g., 27693). The first three digits (276) indicate the 276th day of the year, or October 3rd. The last two digits (93) indicate the year, or 1993.

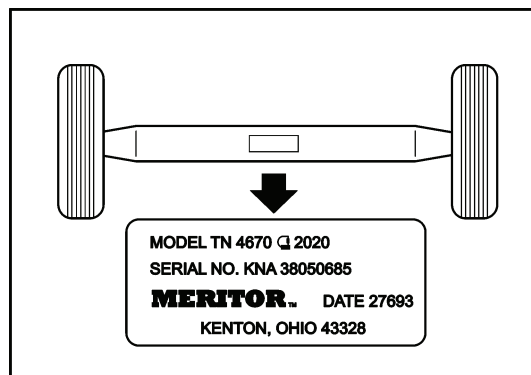

447-0239

Figure 1. Axle Identification.

MODEL NUMBERS

Model numbers for Meritor trailer axles are composed of letters and digits (e.g., TQD 4670 Q 52). These letters and digits indicate the weight capacity and type of components installed on the axle.

Meritor aftermarket model numbers differ from the current production model numbers detailed below.

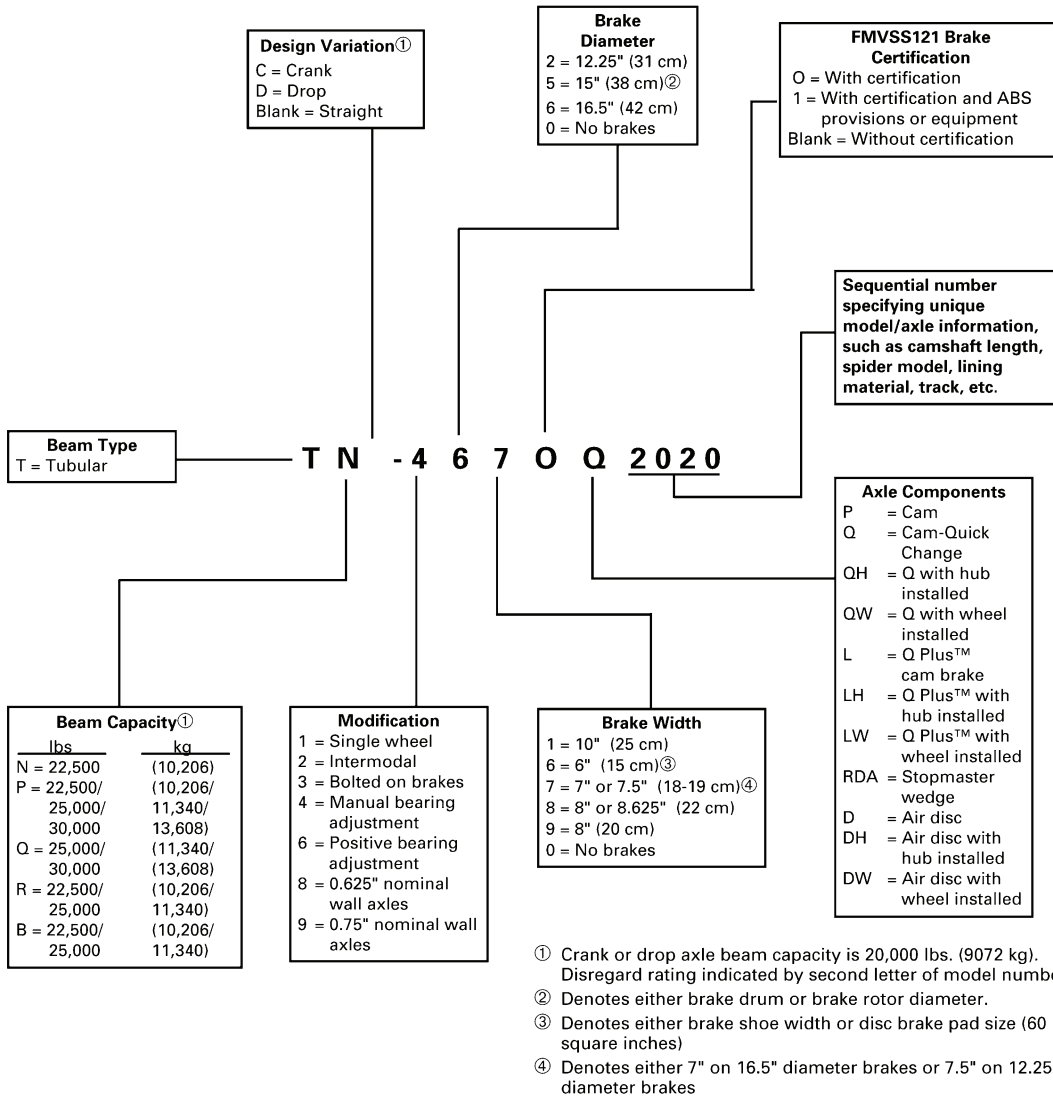

Figure 2. Current Production Model Numbers.

447-0240

END OF WORK PACKAGE

INDEX

Subject **WP Sequence No.-Page No.**

Numerics

10 Tire Tips WP 0094-1
 10/20 Inspection Checklist WP 0086-1

A

Abbreviations/Acronyms, List of WP 0001-3
 ABS
 Brake Power Connections Replacement WP 0036-1
 Warning Light Replacement WP 0062-1
 Additional Authorization List (AAL) WP 0084-1
 Air
 Brake Chamber Control Valve Replacement WP 0040-1
 Brake Chambers Replacement WP 0038-1
 Lines and Fittings Replacement WP 0037-1
 Reservoir Service WP 0018-1
 Reservoirs Replacement WP 0039-1
 Antisail Mud Flaps Replacement WP 0054-1
 Automatic Slack Adjusters
 Adjustment WP 0110-3
 Brake Recline/Checking Pressure WP 0110-4
 How to Measure Push Rod Stroke WP 0110-3
 Installation WP 0110-1
 Maintenance WP 0034-1
 Axle
 Alignment WP 0111-1
 Identification WP 0112-1

B

Basic Issue Items (BII) WP 0083-1
 Bearing
 Installation WP 0104-3
 Removal WP 0104-1
 Blackout Lights Replacement WP 0025-1
 Box Replacement
 Manifest WP 0058-1
 Stowage WP 0057-1
 Stowage Side Panels WP 0070-1
 Brake Drum
 Maximum Wear Diameter WP 0106-1
 Re-Bore Limits WP 0106-1
 Bulkhead Replacement WP 0052-1

C

Cleaning Instructions WP 0023-2
 Clearance Lights Replacement WP 0026-1
 Conspicuity Tape Replacement WP 0064-1
 Converting Fractions to Decimals WP 0087-1
 Corner Replacement WP 0053-1

INDEX - CONTINUED

Subject **WP Sequence No.-Page No.**

C - Continued

Corrosion	
Prevention and Control (CPC)	WP 0001-1
Protection	WP 0023-4
Coupling Instructions	WP 0092-1

D

Data Plates Replacement	WP 0061-1
Decals Replacement	WP 0061-1
Description and Use of Operator Controls and Indicators	
Air Lines and Electrical Cables Connections	WP 0004-4
Ground Boards	WP 0004-3
Ladder	WP 0004-5
Landing Legs	WP 0004-2
Destruction of Army Materiel to Prevent Enemy Use	WP 0001-1
Direct Support Maintenance Instructions	WP 0069-1
Dock Bumpers Replacement	
M871A2	WP 0044-1
M871R and M871A1R	WP 0043-1

E

ECU Valve Replacement	WP 0035-1
Electrical	
Connectors Cleaning	WP 0017-1
Schematic	WP 0023-6
Enhanced Easy-Stop Trailer ABS with PLC	WP 0105-1
Equipment	
Characteristics, Capabilities, and Features	WP 0002-1
Data	
M871A2R	WP 0002-7
M871R and M871A1R	WP 0002-6
M871R, M871A1R, M871A2R	WP 0002-8
Improvement Recommendations (EIRs), Reporting	WP 0001-1
Expendable and Durable Items List	WP 0085-1
Extreme Cold, Operation Under Unusual Conditions	WP 0006-1
Extreme Heat, Operation Under Unusual Conditions	WP 0006-1

F

Fastener Size	WP 0088-1
Fifth Wheel Connections	WP 0091-1
Floor Deck Boards Replacement	
M871A2R	WP 0056-1
M871R and M871A1R	WP 0055-1
Fording, Operation Under Unusual Conditions	WP 0006-2
Frame Repair	WP 0073-1

G

General	
Information	WP 0001-1
Maintenance Instructions	WP 0023-1

INDEX - CONTINUED

Subject **WP Sequence No.-Page No.**

G - Continued

Support Maintenance Instructions	WP 0069-1
Gladhands	
Cleaning	WP 0019-1
Replacement	
M871A1R and M871A2R	WP 0042-1
M871R	WP 0041-1
Ground Boards Replacement	WP 0051-1

H

Hub Piloted Disc Wheels	WP 0097-1
HUBODOMETER®	
Care of	WP 0109-1
Installation Instructions	WP 0109-1
Replacement	WP 0063-1
Hubs and Drums Replacement	WP 0033-1

I

Inspections Instructions	WP 0023-3
--------------------------------	-----------

K

Kingpin	
Maintenance Recommendations	WP 0090-1
Replacement	WP 0090-1
M871A2R	WP 0075-1
M871R and M871A1R	WP 0074-1

L

Ladder Bracket Replacement	WP 0059-1
Landing	
Gear	
Legs Cleaning	WP 0020-1
Maintenance	WP 0095-1
Operation	WP 0095-1
Repair Procedures	WP 0095-1
Landing, Replacement	WP 0050-1
LED Taillights Replacement	WP 0027-1
Lights	
Blackout, Replacement	WP 0025-1
Clearance, Replacement	WP 0026-1
LED, Taillight Replacement	WP 0027-1
List	
Abbreviations/Acronyms	WP 0001-3
Additional Authorization List (AAL)	WP 0084-1
Basic Issue Items (BII)	WP 0083-1
Expendable and Durable Items	WP 0085-1
Location and Description of Major Components	WP 0002-2
Lubrication Instructions	WP 0067-1

INDEX - CONTINUED

<u>Subject</u>	<u>WP Sequence No.-Page No.</u>
M	
M871A2R Equipment Data	WP 0002-7
M871R and M871A1R Equipment Data	WP 0002-6
M871R, M871A1R, M871A2R Equipment Data	WP 0002-8
Maintenance Allocation Chart (MAC)	
Introduction	WP 0081-1
Tables	WP 0082-1
Maintenance Forms, Records, and Reports	WP 0001-1
Manifest Box Replacement	WP 0058-1
Metric Equivalents	WP 0087-1
Mud or Sand, Operation Under Unusual Conditions	WP 0006-2
N	
Nose Plate Replacement (M871A2R)	WP 0029-1
O	
Operation Under Unusual Conditions	
Extreme Cold	WP 0006-1
Extreme Heat	WP 0006-1
Fording	WP 0006-2
Mud or Sand	WP 0006-2
Rainy or Humid Conditions	WP 0006-1
Rocky Terrain	WP 0006-2
Salt Water Areas	WP 0006-2
Snow	WP 0006-2
Operation Under Usual Condition	
After Use	WP 0005-14
Operation	WP 0005-8
Preparation for Use	WP 0005-1
Slinging Procedures	WP 0005-16
Operator PMCS	
Introduction	WP 0013-1
Tables	WP 0014-1
Operator Troubleshooting	
Introduction	WP 0007-1
Procedures	WP 0009-1
Symptom Index	WP 0008-1
Organizational PMCS	
Introduction	WP 0015-1
Tables	WP 0016-1
Organizational Troubleshooting	
Introduction	WP 0010-1
Procedures	WP 0012-1
Symptom Index	WP 0011-1
OSHA Standard Multi-Single Piece Wheel	WP 0098-1
P	
Preparation for Storage or Shipment	
General Information	WP 0001-1
Organizational	WP 0066-1

INDEX - CONTINUED

Subject

WP Sequence No.-Page No.

P - Continued

Pro-Torq Spindle Nut WP 0108-1

R

Rainy or Humid Conditions, Operation Under Unusual Conditions WP 0006-1

Receptacle Converter Box

 M871A2R, Replacement WP 0029-1

 M871R and M871A1R, Replacement WP 0028-1

 Maintenance WP 0089-1

References WP 0080-1

Reflectors Replacement WP 0060-1

Repair Instructions WP 0023-4

Reporting Equipment Improvement Recommendations (EIRs) WP 0001-1

Retractable Twist Lock

 Maintenance (M871R and M871A1R) WP 0045-1

 Replacement (M871A2R) WP 0046-1

Rocky Terrain, Operation Under Unusual Conditions WP 0006-2

RPSTL

 Figure WP 0078-1

 Introduction WP 0077-1

 NSN and P/N Indexes WP 0079-1

S

Salt Water Areas, Operation Under Unusual Conditions WP 0006-2

Sealed Brake

 Disarming WP 0096-1

 Installation WP 0096-1

Semitrailer Series, Theory of Operation WP 0003-1

Service Brakes

 S-Camshaft Replacement WP 0031-1

 S-Camshafts and Shoes WP 0107-1

 Shoes and Lining Replacement WP 0032-1

Service Upon Receipt WP 0065-1

Side Stakes Replacement WP 0053-1

SKF Scotseal WP 0103-1

Slack Adjusters Maintenance, Automatic WP 0034-1

Sling Procedures, Operation Under Usual Condition WP 0005-16

Spare Tire

 Carrier Maintenance WP 0048-1

 Replacement WP 0022-1

Storage or Shipment, Preparation for WP 0001-1

Stowage Box

 Replacement WP 0057-1

 Side Panels Replacement WP 0070-1

Suspension

 Replacement

 M871A2R WP 0072-1

 M871R and M871A1R WP 0071-1

INDEX - CONTINUED

<u>Subject</u>	<u>WP Sequence No.-Page No.</u>
T	
Tagging Wires and Hoses	WP 0023-4
Technical Information for LED and filament Bulb Lighting	WP 0093-1
Theory of Operation	WP 0003-1
Thread Pattern	WP 0088-1
Tiedown Rings Maintenance	WP 0047-1
Tire	
10 Tips	WP 0094-1
Repair	WP 0076-1
Replacement	WP 0021-1
Torque Limits	WP 0068-1
Transportability	WP 0001-2
Troubleshooting	
Brake Drums	WP 0101-1
Hubs	WP 0099-1
Spring Parking Brake	WP 0102-1
Wheel Problems	WP 0100-1
Twist Lock	
Maintenance, Retractable (M871R and M871A1R)	WP 0045-1
Replacement, Retractable (M871A2R)	WP 0046-1
U	
Upper Coupler Connections	WP 0091-1
W	
Warranty	WP 0001-2
Wheel	
Assembly Replacement	WP 0021-1
Assembly Replacement, Spare Tire	WP 0022-1
Chocks Repair	WP 0049-1
Wire Connectors Repair	WP 0024-1
Wiring Harnesses Replacement	WP 0030-1
Work Safety	WP 0023-2

RECOMMENDED CHANGES TO PUBLICATIONS AND BLANK FORMS For use of this form, see AR 25-30; the proponent agency is OAASA						Use Part II (<i>reverse</i>) for Repair Parts and Special Tool Lists (RPSTL) and Supply Catalogs/Supply Manuals (SC/SM).	DATE 1 July 2009
TO: (<i>Forward to proponent of publication or form</i>) (<i>Include ZIP Code</i>) AMSTA-LC-LMPP/TECH PUBS, TACOM-RI 1 Rock Island Arsenal Rock Island, IL 61299-7630						FROM: (<i>Activity and location</i>) (<i>Include ZIP Code</i>)	
PART I - ALL PUBLICATIONS (EXCEPT RPSTL AND SC/SM) AND BLANK FORMS							
PUBLICATION/FORM NUMBER TM 9-2330-335-14&P						DATE XX XXX XX	TITLE Field and Sustainment Maintenance Manual for Semitrailer, Tactical, Breakbulk/ Container Transporter 22 ½ Ton, RESET
ITEM	PAGE	PARA-	LINE	FIGURE NO.	TABLE	RECOMMENDED CHANGES AND REASON	
	0017 00-2					Part number supplied for item 2 is incorrect.	
TYPED NAME, GRADE OR TITLE						TELEPHONE EXCHANGE/AUTOVON, PLUS EXTENSION	
						SIGNATURE	

SAMPLE

TO: (Forward direct to addressee listed in publication)
 AMSTA-LC-LMPP/TECH PUBS, TACOM-RI
 1 Rock Island Arsenal
 Rock Island, IL 61299-7630

FROM: (Activity and location) (Include ZIP Code)

DATE

PART II - REPAIR PARTS AND SPECIAL TOOL LISTS AND SUPPLY CATALOGS/SUPPLY MANUALS

PUBLICATION NUMBER
 TM 9-2330-335-14&P

DATE
 XX XXX XX

TITLE Field and Sustainment Maintenance Manual
 for Semitrailer, Tactical, Breakbulk/
 Container Transporter 22 ½ Ton, RESET

PAGE NO.	COLM NO.	LINE NO.	NATIONAL STOCK NUMBER	REFERENCE NO.	FIGURE NO.	ITEM NO.	TOTAL NO. OF MAJOR ITEMS SUPPORTED	RECOMMENDED ACTION
SAMPLE								

PART III - REMARKS (Use this space for remarks, or suggestions for improvement of publications and drawings. Additional sheets may be used if space is needed.)

(This area is intentionally left blank for user input.)

TYPED NAME, GRADE OR TITLE

TELEPHONE EXCHANGE/AUTOVON, PLUS EXTENSION

SIGNATURE

RECOMMENDED CHANGES TO PUBLICATIONS AND BLANK FORMS For use of this form, see AR 25-30; the proponent agency is OAASA						Use Part II (<i>reverse</i>) for Repair Parts and Special Tool Lists (RPSTL) and Supply Catalogs/Supply Manuals (SC/SM).	DATE
TO: (<i>Forward to proponent of publication or form</i>) (<i>Include ZIP Code</i>) AMSTA-LC-LMPP/TECH PUBS, TACOM-RI 1 Rock Island Arsenal Rock Island, IL 61299-7630						FROM: (<i>Activity and location</i>) (<i>Include ZIP Code</i>)	
PART I - ALL PUBLICATIONS (EXCEPT RPSTL AND SC/SM) AND BLANK FORMS							
PUBLICATION/FORM NUMBER TM 9-2330-335-14&P						DATE XX XXX XX	TITLE Field and Sustainment Maintenance Manual for Semitrailer, Tactical, Breakbulk/ Container Transporter 22 ½ Ton, RESET
ITEM	PAGE	PARA-	LINE	FIGURE NO.	TABLE	RECOMMENDED CHANGES AND REASON	
TYPED NAME, GRADE OR TITLE					TELEPHONE EXCHANGE/AUTOVON, PLUS EXTENSION		SIGNATURE

TO: <i>(Forward direct to addressee listed in publication)</i> AMSTA-LC-LMPP/TECH PUBS, TACOM-RI 1 Rock Island Arsenal Rock Island, IL 61299-7630	FROM: <i>(Activity and location) (Include ZIP Code)</i>	DATE
---	--	-------------

PART II - REPAIR PARTS AND SPECIAL TOOL LISTS AND SUPPLY CATALOGS/SUPPLY MANUALS

PUBLICATION NUMBER TM 9-2330-335-14&P	DATE XX XXX XX	TITLE Field and Sustainment Maintenance Manual for Semitrailer, Tactical, Breakbulk/ Container Transporter 22 ½ Ton, RESET
---	--------------------------	---

PAGE NO.	COLM NO.	LINE NO.	NATIONAL STOCK NUMBER	REFERENCE NO.	FIGURE NO.	ITEM NO.	TOTAL NO. OF MAJOR ITEMS SUPPORTED	RECOMMENDED ACTION

PART III - REMARKS *(Any general remarks or recommendations, or suggestions for improvement of publications and blank forms. Additional blank sheets may be used if more space is needed.)*

TYPED NAME, GRADE OR TITLE	TELEPHONE EXCHANGE/AUTOVON, PLUS EXTENSION	SIGNATURE
----------------------------	--	-----------

RECOMMENDED CHANGES TO PUBLICATIONS AND BLANK FORMS For use of this form, see AR 25-30; the proponent agency is OAASA						Use Part II (<i>reverse</i>) for Repair Parts and Special Tool Lists (RPSTL) and Supply Catalogs/Supply Manuals (SC/SM).	DATE
TO: (<i>Forward to proponent of publication or form</i>) (<i>Include ZIP Code</i>) AMSTA-LC-LMPP/TECH PUBS, TACOM-RI 1 Rock Island Arsenal Rock Island, IL 61299-7630						FROM: (<i>Activity and location</i>) (<i>Include ZIP Code</i>)	
PART I - ALL PUBLICATIONS (EXCEPT RPSTL AND SC/SM) AND BLANK FORMS							
PUBLICATION/FORM NUMBER TM 9-2330-335-14&P						DATE XX XXX XX	TITLE Field and Sustainment Maintenance Manual for Semitrailer, Tactical, Breakbulk/Container Transporter 22 ½ Ton, RESET
ITEM	PAGE	PARA-	LINE	FIGURE NO.	TABLE	RECOMMENDED CHANGES AND REASON	
TYPED NAME, GRADE OR TITLE					TELEPHONE EXCHANGE/AUTOVON, PLUS EXTENSION		SIGNATURE

TO: <i>(Forward direct to addressee listed in publication)</i> AMSTA-LC-LMPP/TECH PUBS, TACOM-RI 1 Rock Island Arsenal Rock Island, IL 61299-7630	FROM: <i>(Activity and location) (Include ZIP Code)</i>	DATE
---	--	-------------

PART II - REPAIR PARTS AND SPECIAL TOOL LISTS AND SUPPLY CATALOGS/SUPPLY MANUALS

PUBLICATION NUMBER TM 9-2330-335-14&P	DATE XX XXX XX	TITLE Field and Sustainment Maintenance Manual for Semitrailer, Tactical, Breakbulk/ Container Transporter 22 ½ Ton, RESET
---	--------------------------	---

PAGE NO.	COLM NO.	LINE NO.	NATIONAL STOCK NUMBER	REFERENCE NO.	FIGURE NO.	ITEM NO.	TOTAL NO. OF MAJOR ITEMS SUPPORTED	RECOMMENDED ACTION

PART III - REMARKS *(Any general remarks or recommendations, or suggestions for improvement of publications and blank forms. Additional blank sheets may be used if more space is needed.)*

TYPED NAME, GRADE OR TITLE	TELEPHONE EXCHANGE/AUTOVON, PLUS EXTENSION	SIGNATURE
----------------------------	--	-----------

RECOMMENDED CHANGES TO PUBLICATIONS AND BLANK FORMS For use of this form, see AR 25-30; the proponent agency is OAASA						Use Part II (<i>reverse</i>) for Repair Parts and Special Tool Lists (RPSTL) and Supply Catalogs/Supply Manuals (SC/SM).	DATE
TO: (<i>Forward to proponent of publication or form</i>) (<i>Include ZIP Code</i>) AMSTA-LC-LMPP/TECH PUBS, TACOM-RI 1 Rock Island Arsenal Rock Island, IL 61299-7630						FROM: (<i>Activity and location</i>) (<i>Include ZIP Code</i>)	
PART I - ALL PUBLICATIONS (EXCEPT RPSTL AND SC/SM) AND BLANK FORMS							
PUBLICATION/FORM NUMBER TM 9-2330-335-14&P						DATE XX XXX XX	TITLE Field and Sustainment Maintenance Manual for Semitrailer, Tactical, Breakbulk/Container Transporter 22 ½ Ton, RESET
ITEM	PAGE	PARA-	LINE	FIGURE NO.	TABLE	RECOMMENDED CHANGES AND REASON	
TYPED NAME, GRADE OR TITLE					TELEPHONE EXCHANGE/AUTOVON, PLUS EXTENSION		SIGNATURE

TO: <i>(Forward direct to addressee listed in publication)</i> AMSTA-LC-LMPP/TECH PUBS, TACOM-RI 1 Rock Island Arsenal Rock Island, IL 61299-7630	FROM: <i>(Activity and location) (Include ZIP Code)</i>	DATE
---	--	-------------

PART II - REPAIR PARTS AND SPECIAL TOOL LISTS AND SUPPLY CATALOGS/SUPPLY MANUALS

PUBLICATION NUMBER TM 9-2330-335-14&P	DATE XX XXX XX	TITLE Field and Sustainment Maintenance Manual for Semitrailer, Tactical, Breakbulk/ Container Transporter 22 ½ Ton, RESET
---	--------------------------	---

PAGE NO.	COLM NO.	LINE NO.	NATIONAL STOCK NUMBER	REFERENCE NO.	FIGURE NO.	ITEM NO.	TOTAL NO. OF MAJOR ITEMS SUPPORTED	RECOMMENDED ACTION

PART III - REMARKS *(Any general remarks or recommendations, or suggestions for improvement of publications and blank forms. Additional blank sheets may be used if more space is needed.)*

TYPED NAME, GRADE OR TITLE	TELEPHONE EXCHANGE/AUTOVON, PLUS EXTENSION	SIGNATURE
----------------------------	--	-----------

By Order of the Secretary of the Army:

GEORGE W. CASEY, JR.
General, United States Army
Chief of Staff

Official:

JOYCE E. MORROW
Administrative Assistant to the
Secretary of the Army
0825904

DISTRIBUTION: To be distributed in accordance with the initial distribution requirements for IDN: 391055, requirements for TM 9-2330-335-14&P.

THE METRIC SYSTEM AND EQUIVALENTS

<p>Linear Measure</p> <p>1 Centimeter = 10 Millimeters = 0.01 Meters = 0.3937 Inches 1 Meter = 100 Centimeters = 1000 Millimeters = 39.37 Inches 1 Kilometer = 1000 Meters = 0.621 Miles</p> <p>Weights</p> <p>1 Gram = 0.001 Kilograms = 1000 Milligrams = 0.035 Ounces 1 Kilogram = 1000 Grams = 2.2 Pounds 1 Metric Ton = 1000 Kilograms = 1 Megagram = 1.1 Short Tons</p> <p>Liquid Measure</p> <p>1 Milliliter = 0.001 Liters = 0.0338 Fluid Ounces 1 Liter = 1000 Milliliters = 33.82 Fluid Ounces</p>	<p>Square Measure</p> <p>1 Sq Centimeter = 100 Sq Millimeters = 0.155 Sq Inches 1 Sq Meter = 10,000 Sq Centimeters = 10.76 Sq Feet 1 Sq Kilometer = 1,000,000 Sq Meters = 0.386 Sq Miles</p> <p>Cubic Measure</p> <p>1 Cu Centimeter = 1,000 Cu Millimeters = 0.06 Cu Inches 1 Cu Meter = 1,000,000 Cu Centimeters = 35.31 Cu Feet</p> <p>Temperature</p> <p>$5/9 (^{\circ}\text{F} - 32) = ^{\circ}\text{C}$ 212° Fahrenheit is equivalent to 100° Celsius 90° Fahrenheit is equivalent to 32.2° Celsius 32° Fahrenheit is equivalent to 0° Celsius $9/5 \text{ C}^{\circ} + 32 = \text{F}^{\circ}$</p>
--	--

APPROXIMATE CONVERSION FACTORS

To Change	To	Multiply By
Inches	Centimeters	2.540
Feet	Meters	0.305
Yards	Meters	0.914
Miles	Kilometers	1.609
Sq Inches	Sq Centimeters	6.451
Sq Feet	Sq Meters	0.093
Sq Yards	Sq Meters	0.836
Sq Miles	Sq Kilometers	2.590
Acres	Sq Hectometers	0.405
Cubic Feet	Cubic Meters	0.028
Cubic Yards	Cubic Meters	0.765
Fluid Ounces	Milliliters	29.573
Pints	Liters	0.473
Quarts	Liters	0.946
Gallons	Liters	3.785
Ounces	Grams	28.349
Pounds	Kilograms	0.454
Short Tons	Metric Tons	0.907
Pound-Feet	Newton-Meters	1.356
Pounds per Sq Inch	Kilopascals	6.895
Miles per Gallon	Kilometers per Liter	0.425
Miles per Hour	Kilometers per Hour	1.609

To Change	To	Multiply By
Centimeters	Inches	0.394
Meters	Feet	3.280
Meters	Yards	1.094
Kilometers	Miles	0.621
Sq Centimeters	Sq Inches	0.155
Sq Meters	Sq Feet	10.764
Sq Meters	Sq Yards	1.196
Sq Kilometers	Sq Miles	0.386
Sq Hectometers	Acres	2.471
Cubic Meters	Cubic Feet	35.315
Cubic Meters	Cubic Yards	1.308
Milliliters	Fluid Ounces	0.034
Liters	Pints	2.113
Liters	Quarts	1.057
Liters	Gallons	0.264
Grams	Ounces	0.035
Kilograms	Pounds	2.205
Metric Tons	Short Tons	1.102
Newton-Meters	Pound-Feet	0.738
Kilopascals	Pounds per Sq Inch	0.145
Kilometers per Liter	Miles per Gallon	2.354
Kilometers per Hour	Miles per Hour	0.621

